



FINAL REPORT

**Foundation Investigation
Highway 417 Overpass Structures at Bronson Avenue
Rapid Bridge Replacement
Sites: 3-60/1 & 3-60/2
Ottawa, Ontario**

G.W.P. 4173-15-00

W.P. 4073-13-01 & 4074-13-01

Submitted to:

WSP Canada Group Limited

2611 Queensview Drive, Suite 300
Ottawa, Ontario
K2B 8K2

Submitted by:

Golder Associates Ltd.

1931 Robertson Road, Ottawa, Ontario, K2H 5B7, Canada

GEOCREs No.: 31G5-306

Latitude: 45.404900

Longitude: -75.701935

1655214-1130

June 2019



Distribution List

4 copies - Ministry of Transportation Ontario

1 e-copy - WSP Canada Group Limited

1 e-copy - Golder

Table of Contents

PART A – FOUNDATION INVESTIGATION

1.0 INTRODUCTION	1
2.0 SITE DESCRIPTION AND GEOLOGY	1
2.1 Site Description	1
2.2 Regional Geology	2
3.0 INVESTIGATION PROCEDURES	2
3.1 Current Investigations (2017 and 2018)	2
3.2 Previous Investigations (1961)	6
4.0 DESCRIPTION OF SUBSURFACE CONDITIONS	7
4.1 General	7
4.2 Overburden	7
4.3 Highway 417 Approach Embankments	7
4.3.1 Surface Cover / Surficial Materials	7
4.3.2 Fill	8
4.3.3 Glacial Till	8
4.4 Bronson Avenue	8
4.4.1 Surface Cover / Surficial Materials	8
4.4.2 Fill	8
4.4.3 Glacial Till	9
4.5 Staging Area	9
4.5.1 Surface Cover / Surficial Materials	9
4.5.2 Fill	9
4.5.3 Silty Sand	9
4.5.4 Silt	10
4.5.5 Glacial Till	10
4.6 Concrete Footings	10
4.7 Bedrock	10

4.8	Groundwater Conditions	12
4.9	Steel Corrosion and Sulphate Attack, Chemical Analysis	12
5.0	CLOSURE	13
TABLES EMBEDDED WITHIN REPORT		
	Table 1: Summary of Corehole/Drillhole Locations	4
	Table 2: Summary of Borehole Locations	5
	Table 3: Summary of Bedrock Surface Depths and Elevations	11
	Table 4: Summary of Groundwater Conditions	12
	Table 5: Steel Corrosion and Sulphate Attack, Chemical Analysis.....	12

DRAWINGS

Drawings 1 to 5 - Highway 417 Overpass Structures at Bronson Avenue, Sites 3-60/1 & 2, Borehole Locations and Soil Strata

APPENDICES

APPENDIX A

Record of Boreholes, Current Investigation

Lists of Abbreviations and Symbols
 Lithological and Geotechnical Rock Description Terminology
 Record of Coreholes/Drillholes 17-C01 to 17-C24
 Record of Boreholes 17-131 to 17-134
 Record of Boreholes 18-1301 to 18-1311
 Bedrock Core Photographs, Figures A1 to A32
 Table A1 - Concrete Core Condition Assessment

APPENDIX B

Laboratory Test Results, Current Investigation

Figure B1 – Grain Size Distribution Test Results – Sand and Gravel (Fill)
 Figure B2 – Grain Size Distribution Test Results – Sand (Fill)
 Figure B3 – Grain Size Distribution Test Results – Sand (Fill)
 Figure B4 – Grain Size Distribution Test Results – Silt (Fill)
 Figure B5 – Grain Size Distribution Test Results – Sand (Fill)
 Figure B6 – Grain Size Distribution Test Results – Silty Sand
 Figure B7 – Grain Size Distribution Test Results – Silt
 Figure B8 – Grain Size Distribution Test Results – Glacial Till
 Figure B9 – Summary of Laboratory Compressive Strength Unconfined Compression Tests

APPENDIX C

**Drawing D5001-1 – Bridge N° 18 at Bronson Avenue, General Arrangement
Previous Investigations, GEOCREC 31G05-043 (1961)**

Record of Boreholes 1 to 6

Boring Plan and Soil Stratigraphy

Laboratory Test Results

APPENDIX D

Basic Chemical Analysis Results

Eurofins Report Numbers 1717833 and 1901731

APPENDIX E

MASW Test Results and Report

Sites 3-56/1 and 3-56/2 Highway 417 Overpass at Rochester Street

APPENDIX F

Site Photographs

PART A

Foundation Investigation
Highway 417 Overpass Structures at Bronson Avenue
Rapid Bridge Replacement
Sites: 3-60/1 & 3-60/2
Ottawa, Ontario

1.0 INTRODUCTION

Golder Associates Ltd. (Golder) has been retained by WSP Canada Group Limited (WSP) on behalf of the Ministry of Transportation, Ontario (MTO) to carry out foundation investigations associated with the detailed design of numerous bridge replacements, overhead signs, noise barrier walls, temporary roadway protection systems, replacement of storm sewers (including trenchless crossings) and a high fill embankment on Highway 417 between Island Park Drive and Kent Street in Ottawa, Ontario (Assignment number 4016-E-0001).

This report presents the results of the foundation investigation carried out for the rapid bridge replacement (RBR) of the Highway 417 eastbound (Site 3-60/1) and westbound (Site 3-60/2) overpass structures at Bronson Avenue, (G.W.P. 4173-15-00, W.P. 4073-13-01 and W.P. 4074-13-01). The replacement of the structures is to be carried out in accordance with the current version of the Canadian Highway Bridge Design Code, S6-14 (CHBDC).

The terms of reference and scope of work for the foundation investigation are outlined in the MTO's Request for Proposal, dated April 2016, and subsequent addenda. Golder's scope of work for foundation engineering services associated with the Highway 417 Overpasses at Bronson Avenue is contained in Table 17.8.3 of WSP's Technical Proposal for this assignment dated June 28, 2016. The work has been carried out in accordance with Golder's Quality Control Plan for foundation engineering services for the project dated August 29, 2016.

2.0 SITE DESCRIPTION AND GEOLOGY

2.1 Site Description

Sites 3-60/1 and 3-60/2 are located at approximate Station 27+800 on Highway 417, approximately 870 m east of the O-Train Trillium Line, within the City of Ottawa. The location of the overpass structures is shown on the Key Plan on Drawings 1 through 5. Site photographs showing the general conditions at the site are presented in Appendix F.

At this location, Highway 417 is a divided highway with four travel lanes in each direction separated by a concrete barrier wall.

Each of the existing structures is a single-span concrete rigid frame bridge that is supported on shallow foundations founded directly on bedrock. Information provided in the RFP indicates that the structures were built in 1962. The structures have a clear span of 23.8 m measured perpendicular to the abutments and are separated from each other by a longitudinal joint. The average overall deck width of each structure, measured perpendicular to the centerline of the highway, is approximately 19.0 m. Each abutment has two retaining walls located along the north and south sides of the highway embankment for retaining the embankment fill. Noise barrier walls are located only along the north side of the highway west of the west abutment, no noise barriers are located on the structures.

The existing approach embankments are about 6 to 7 m in height relative to the elevation of Bronson Avenue, with side slopes oriented at approximately 2 horizontal to 1 vertical (2H:1V). Based on visual observation at the time of the site investigation, the existing embankment slopes appeared to be performing satisfactorily.

2.2 Regional Geology

As delineated in *The Physiography of Southern Ontario*¹, this section of Highway 417 lies within the minor physiographic region known as the Ottawa Valley Clay Plain, which lies within the major physiographic region of the Ottawa-St. Lawrence Lowland.

The Ottawa Valley Clay Plain region is characterized by relatively thick deposits of sensitive marine clay, silt and silty clay that were deposited within the former Champlain Sea basin. These deposits, known as the Champlain Sea clay or Leda clay, overlie relatively thin, commonly reworked glacial till and glaciofluvial deposits, that in turn overlie bedrock².

This region is underlain by a series of sedimentary rocks, consisting of sandstones, dolostones, limestones and shales that are, in turn, underlain at depth by igneous and metamorphic bedrock of the Precambrian Shield. Regional bedrock mapping indicates that the bedrock at this site is primarily limestone of the Verulam Formation.³ The limestone is described as interbedded bioclastic, sublithographic to fine crystalline, very thin to medium bedded, with shale interbeds up to 8 centimetres thick.

The structures are located between two known faults striking southeast to northeast. The more prominent fault, the Gloucester fault crosses Highway 417 at the approximate location of Preston Street.⁴ The second fault crosses Highway 417 some 400 m to the east of Bronson. Bedding which is normally sub-horizontal often dips steeply adjacent to and within fault zones.

The site falls within the Western Québec (WQ) seismic zone according to the Geological Survey of Canada. The WQ zone constitutes a large area which encompasses the urban areas of Montreal, Ottawa-Hull and Cornwall. Within the WQ zone recent seismic activity has been concentrated in two subzones; one along the Ottawa River and another more active subzone along the Montreal-Maniwaki axis. The two major earthquakes that have recently occurred in the WQ zone are the 1935 Témiscaming event, which had a magnitude (i.e., a measure of the intensity of the earthquake) of 6.2, and the 1944 Cornwall-Massena event, which had a magnitude of 5.6.

3.0 INVESTIGATION PROCEDURES

3.1 Current Investigations (2017 and 2018)

The field work for the 2017 investigation was carried out between July 19 and August 8, 2017 and included advancing a total of 24 coreholes, designated 17-C01 to 17-C24, and four boreholes, designated 17-131 to 17-134, that were located along Bronson Avenue. A supplemental investigation was carried out between October 3 and 17, 2018 and November 7 and 22, 2018, that included advancing eleven additional boreholes located within the approach and highway embankments, designated Boreholes 18-1301 to 18-1308. The NAD83 CSRS CBNv6-2010.0 MTM Zone 9 locations and ground surface elevations of the test holes are shown on Drawings 1 to 5. Tables 1 and 2 further outline the location of the testholes with respect to the existing structures.

¹ Chapman, L. J. and Putnam, D. F., 1984. *The Physiography of Southern Ontario*, Ontario Geological Survey. Special Volume 2, Third Edition. Accompanied by Map P.2715, Scale 1:600,000. Ontario Ministry of Natural Resources.

² Belanger, J.R. "Urban Geology of Canada's National Capital Area", in *Urban Geology of Canadian Cities*, Geological Association of Canada Special Paper 42, Ed. P.F. Karrow and O.L. White, 1998.

³ Williams, D.A. Rae, A.M., and Wolf, R.R. 1984: Paleozoic Geology of the Ottawa Area, Southern Ontario, Ontario Geological Survey, Map P.2716. Geological Series-Preliminary Map, scale 1:50,000. Geology 1982.

⁴ MacDonald, G. and Harrison, J.E. 1976 : Generalized Bedrock Geology, Ottawa-Hull, Ontario and Quebec, Geological Survey of Canada, Map 1508A, scale 1:125,000. Geology 1967.

Coreholes 17-C01 17-C24 (12 per abutment) were drilled at approximately 3 m spacings along Bronson Avenue through the existing sidewalks and subsequently hydro-excavated to expose the top of the existing footings. Eight of the coreholes (four per abutment) were further advanced into the underlying bedrock to form Drillholes 17-C01D, 17-C04D, 17-C09D, 17-C11D, 17-C13D, 17-C17D, 17-C19D, and 17-C24D. Drillhole 17-C09D was drilled on an incline due to the proximity of the corehole location to the adjacent abutment. The angle of inclination is indicated on the Record of Drillhole and is orientated relative to the horizontal, with an azimuth perpendicular to the abutments.

Boreholes 17-131 to 17-134 were located on Bronson Avenue to the north and south of the existing abutments, while Boreholes 18-1301 to 18-1304 were advanced through the existing Highway 417 embankments. Boreholes 18-1305 to 18-1308 were located within the highway approach embankments behind the existing abutments. Boreholes 18-1309 to 18-1311 were advanced at the proposed staging area located to the southeast of the existing eastbound structure.

The coreholes/drillholes were advanced using a combination of portable rotary drilling and hydro-vac equipment. Boreholes 18-1301 to 18-1304 were advanced using only portable rotary drilling equipment employing a third weight hammer lifted manually and dropped from the SPT height. Where a third weight hammer was used, the N values presented on the Record of Boreholes are “uncorrected” and should be interpreted in consideration of their reduced penetration energy. The remaining boreholes were advanced using a combination of truck-mounted drilling and hydro-excavation equipment. All drilling equipment was supplied and operated by CCC Geotechnical & Environmental Drilling Ltd. of Ottawa, Ontario. Traffic control required to close either the driving lanes of the Highway or Bronson Avenue while carrying out field operations was provided by Beacon Lite Ltd. of Ottawa Ontario.

Soil samples from the portable drilling equipment were obtained in continuous vertical sampling increments of about 0.6 m using a 50 mm outside diameter split spoon sampler in general accordance with the Standard Penetration Test (SPT) procedure (ASTM D1586). Grab samples of the overburden were recovered from within the hydro-excavations carried out at the coreholes/drillholes and at Borehole 17-131. Soil samples from boreholes advanced with truck-mounted drilling equipment were obtained at vertical intervals of about 0.76 m also in accordance with ASTM D1586. Bedrock core samples were obtained using NQ sized equipment.

Monitoring wells were installed in Boreholes 17-134 and 18-1305 to observe the groundwater level across the site. The monitoring wells consist of 32 mm outside diameter PVC tubing with a 1.5 m long screen.

The groundwater levels were measured in the monitoring wells on August 23, 2017 (17-134) and December 6, 2018 (18-1305). The monitoring wells were decommissioned after taking the final water level measurement, according to O.Reg 903 by a licenced well installer.

Where cored, the holes advanced through the existing footings and bedrock were grouted following completion of work. The coreholes/drillholes were then backfilled with granular material above the existing footing level to the underside of the existing sidewalk, then capped with concrete. The boreholes were backfilled with bentonite within the bedrock and bentonite mixed with soil cuttings within the overburden and capped with either concrete sidewalk patch or asphaltic concrete cold patch, depending on the surrounding surface cover. The boreholes were backfilled in general accordance with the intent of Ontario MOE Regulation 903, as amended. The site conditions were restored following completion of the field work.

The field work was supervised on a full-time basis by members of Golder’s staff who located the testholes in the field, directed the drilling, sampling, and in-situ testing operations, logged the testholes and examined and cared for the samples. The soil and bedrock samples were identified in the field, placed in labelled containers, and

transported to Golder's laboratory in Ottawa for further examination and testing. Index and classification tests consisting of water content determinations and grain size distribution analyses were carried out on selected soil samples at Golder's Ottawa laboratory. Unconfined compressive strength testing was carried out on six samples of the bedrock core at Golder's Mississauga laboratory. The laboratory tests were carried out to MTO and/or ASTM Standards, as appropriate.

A total of five soil samples were submitted to Eurofins Environment Testing for chemical analysis related to potential corrosion of exposed buried steel and potential sulphate attack on buried concrete elements (corrosion and sulphate attack).

In addition to the borehole investigations at the current sites, shear wave velocity profiling was completed at the nearby Highway 417 Overpass Structures at Rochester Street (Sites 3-56/1 and 3-56/2), located approximately 550 m west of Bronson Avenue. Due to the close proximity and similar nature of the surficial and bedrock geology of the sites, the profiles developed for the Sites 3-56/1 and 3-56/2 are considered relevant to the current structures.

The shear wave velocity profiling was carried out on the Highway 417 eastbound E-N/S off-ramp of the Highway 417 / Rochester Street Interchange, just west of Rochester Street employing the Multichannel Analysis of Surface Waves (MASW) technique. The MASW profiling was carried out on October 18, 2017, by personnel from Golder's Mississauga and Ottawa offices. A series of low frequency (4.5 Hz) geophones were laid out at 2 m intervals. A 9.9 kg sledge hammer and 34 kg weight drop were used as the seismic source. The source locations were offset at various distances beyond the end and collinear with the geophone array.

The testhole locations and elevations were surveyed by Golder using a Trimble R8 GPS unit. The testhole locations, including northing and easting coordinates, ground surface and top of existing abutment footing elevations referenced to the NAD83 CSRS CBNv6-2010.0 MTM Zone 9 geodetic datum, and drilled/cored depths are summarized in Tables 1 and 2.

Table 1: Summary of Corehole/Drillhole Locations

Corehole / Drillhole	Location	NAD83 CSRS CBNv6-2010.0 MTM Zone 9		Ground Surface Elevation (m)	Top of Existing Footing Elevation (m)	Corehole / Drillhole Depth (m)
		Northing (m)	Easting (m)			
17-C01/D	Sidewalk along Bronson Avenue at east abutment	5029769.3	367278.0	69.5	68.5	3.2
17-C02		5029766.5	367279.1	69.4	68.4	1.0
17-C03		5029763.6	367280.3	69.4	68.4	1.1
17-C04/D		5029761.0	367281.5	69.5	68.5	2.8
17-C05		5029757.8	367282.8	69.5	69.0 ¹	0.5
17-C06		5029754.8	367284.0	69.5	69.0 ¹	0.6
17-C07		5029751.7	367285.3	69.7	69.2 ¹	0.5
17-C08		5029748.6	367286.6	69.7	68.9 ¹	0.8
17-C09/D		5029745.6	367287.8	69.8	68.7	5.7
17-C10		5029742.5	367289.2	69.8	68.6	1.2
17-C11/D		5029739.3	367290.6	69.9	68.9	3.7
17-C12		5029736.4	367291.7	70.0	69.0	1.0

Corehole / Drillhole	Location	NAD83 CSRS CBNv6-2010.0 MTM Zone 9		Ground Surface Elevation (m)	Top of Existing Footing Elevation (m)	Corehole / Drillhole Depth (m)
		Northing (m)	Easting (m)			
17-C13/D	Sidewalk along Bronson Avenue west abutment	5029728.0	367270.1	70.0	68.8	3.1
17-C14		5029730.7	367268.9	69.9	69.5 ¹	0.4
17-C15		5029733.8	367267.7	69.8	69.4 ¹	0.4
17-C16		5029736.4	367266.5	69.8	69.4 ¹	0.4
17-C17/D		5029739.4	367265.3	69.7	68.6	3.0
17-C18		5029742.5	367264.0	69.6	68.4	1.2
17-C19/D		5029745.3	367262.7	69.6	68.4	2.5
17-C20		5029748.4	367261.6	69.6	68.5 ²	1.1
17-C21		5029751.0	367260.5	69.5	69.1 ¹	0.4
17-C22		5029753.9	367259.2	69.5	68.5	1.0
17-C23		5029756.8	367258.0	69.5	68.5 ²	1.0
17-C24/D		5029759.8	367256.8	69.5	68.4	2.5

Notes: C = Corehole only

C/D = Combination Corehole and Drillhole

¹ Refusal to hydro-excavation on conduit

² Refusal to hydro-excavation on inferred wood formwork

Table 2: Summary of Borehole Locations

Borehole	Location	NAD83 CSRS CBNv6-2010.0 MTM Zone 9		Ground Surface Elevation (m)	Top of Existing Footing Elevation (m)	Borehole Depth (m)
		Northing (m)	Easting (m)			
17-131	Bronson Avenue Southwest of west abutment	5029723.5	367276.0	70.0	N/A	4.9
17-132	Bronson Avenue Southeast of east abutment	5029729.5	367290.4	70.1		5.3
17-133	Bronson Avenue Northwest of west abutment	5029764.9	367258.1	69.4		4.1
17-134	Bronson Avenue Northeast of east abutment	5029772.1	367272.0	69.3		5.8
18-1301	Highway 417 Embankment Northwest of west abutment	5029759.9	367250.0	71.6	69.3	5.5
18-1302	Highway 417 Embankment Southwest of west abutment	5029724.1	367265.0	72.3	69.5	6.5
18-1303	Bronson Avenue Northeast of east abutment	5029772.9	367281.5	69.5	68.4	4.5
18-1304	Highway 417 Embankment Southeast of east abutment	5029737.0	367296.7	69.7	69.0	3.8

Borehole	Location	NAD83 CSRS CBNv6-2010.0 MTM Zone 9		Ground Surface Elevation (m)	Top of Existing Footing Elevation (m)	Borehole Depth (m)
		Northing (m)	Easting (m)			
18-1305	Highway 417 Westbound West of west abutment	5029743.1	367253.1	75.7	N/A	7.9
18-1306	Highway 417 Eastbound West of west abutment	5029727.0	367259.4	76.0		6.6
18-1307	Highway 417 Westbound East of east abutment	5029771.2	367290.2	75.5		7.7
18-1308	Highway 417 Eastbound East of east abutment	5029754.4	367294.6	75.8		8.3
18-1309	Staging Area Southeast of eastbound structure	5029734.2	367312.9	70.1		3.2
18-1310	Staging Area Southeast of eastbound structure	5029707.8	367353	71.9		6.3
18-1311	Staging Area Southeast of eastbound structure	5029774.9	367417.2	70.1		7.3

3.2 Previous Investigations (1961)

A previous investigation was carried out for the design of the existing structures in 1961 by H.Q Golder and Associates Ltd. The subsurface information and results of the original investigation are contained in the report titled:

- *Site Investigation, Proposed Queensway-Bronson Overpass, Bridge No. 18, Ottawa, Ontario*, dated August 1961, (Report No. 6105, GEOCREs No. 31G05-043).

As part of the current assignment, previously collected subsurface information pertinent to the site was reviewed and compiled.

A total of six boreholes (each with an adjacent dynamic penetration test - DPT) and one additional DPT were advanced at the site as part of the original investigation along the then proposed bridge alignment over Bronson Avenue. The Record of Borehole sheets and laboratory testing results from the previous investigation are provided for reference in Appendix C. The approximate borehole locations and ground surface elevations are shown on Drawings 1 to 2.

The locations of the previous boreholes should be considered approximate since the locations were referenced to an imperial borehole location plan rather than metric MTM coordinates. Further, the boreholes from the previous investigation were advanced prior to construction of the bridge and the ground surface conditions shown may not be representative of the post-construction subsurface conditions, particularly with respect to the composition and thickness of overburden and fill. It is also unknown if the surface of the bedrock as encountered in the 1961 investigation was altered during construction of the overpass structure. Therefore, the stratigraphy encountered in the 1961 boreholes was not included in the stratigraphic profiles shown on Drawings 1 to 2.

4.0 DESCRIPTION OF SUBSURFACE CONDITIONS

4.1 General

The subsurface soil, bedrock and groundwater conditions encountered in the boreholes and the results of in-situ testing from the current investigation are given on the Record of Borehole, Corehole, and Drillhole sheets presented in Appendix A. The results of the laboratory testing carried out during the current investigation are presented on the Record of Borehole sheets as well as on Figures B1 to B8 in Appendix B. The borehole locations and the interpreted stratigraphic profile projected along each abutment and staging area are provided on Drawings 1 to 5.

Photographs of the core recovered from the concrete footings and underlying bedrock are shown on Figures A1 to A32 provided in Appendix A. An assessment of the condition of the Portland Cement Concrete (PCC) footing cores is provided in Table A1 of Appendix A. The results of basic chemical analysis completed on select soil samples are provided in Appendix D.

The MASW test results and report from Sites 3-56/1 and 3-56/2 are presented in Appendix E and include the calculated shear wave velocity profile measured from the field testing and a graphical representation of the shear wave velocity profile with depth for those sites.

The stratigraphic boundaries shown on the testhole sheets and on the interpreted stratigraphic sections from Drawings 1 to 5, are inferred from observations of drilling progress and noncontinuous sampling and therefore, represent transitions between soil types rather than exact planes of geological change. The subsoil conditions will vary between and beyond the borehole locations.

4.2 Overburden

In general, the subsurface conditions at the testhole locations advanced along Bronson Avenue consist of PCC sidewalk at surface, overlying granular fill overlying PCC footing and/or limestone bedrock. At the embankment, approach and staging area boreholes the subsurface conditions consisted of asphalt/concrete or topsoil surface cover, overlying fill materials, overlying native silt sand and glacial till all underlain by limestone bedrock. Due to the age of the structures, it is possible that remnants of temporary works abandoned after construction of the existing structure may be buried in the fill.

The groundwater level was measured at the site at depths ranging from 1.5 to 7.5 m, corresponding to Elevations 65.8 and 68.3 m.

A more detailed description of the overburden soil deposits, concrete footings, bedrock geology and groundwater conditions encountered during the field investigation is provided in the following sections.

4.3 Highway 417 Approach Embankments

4.3.1 Surface Cover / Surficial Materials

A layer of topsoil was encountered at the ground surface of the embankment at Boreholes 18-1301, 18-1302 and 18-1304. The thickness of the topsoil at the borehole locations ranges from 100 to 400 mm.

Boreholes 18-1305 to 18-1308 were advanced through the Highway 417 pavement structure. The thickness of the asphaltic concrete at the borehole locations ranges from 300 mm in Boreholes 18-1305 and 18-1308 to 100 mm in Boreholes 18-1307 and 18-1306.

Portland cement concrete was encountered below the asphaltic concrete in Boreholes 18-1306 and 18-1307 and is 300 and 500 mm in thickness, respectively.

4.3.2 Fill

Pavement Structure – Sand and Gravel to Sand

A fill layer consisting predominantly of sand and gravel with varying amounts of silt was encountered below the concrete layers in approach Boreholes 18-1305 to 18-1308. The top of this layer was encountered at elevations ranging from 74.9 to 75.6 m. The thickness of the fill ranges from 1.6 to 2.8 m. The SPT N values ranged from 35 to 85, indicating a dense to very dense condition.

The moisture content of the samples tested ranged from 3 to 6 percent. The results of a grain size analysis test carried out on a single sample of this material are provided on Figure B1 in Appendix B.

Sand

Fill consisting predominantly of sand with varying amounts of gravel and silt was encountered below the pavement structure in Boreholes 18-1301 to 18-1308. The top of this layer was encountered at elevations ranging from 69.4 to 73.9 m. The thickness of the layer ranges from 0.6 to 5.4 m. The SPT N values ranged from 3 to greater than 100, indicating a very loose to very dense condition, but more typically compact to dense.

The moisture content of the samples tested ranged from 4 to 10 percent. The results of grain size analysis tests carried out on seven samples of this material are provided on Figures B2 and B3 in Appendix B.

4.3.3 Glacial Till

A non-cohesive glacial till deposit consisting of a heterogeneous mixture of sand, gravel and silt was encountered beneath the fill materials in Boreholes 18-1305 to 18-1308. The till is classified as a silty sand some gravel and clay to gravelly silty sand. The top of this deposit was encountered at elevations ranging from 68.2 to 70.7 m. The thickness of the till ranges from 0.4 to 1.4 m, as inferred from auger refusal. The SPT N values ranged from 6 to greater than 100, indicating a loose to very dense condition, but more typically compact.

The moisture content of the samples tested ranged from 5 to 18 percent. The results of grain size analysis tests carried out on two samples of this material are provided on Figure B8 in Appendix B.

4.4 Bronson Avenue

4.4.1 Surface Cover / Surficial Materials

A Portland cement concrete sidewalk was encountered at the ground surface of all coreholes/drillholes advanced along Bronson Avenue. The thickness of the concrete ranges from 100 to 200 mm at the test hole locations.

Boreholes 17-131 to 17-134 were advanced through the Bronson Avenue pavement structure. The thickness of the asphaltic concrete at the borehole locations was 100 mm.

Portland cement concrete was encountered below the asphalt layer in Boreholes 17-131, to 17-134. The thickness of this layer ranged from 200 to 300 mm.

4.4.2 Fill

Gravelly Sand, Sand and Gravel, Sand

A fill layer consisting predominantly of sand with varying amounts of gravel and silt was encountered below the Portland cement concrete at the Bronson Avenue testhole locations. The top of this layer was encountered at elevations ranging from 69.3 to 69.9 m. The thickness of the layer ranges from 0.7 to 1.4 m. The SPT N values

ranged from 15 to greater than 100, indicating a compact to very dense condition, but more typically compact. As noted in Table 1 in Section 3.1, refusal to hydro-excavation was encountered on conduits or wood formwork in Coreholes 17-C05, 17-C06, 17-C20, 17 C21, and 17-C23.

The moisture content of the samples tested ranged from 4 to 11 percent. The results of grain size analysis tests carried out on two samples of this material are provided on Figures B1 and B2 in Appendix B.

4.4.3 Glacial Till

A non-cohesive glacial till deposit consisting of a heterogeneous mixture of sand, gravel and silt was encountered beneath the fill materials in Borehole 17-132. The till is classified as gravelly silty sand. The top of this layer was encountered at elevation 69.1 m. The thickness of this layer is 0.9 m, as inferred from auger refusal. The SPT N values ranged from 93 to greater than 100, indicating a very dense condition.

4.5 Staging Area

4.5.1 Surface Cover / Surficial Materials

Asphaltic concrete, 50 mm in thickness, was encountered at the ground surface at Boreholes 18-1310 and 18-1311.

4.5.2 Fill

Gravelly Sand, Sand and Gravel, Sand

A fill layer consisting predominantly of sand with varying amounts of gravel and silt was encountered below the asphaltic concrete at Boreholes 18-1310 and 18-1311 and at the ground surface at Borehole 18-1309. The top of the fill was encountered at elevations ranging from 70.0 to 71.8 m. The thickness of the layer ranges from 1.4 to 3.1 m. The SPT N values ranged from 6 to 33, indicating a loose to dense condition, but typically compact.

The moisture content of the samples tested ranged from 5 to 15 percent. The results of a grain size analysis test carried out on a single sample of this material from Borehole 18-1310 are provided on Figure B5.

Silt

Fill consisting predominantly of silt, with varying amounts of sand, was encountered below the sand fill at Boreholes 18-1309 and 18-1310. The top of this layer was encountered at elevations 68.2 and 68.6 m and the thickness of the silt fill layer is 1.2 m. The SPT N values ranged from 1 to 3, indicating a very loose condition.

The moisture content of the samples tested was 18 and 19 percent. The results of grain size analysis tests carried out on two samples of this material are provided on Figure B4 in Appendix B.

It should be noted that strong hydrocarbon odour was noted in the fill materials in the staging area boreholes. Samples of the possibly impacted materials were collected for environmental testing by WSP. Further details with regards to the material handling, reuse and/or disposal are provided in WSP's 2018 Phase II ESA and Earth 2019 Management Plan Reports, which are provided under separate cover.

4.5.3 Silty Sand

A silty sand layer was encountered below the fill at Borehole 18-1311. The top of this layer was encountered at elevation 68.6 m and the thickness of this layer is 3.8 m. The SPT N values ranged from 4 to 15, indicating a loose to compact condition.

The moisture content of the single sample tested was 13 percent. The results of a grain size analysis test carried out on a single sample of this material are provided on Figure B6 in Appendix B.

4.5.4 Silt

A silt deposit was encountered below the sand layer in Borehole 18-1311. The top of this layer was encountered at elevation 64.8 m and the thickness of the layer is 1.0 m. The SPT N value was 11, indicating a compact condition.

The moisture content of the sample tested was 21 percent. The results of a grain size analysis test carried out on a single sample of this material are provided on Figure B7 in Appendix B.

4.5.5 Glacial Till

A non-cohesive glacial till deposit consisting of a heterogeneous mixture of sand, gravel and silt was encountered beneath the fill materials in Boreholes 18-1309 to 18-1310 and below the silt layer in Borehole 18-1311. The till is classified as a silty sand and gravel to silty sand some gravel. The top of this deposit was encountered at elevations ranging from 63.9 to 67.4 m. The thickness of the till ranges from 0.6 to 1.4 m, as inferred from auger refusal. The SPT N values ranged from 10 to greater than 100, indicating a compact to very dense condition, but more typically compact to dense.

The moisture content of the sample tested 8 percent. The results of grain size analysis tests carried out on a single sample of the till are provided on Figure B8 in Appendix B.

4.6 Concrete Footings

The existing concrete footings were encountered in coreholes/drillholes 17-C01 to 17-C24 and embankment Boreholes 18-1301 to 18-1304. The top of the concrete footing was encountered at elevations ranging from 68.3 to 69.5 m. The thickness of the footings ranges from 0.8 to 3.9 m, as indicated by coring through the existing footing to the underlying bedrock. Tables 1 and 2 in Section 3.1 provide the top of footing elevation at each of the testhole locations. An assessment of the condition of the Portland Cement Concrete (PCC) footing cores is provided in Table A1 of Appendix A.

4.7 Bedrock

The overburden materials and concrete footings are underlain by limestone bedrock with shale partings and interbeds. Bedrock geology mapping indicates that the limestone bedrock is of the Verulam Formation.

Bedrock was proven by coring using NQ sized equipment in Boreholes 17-131 to 17-134 and 18-1301 to 18-1304, and Drillholes 17-C01, 17-C04, 17-C09, 17-C11, 17-C13, 17-C17, 17-C19, and 17-C24. Photographs of the bedrock core are provided in Appendix A. Bedrock was also proven by coring using BX sized coring equipment in Boreholes 1 to 6 during the 1961 investigation.

Table 3 summarizes the depth to, and the elevation of the bedrock surface as encountered at the testhole locations from the current and previous investigations.

Table 3: Summary of Bedrock Surface Depths and Elevations

Drillhole / Borehole	Drillhole / Borehole Location	Existing Ground Surface Elevation (m)	Depth to the Bedrock Surface (m)	Bedrock Surface Elevation (m)
17-C01D	Sidewalk along Bronson Avenue at east abutment	69.5	2.5	67.0
17-C04D		69.5	2.0	67.5
17-C09D		69.8	5.1	64.8
17-C11D		69.9	3.1	66.8
17-C13D	Sidewalk along Bronson Avenue at west abutment	70.0	2.3	67.7
17-C17D		69.7	1.9	67.8
17-C19D		69.6	1.8	67.8
17-C24D		69.5	1.8	67.7
17-131	Bronson Avenue Southwest of west abutment	70.0	1.8	68.2
17-132	Bronson Avenue Southeast of east abutment	70.1	1.9	68.1
17-133	Bronson Avenue Northwest of west abutment	69.4	1.1	68.3
17-134	Bronson Avenue Northeast of east abutment	69.3	1.9	67.4
18-1301	Highway 417 Embankment Northwest of west abutment	71.6	3.7	67.9
18-1302	Highway 417 Embankment Southwest of west abutment	72.3	4.4	67.9
18-1303	Bronson Avenue Northeast of east abutment	69.5	2.5	67.0
18-1304	Highway 417 Embankment Southeast of east abutment	69.7	1.8	67.9
1	East Approach of Bronson Avenue	68.5	4.9	63.6
2	East approach	68.6	2.6	66.0
3	East approach	68.8	5.4	63.5
4	East approach	68.6	2.5	66.1
5	East abutment	69.4	1.0	68.4
6	West abutment	71.1	2.0	69.1

The bedrock encountered was slightly weathered to fresh and thinly to medium bedded. Thin shale interbeds were also present in the bedrock core. Rock Quality Designation (RQD) values measured on recovered bedrock core samples typically ranged from about 0 to 100 percent, but more generally ranging from about 70 to 100 percent indicating good to excellent quality rock.

Results of unconfined compressive strength (UCS) testing carried out on six bedrock core samples are presented on Figure B9 provided in Appendix B. The samples tested had UCS values ranging from 54 and 93 MPa, indicating a strong bedrock.

4.8 Groundwater Conditions

Monitoring wells were installed in Boreholes 17-134, 18-1305 and 18-1310 to monitor the groundwater level across the site.

Table 4 summarizes the depths to, and the elevations of the groundwater level measured in the monitoring wells installed at the site.

Table 4: Summary of Groundwater Conditions

Borehole	Location	Screened Interval	Depth to the Groundwater Level (m)	Groundwater Elevation (m)	Date of Reading
17-134	Bronson Avenue Northeast of east abutment	Bedrock	1.5	67.8	August 23, 2017
18-1305	Highway 417 Westbound West of west abutment	Fill Glacial till	7.4	68.3	December 6, 2018
18-1310	Staging Area Southeast of eastbound structure	Silt and till	4.3	65.8	December 6, 2018

It is expected that the groundwater level will be subject to fluctuations both seasonally and as a result of precipitation events.

4.9 Steel Corrosion and Sulphate Attack, Chemical Analysis

A total of five soil samples were submitted to Eurofins Environment Testing for chemical analysis related to potential corrosion of exposed buried steel and potential sulphate attack on buried concrete elements (corrosion and sulphate attack). The test results are provided in Appendix D and are summarized in Table 5.



Table 5: Steel Corrosion and Sulphate Attack, Chemical Analysis

Borehole	Sample	Sample Depth (m)	Sample Type	Chloride (%)	Sulphate (%)	Electrical Conductivity (mS/cm)	pH	Resistivity (ohm-cm)
17-132	SS2	0.9 – 1.4	Till	0.050	0.06	1.26	8.2	794
18-1301	SS4	1.8 – 2.4	Fill	0.007	0.04	0.10	8.4	10,000
18-1304	SS2	0.6 – 0.7	Fill	< 0.002	0.06	<0.05	8.8	25,000
18-1309	SS5	3.0 – 3.2	Sand	0.006	0.06	0.32	8.0	3,120
18-1311	SS9	6.1 – 6.7	Till	0.005	0.03	0.12	7.8	8,330



5.0 CLOSURE

This report was prepared by Mr. Kenton Power, P.Eng. It was reviewed by Mr. Bill Cavers, P.Eng., a Senior geotechnical engineer and Associate of Golder. Mr. Fintan Heffernan, P.Eng. a Senior Consultant with Golder and the Designated MTO Foundations Contact for this project, carried out an independent quality control review of this report.

Golder Associates Ltd.



Kenton C. Power, P.Eng, M.A.Sc.
Geotechnical Engineer



William Cavers, P.Eng
Associate, Senior Geotechnical Engineer



Fintan J. Heffernan, P.Eng.
Designated MTO Foundations Contact

KCP/MC/FJH/mvrd

https://golderassociates.sharepoint.com/sites/18579g/foundations/6-reports/1130-bronson/final/1655214-1130-001-r-rev0-bronson_ave_bridge-06-2019_fir.docx

Golder and the G logo are trademarks of Golder Associates Corporation

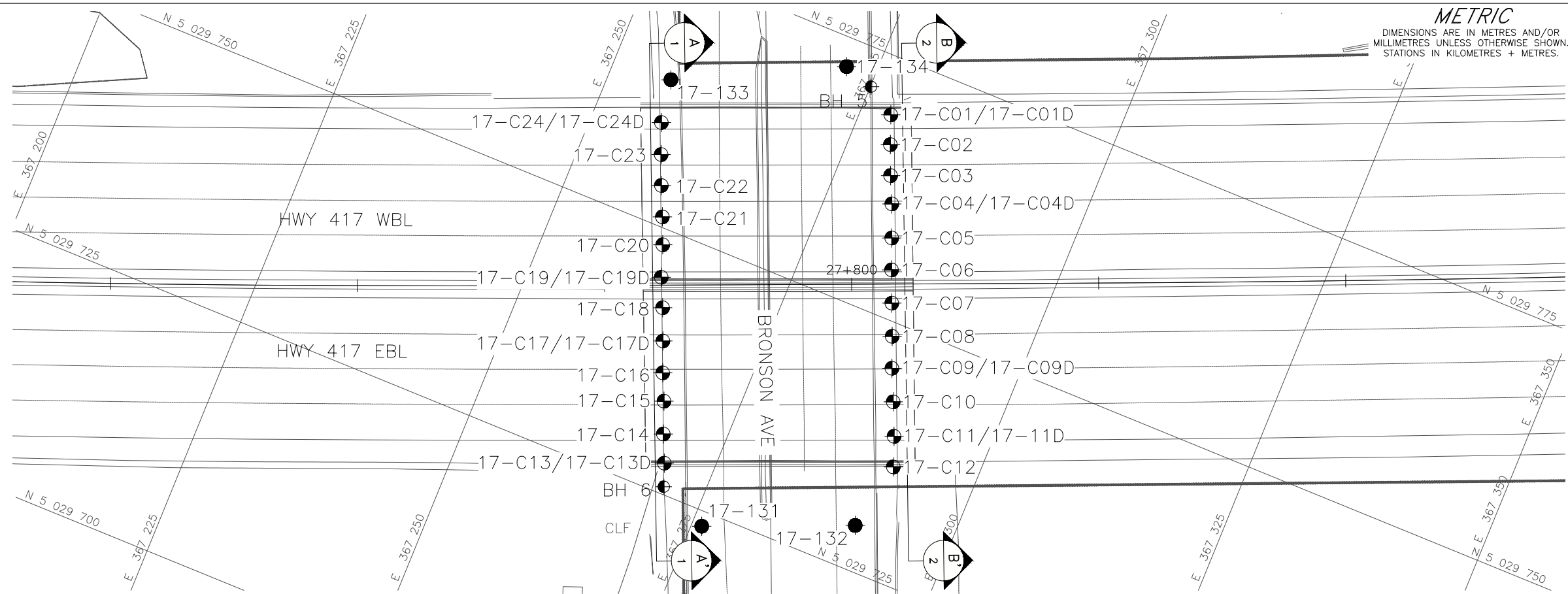

METRIC
DIMENSIONS ARE IN METRES AND/OR MILLIMETRES UNLESS OTHERWISE SHOWN. STATIONS IN KILOMETRES + METRES.

CONT No. GWP No. 4173-15-00

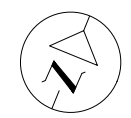

**HIGHWAY 417 OVERPASS
STRUCTURE AT BRONSON AVENUE**
BOREHOLE LOCATIONS AND SOIL STRATA
LAT. 45.404900 LONG. -75.701935

SHEET



KEY PLAN
SCALE
500 0 500 1000 m

LEGEND

- Borehole - Current Investigation
- ⊕ Corehole - Current Investigation
- ⊙ Borehole - Previous Investigation (Geocres No. 31G05-043)
- Inclined Borehole Orientation
- ⊥ Seal
- ⊥ Piezometer
- N Standard Penetration Test Value
- 16 Blows/0.3m unless otherwise stated (Std. Pen. Test, 475 j/blow)
- 100% Rock Quality Designation (RQD)

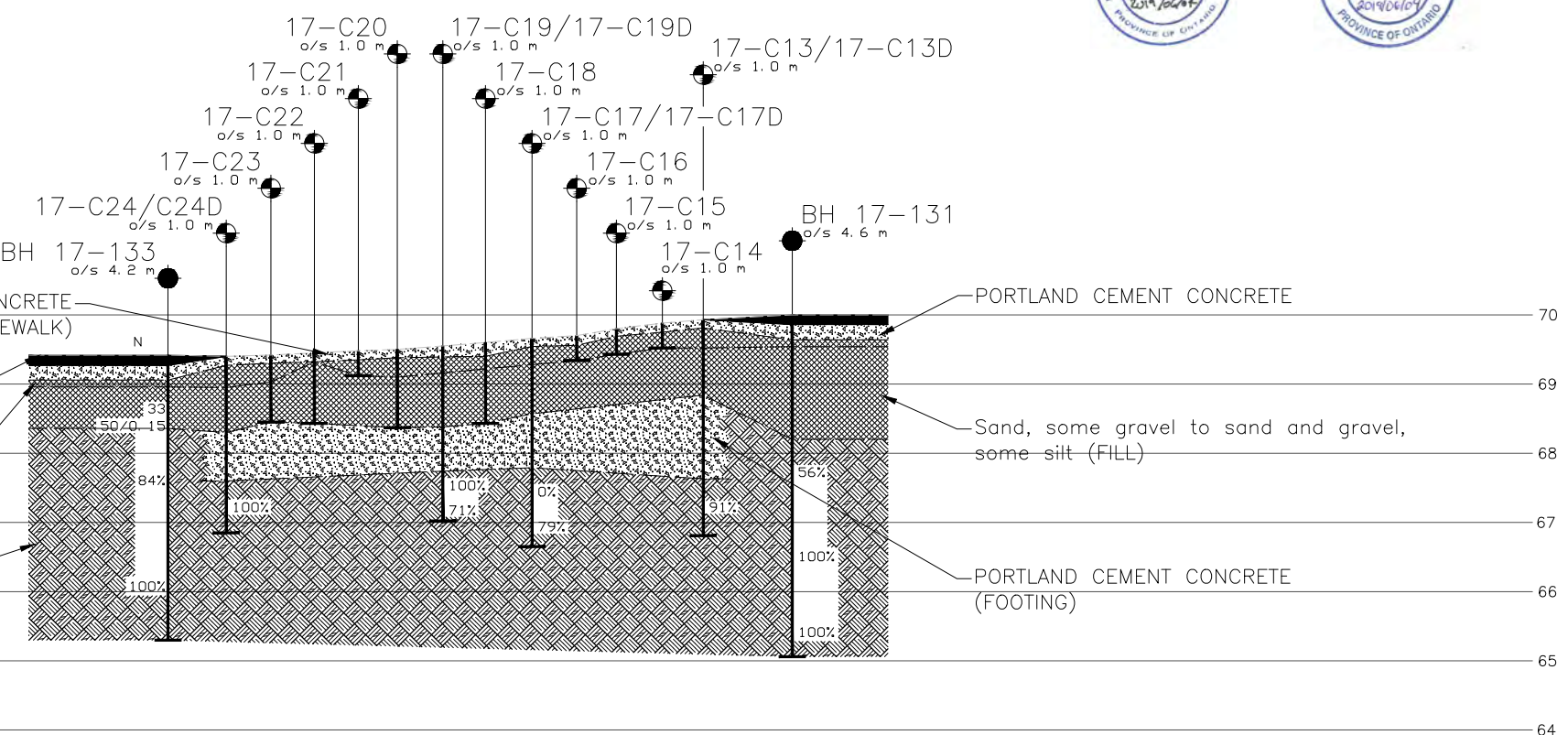

CROSS-SECTION A-A'

SCALE
5 0 5 10 m
1 0 1 2 m

NOTES

This drawing is for subsurface information only. The proposed structure details/works are shown for illustration purposes only and may not be consistent with the final design configuration as shown elsewhere in the Contracts Documents.

The boundaries between soil strata have been established only at borehole locations. Between boreholes the boundaries are assumed from geological evidence.

REFERENCE

Base plans provided in digital format by WSP Canada Group Limited, drawing file nos. MIDTOWN-XB1.dwg and 3416024-XA1-MEDIAN.dwg, received APR. 19, 2017.

BOREHOLE CO-ORDINATES NAD83 (CSRS)/MTM ZONE 9

No.	ELEVATION	NORTHING	EASTING
17-131	70.0	5029723.5	367276.0
17-132	70.1	5029729.5	367290.4
17-133	69.4	5029764.9	367258.1
17-134	69.3	5029772.1	367272.0
17-C01/C01D	69.5	5029769.3	367278.0
17-C02	69.5	5029766.5	367279.1
17-C03	69.5	5029763.6	367280.3
17-C04/C04D	69.5	5029761.0	367281.5
17-C05	69.5	5029757.8	367282.8
17-C06	69.5	5029754.8	367284.0
17-C07	69.6	5029751.7	367285.3
17-C08	69.7	5029748.6	367286.6
17-C09/C09D	69.8	5029745.6	367287.8
17-C10	69.8	5029742.5	367289.2
17-C11/C11D	69.9	5029739.3	367291.7
17-C12	69.9	5029736.4	367293.1
17-C13/C13D	69.9	5029728.0	367270.1
17-C14	69.9	5029730.7	367268.9
17-C15	69.8	5029733.8	367267.7
17-C16	69.7	5029736.4	367266.5
17-C17/C17D	69.7	5029739.4	367265.3
17-C18	69.6	5029742.5	367264.0
17-C19/C19D	69.6	5029745.3	367262.7
17-C20	69.5	5029748.4	367261.6
17-C21	69.5	5029751.0	367260.5
17-C22	69.5	5029753.9	367259.2
17-C23	69.4	5029756.8	367258.0
17-C24/C24D	69.4	5029759.8	367256.8
5	69.4	5029771.1	367275.1
6	71.1	5029725.8	367271.0

NO.	DATE	BY	REVISION

Geocres No. 31G5-306

HWY. 417	PROJECT NO. 1655214-1130	DIST. EASTERN
SUBM'D. KP	CHKD. KP	DATE: 2/28/2019
DRAWN: JM	CHKD. FJH	APPD. FJH
		SITE: 3-60/1&2
		DWG. 1

PLOT DATE: Apr 19, 2017
 FILENAME: K:\Active\Spatial\IM\MTD\ Hwy417\Rehab\WSP\1655214-1130-0001.dwg

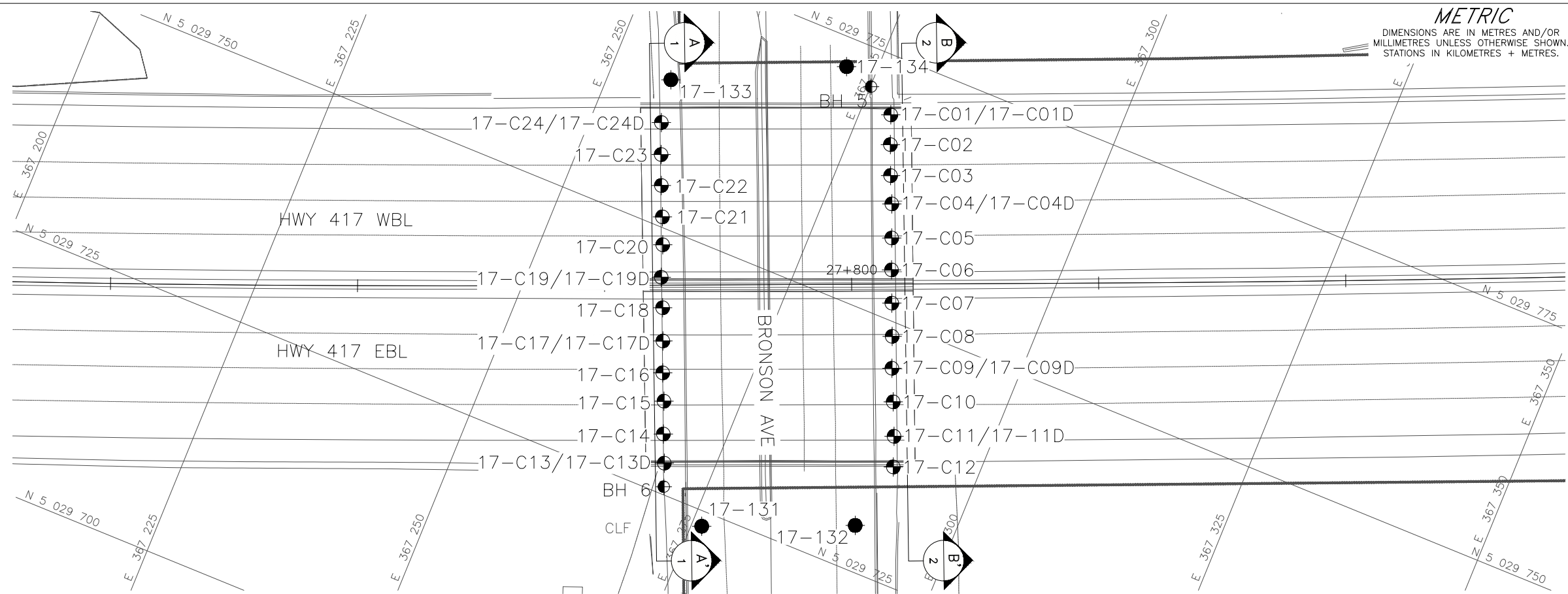

PLAN
SCALE
0 5 10 m

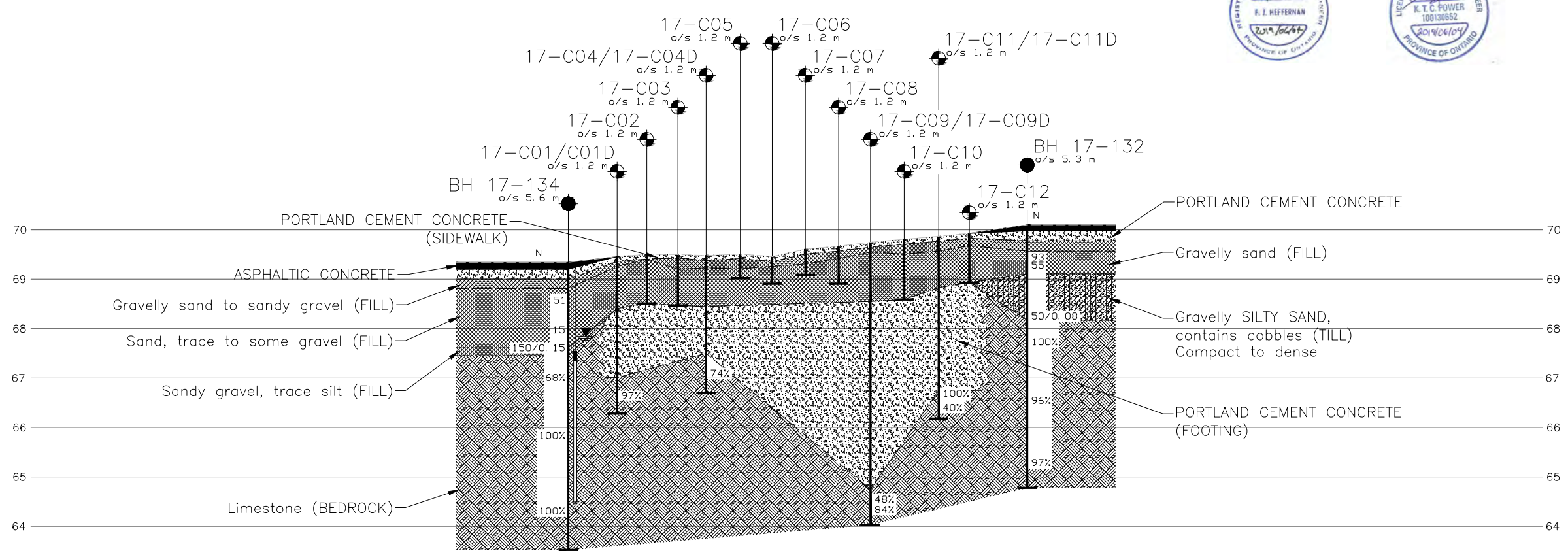

CROSS-SECTION B-B'
SCALE
0 5 10 m

NOTES
This drawing is for subsurface information only. The proposed structure details/works are shown for illustration purposes only and may not be consistent with the final design configuration as shown elsewhere in the Contracts Documents.
The boundaries between soil strata have been established only at borehole locations. Between boreholes the boundaries are assumed from geological evidence.

REFERENCE
Base plans provided in digital format by WSP Canada Group Limited, drawing file nos. MIDTOWN-XB1.dwg and 3416024-XA1-MEDIAN.dwg, received APR. 19, 2017.

METRIC
DIMENSIONS ARE IN METRES AND/OR MILLIMETRES UNLESS OTHERWISE SHOWN. STATIONS IN KILOMETRES + METRES.

CONT No. GWP No. 4173-15-00

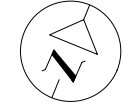

**HIGHWAY 417 OVERPASS
STRUCTURE AT BRONSON AVENUE**
BOREHOLE LOCATIONS AND SOIL STRATA
LAT. 45.404900 LONG. -75.701935

SHEET



KEY PLAN
SCALE
0 500 1000 m

- LEGEND**
- Borehole - Current Investigation
 - ⊕ Corehole - Current Investigation
 - ⊙ Borehole - Previous Investigation (Geocres No. 31G05-043)
 - Inclined Borehole Orientation
 - ⊥ Seal
 - ⊥ Piezometer
 - N Standard Penetration Test Value
 - 16 Blows/0.3m unless otherwise stated (Std. Pen. Test, 475 j/blow)
 - 100% Rock Quality Designation (RQD)
 - ≡ WL in piezometer, measured on AUGUST 23, 2017

BOREHOLE CO-ORDINATES NAD83 (CSRS)/MTM ZONE 9

No.	ELEVATION	NORTHING	EASTING
17-131	70.0	5029723.5	367276.0
17-132	70.1	5029729.5	367290.4
17-133	69.4	5029764.9	367258.1
17-134	69.3	5029772.1	367272.0
17-C01/C01D	69.5	5029769.3	367278.0
17-C02	69.5	5029766.5	367279.1
17-C03	69.5	5029763.6	367280.3
17-C04/C04D	69.5	5029761.0	367281.5
17-C05	69.5	5029757.8	367282.8
17-C06	69.5	5029754.8	367281.5
17-C07	69.6	5029751.7	367284.0
17-C08	69.7	5029748.6	367285.3
17-C09/C09D	69.8	5029745.6	367286.6
17-C10	69.8	5029742.5	367287.8
17-C11/C11D	69.9	5029739.3	367289.2
17-C12	69.9	5029736.4	367290.6
17-C13/C13D	69.9	5029728.0	367291.7
17-C14	69.9	5029730.7	367270.1
17-C15	69.8	5029733.8	367268.9
17-C16	69.7	5029736.4	367267.7
17-C17/C17D	69.7	5029739.4	367266.5
17-C18	69.6	5029742.5	367265.3
17-C19/C19D	69.6	5029745.3	367264.0
17-C20	69.5	5029748.4	367262.7
17-C21	69.5	5029751.0	367261.6
17-C22	69.5	5029753.9	367260.5
17-C23	69.4	5029756.8	367259.2
17-C24/C24D	69.4	5029759.8	367258.0
5	69.4	5029771.1	367256.8
6	71.1	5029725.8	367275.1

NO.	DATE	BY	REVISION

Geocres No. 31G5-306

HWY. 417	PROJECT NO. 1655214-1130	DIST. EASTERN
SUBM'D. KP	CHKD. KP	DATE: 2/28/2019
DRAWN: JM	CHKD. FJH	APPD. FJH
		SITE: 3-60/1&2
		DWG. 2

PLOT DATE: 2019-04-15
 FILENAME: K:\Active\Spatial\MTM\1655214_1130\1655214_1130-BC-0002.dwg

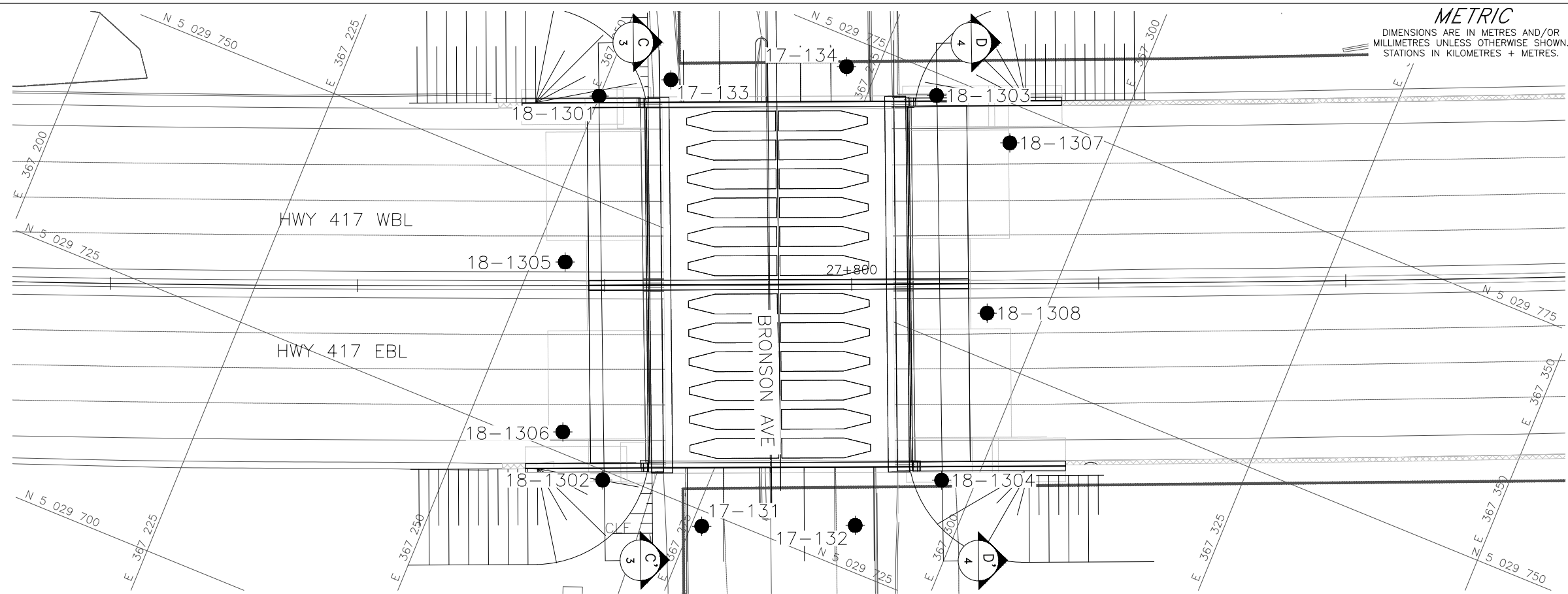

PLAN
SCALE
5 0 5 10 m



METRIC
DIMENSIONS ARE IN METRES AND/OR MILLIMETRES UNLESS OTHERWISE SHOWN. STATIONS IN KILOMETRES + METRES.

CONT No.
GWP No. 4173-15-00

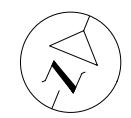

**HIGHWAY 417 OVERPASS
STRUCTURE AT BRONSON AVENUE**
BOREHOLE LOCATIONS AND SOIL STRATA
LAT. 45.404900 LONG. -75.701935

SHEET



KEY PLAN
SCALE
500 0 500 1000 m

LEGEND

- Borehole - Current Investigation
- ⊥ Seal
- ⊏ Piezometer
- N Standard Penetration Test Value
- 16 Blows/0.3m unless otherwise stated (Std. Pen. Test, 475 j/blow)
- 100% Rock Quality Designation (RQD)
- ≡ WL in piezometer, measured on December 6, 2018
- ≡ WL upon completion of drilling

BOREHOLE CO-ORDINATES NAD83 (CSRS)/MTM ZONE 9

No.	ELEVATION	NORTHING	EASTING
17-131	70.0	5029723.5	367276.0
17-132	70.1	5029729.5	367290.4
17-133	69.4	5029764.2	367256.1
17-134	69.3	5029772.1	367272.0
18-1301	71.6	5029759.9	367250.0
18-1302	72.3	5029724.1	367265.0
18-1303	69.5	5029772.9	367281.5
18-1304	69.7	5029737.0	367296.7
18-1305	75.7	5029743.1	367253.1
18-1306	76.0	5029727.0	367259.4
18-1307	75.5	5029771.2	367290.2
18-1308	75.8	5029754.4	367294.6

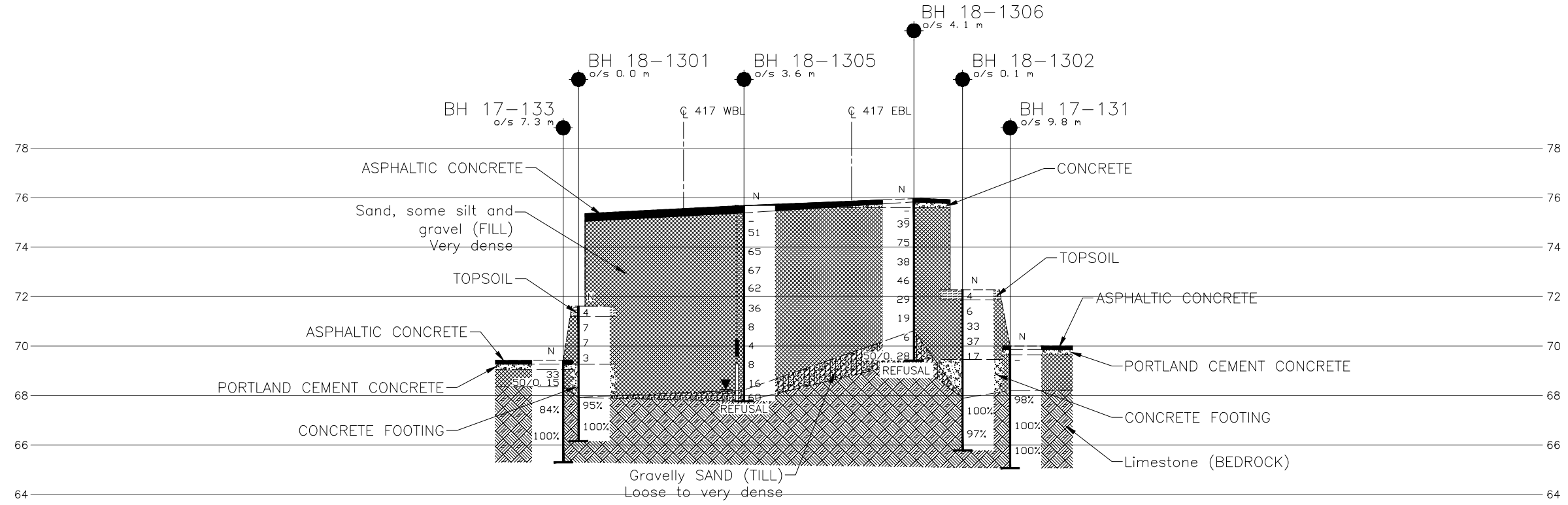

CROSS-SECTION C-C'

SCALE
5 0 5 10 m
2 0 2 4 m

REFERENCE

Base plans provided in digital format by WSP Canada Group Limited, drawing file no. S3416024-307-001GA-2.dwg, received MAY 17, 2019.

NOTES

This drawing is for subsurface information only. The proposed structure details/works are shown for illustration purposes only and may not be consistent with the final design configuration as shown elsewhere in the Contracts Documents.
The boundaries between soil strata have been established only at borehole locations. Between boreholes the boundaries are assumed from geological evidence.

NO.	DATE	BY	REVISION

Geocres No. 31G5-306		PROJECT NO. 1655214-1130		DIST. EASTERN	
HWY. 417	CHKD. KP	DATE: 2/28/2019	SITE: 3-60/1&2		
SUBM'D. KP	CHKD. FJH	APPD. FJH	DWG. 3		

PLOT DATE: Jun 6, 2019
 FILENAME: N:\Active\Spatial\MTM\417\Rehab\Working\99_PROJ\1655214_LTD_1130\Phase1\130_Bronson\1655214-1130-BC-0003.dwg

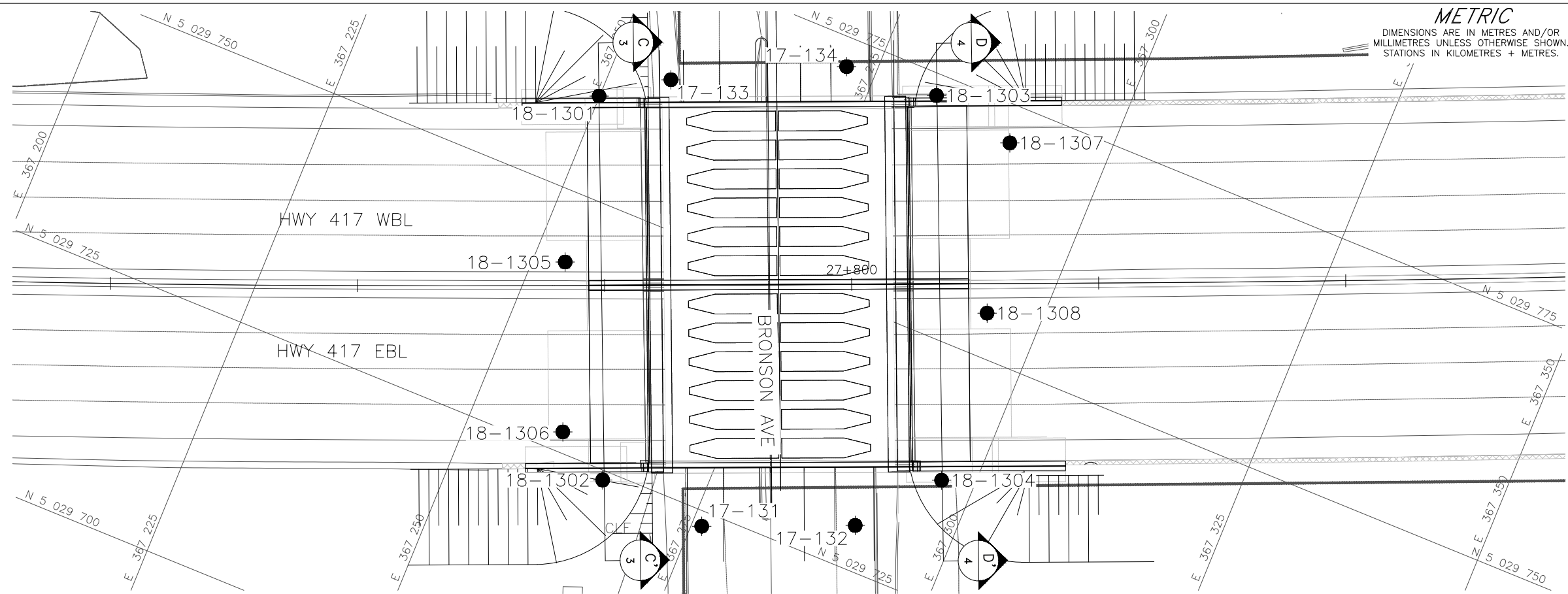

PLAN
SCALE
5 0 5 10 m



CONT No. GWP No. 4173-15-00

HIGHWAY 417 OVERPASS
STRUCTURE AT BRONSON AVENUE
BOREHOLE LOCATIONS AND SOIL STRATA
LAT. 45.404900 LONG. -75.701935

SHEET



KEY PLAN
SCALE
500 0 500 1000 m

- LEGEND
- Borehole - Current Investigation
 - ⊥ Seal
 - ⊏ Piezometer
 - N Standard Penetration Test Value
 - 16 Blows/0.3m unless otherwise stated (Std. Pen. Test, 475 j/blow)
 - 100% Rock Quality Designation (RQD)
 - ▽ WL in piezometer, measured on August 23, 2017
 - ▽ WL upon completion of drilling

BOREHOLE CO-ORDINATES NAD83 (CSRS)/MTM ZONE 9

No.	ELEVATION	NORTHING	EASTING
17-131	70.0	5029723.5	367276.0
17-132	70.1	5029729.5	367290.4
17-133	69.4	5029764.2	367256.1
17-134	69.3	5029772.1	367272.0
18-1301	71.6	5029759.9	367250.0
18-1302	72.3	5029724.1	367265.0
18-1303	69.5	5029772.9	367281.5
18-1304	69.7	5029737.0	367296.7
18-1305	75.7	5029743.1	367253.1
18-1306	76.0	5029727.0	367259.4
18-1307	75.5	5029771.2	367290.2
18-1308	75.8	5029754.4	367294.6

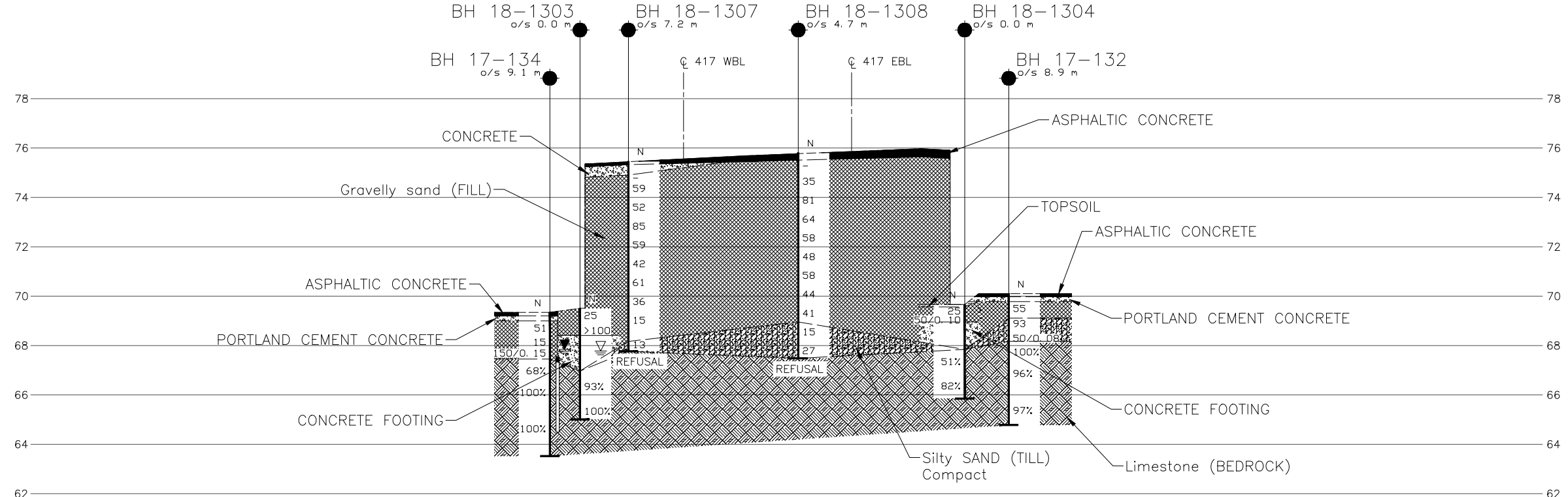

CROSS-SECTION D-D'

SCALE
5 0 5 10 m
2 0 2 4 m

REFERENCE
Base plans provided in digital format by WSP Canada Group Limited, drawing file no. S3416024-307-001GA-2.dwg, received MAY 7, 2019.

NOTES

This drawing is for subsurface information only. The proposed structure details/works are shown for illustration purposes only and may not be consistent with the final design configuration as shown elsewhere in the Contracts Documents.

The boundaries between soil strata have been established only at borehole locations. Between boreholes the boundaries are assumed from geological evidence.

NO.	DATE	BY	REVISION

Geocres No. 31G5-306

HWY. 417	PROJECT NO. 1655214-1130	DIST. EASTERN
SUBM'D. KP	CHKD. KP	DATE: 2/28/2019
DRAWN: JM	CHKD. FJH	APPD. FJH
		SITE: 3-60/1&2
		DWG. 4

PLOT DATE: Jun 5, 2019
 FILENAME: N:\Active\Spatial_LM\MTD\ Hwy417\Rehab\WSP\99_PROJ\1655214-LTD_Hwy417BridgeReplacement\00_PROD\Phase1130_Bronson\1655214-1130-60-0004.dwg

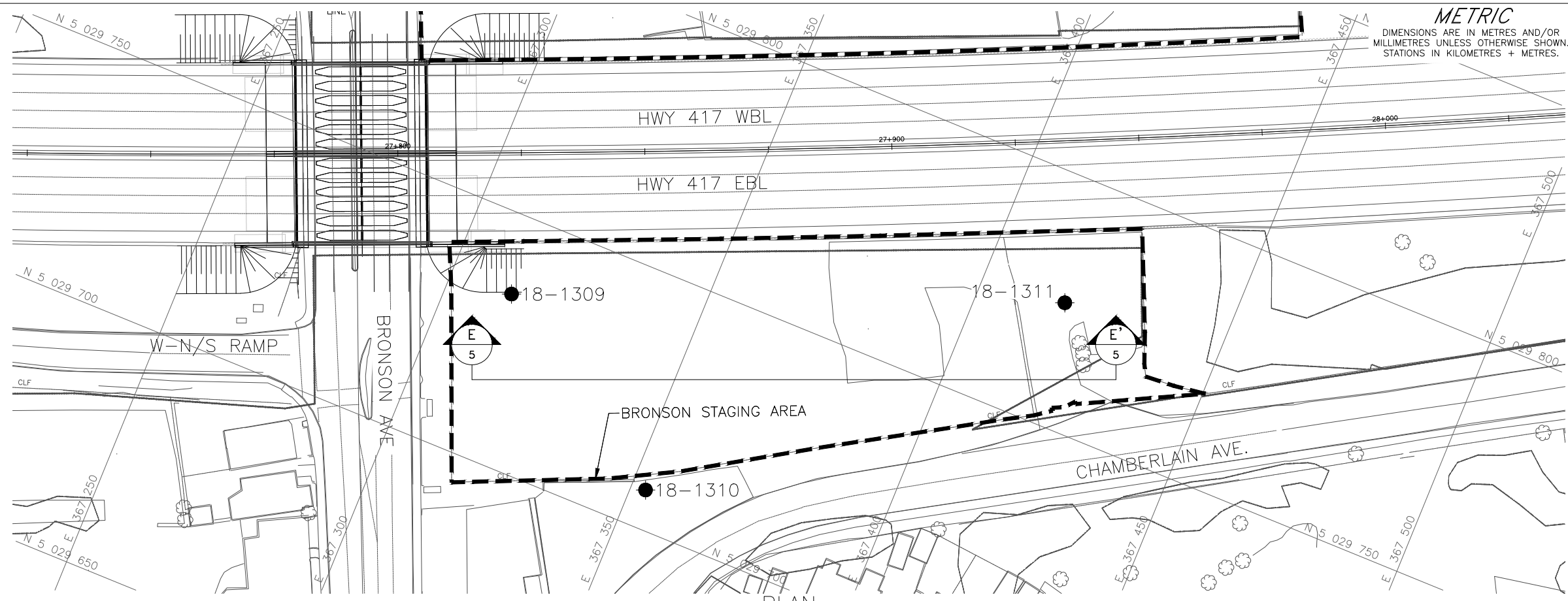

METRIC
 DIMENSIONS ARE IN METRES AND/OR MILLIMETRES UNLESS OTHERWISE SHOWN. STATIONS IN KILOMETRES + METRES.

CONT No. GWP No. 4173-15-00

HIGHWAY 417 OVERPASS STRUCTURE AT BRONSON AVENUE
 STAGING AREA
 BOREHOLE LOCATIONS AND SOIL STRATA
 LAT. 45.404786 LONG. -75.701075

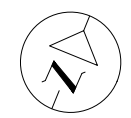

KEY PLAN
 SCALE
 500 0 500 1000 m

PLAN
 SCALE
 10 0 10 20 m



LEGEND

- Borehole - Current Investigation
- ⊥ Seal
- ⊏ Piezometer
- N Standard Penetration Test Value
- 16 Blows/0.3m unless otherwise stated (Std. Pen. Test, 475 j/blow)
- 100% Rock Quality Designation (RQD)
- ≡ WL in piezometer, measured on December 6, 2018
- ≡ WL upon completion of drilling

BOREHOLE CO-ORDINATES NAD83 (CSRS)/MTM ZONE 9

No.	ELEVATION	NORTHING	EASTING
18-1309	70.1	5029734.2	367312.9
18-1310	71.9	5029707.8	367353.0
18-1311	70.1	5029774.9	367417.2

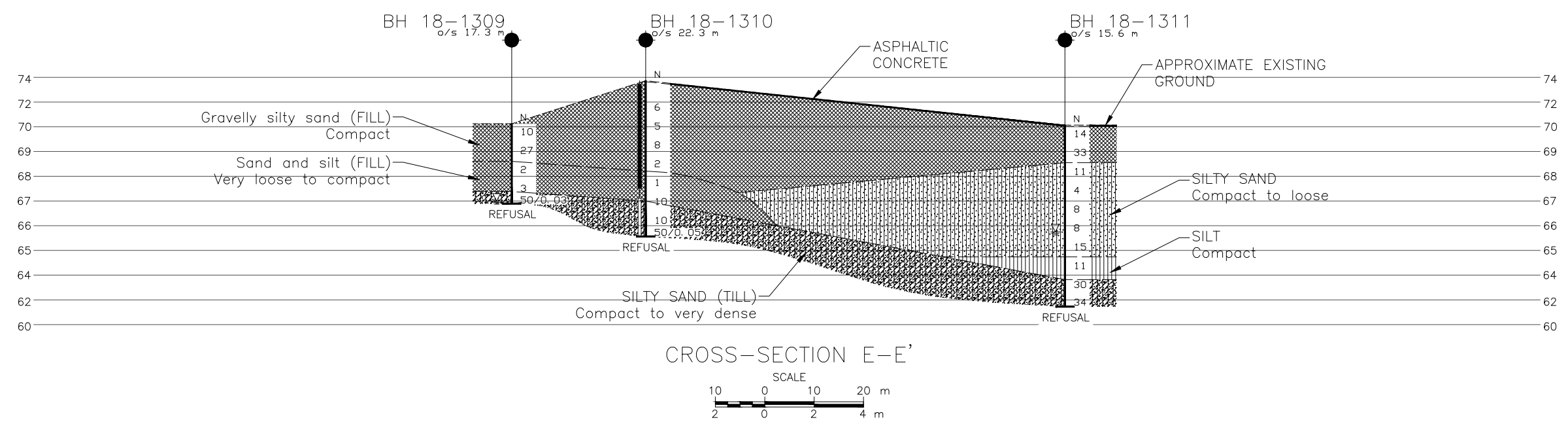

CROSS-SECTION E-E'
 SCALE
 10 0 10 20 m
 2 0 2 4 m

NOTES

This drawing is for subsurface information only. The proposed structure details/works are shown for illustration purposes only and may not be consistent with the final design configuration as shown elsewhere in the Contracts Documents.

The boundaries between soil strata have been established only at borehole locations. Between boreholes the boundaries are assumed from geological evidence.

REFERENCE

Base plans provided in digital format by WSP Canada Group Limited, drawing file no. S3416024-307-001GA.dwg, received MAY. 7, 2019.

NO.	DATE	BY	REVISION

Geocres No. 31G5-306

HWY. 417	PROJECT NO. 1655214-1130	DIST. EASTERN
SUBM'D. KP	CHKD. KP	DATE: 2/28/2019
DRAWN: JM	CHKD. FJH	APPD. FJH
		SITE: 3-60/1&2
		DWG. 5

APPENDIX A

Record of Boreholes, Current Investigation
Lists of Abbreviations and Symbols
Lithological and Geotechnical Rock Description Terminology
Record of Coreholes/Drillholes 17-C01 to 17-C24
Records of Boreholes 17-131 to 17-134
Records of Boreholes 18-1301 to 18-1311
Bedrock Core Photographs, Figures A1 to A32
Table A1 - Concrete Core Condition Assessment

LIST OF SYMBOLS

Unless otherwise stated, the symbols employed in the report are as follows:

I.	GENERAL	(a)	Index Properties (continued)
π	3.1416	w	water content
$\ln x$,	natural logarithm of x	w_l or LL	liquid limit
\log_{10}	x or log x, logarithm of x to base 10	w_p or PL	plastic limit
g	acceleration due to gravity	I_p or PI	plasticity index = $(w_l - w_p)$
t	time	w_s	shrinkage limit
FoS	factor of safety	I_L	liquidity index = $(w - w_p) / I_p$
		I_C	consistency index = $(w_l - w) / I_p$
		e_{max}	void ratio in loosest state
		e_{min}	void ratio in densest state
		I_D	density index = $(e_{max} - e) / (e_{max} - e_{min})$ (formerly relative density)
II.	STRESS AND STRAIN	(b)	Hydraulic Properties
γ	shear strain	h	hydraulic head or potential
Δ	change in, e.g. in stress: $\Delta \sigma$	q	rate of flow
ε	linear strain	v	velocity of flow
ε_v	volumetric strain	i	hydraulic gradient
η	coefficient of viscosity	k	hydraulic conductivity (coefficient of permeability)
ν	Poisson's ratio	j	seepage force per unit volume
	total stress		
σ'	effective stress ($\sigma' = \sigma - u$)	(c)	Consolidation (one-dimensional)
σ'_{vo}	initial effective overburden stress	C	compression index (normally consolidated range)
$\sigma_1, \sigma_2, \sigma_3$	principal stress (major, minor)	C_r	recompression index (over-consolidated range)
σ_{oct}	mean stress or octahedral stress = $(\sigma_1 + \sigma_2 + \sigma_3)/3$	C_s	swelling index
τ	shear stress	C_α	secondary compression index
u	porewater pressure	m_v	coefficient of volume change
E	modulus of deformation	c_v	coefficient of consolidation (vertical direction)
G	shear modulus of deformation	C_h	coefficient of consolidation (horizontal direction)
K	bulk modulus of compressibility	T_v	time factor (vertical direction)
		U	degree of consolidation
III.	SOIL PROPERTIES	σ'_p	pre-consolidation stress
(a)	Index Properties	OCR	over-consolidation ratio = σ'_p / σ'_{vo}
$\rho(\gamma)$	bulk density (bulk unit weight)*	(d)	Shear Strength
$\rho_d(\gamma_d)$	dry density (dry unit weight)	τ_p, τ_r	peak and residual shear strength
$\rho_w(\gamma_w)$	density (unit weight) of water	ϕ'	effective angle of internal friction
$\rho_s(\gamma_s)$	density (unit weight) of solid particles	δ	angle of interface friction
γ'	unit weight of submerged soil ($\gamma' = \gamma - \gamma_w$)	μ	coefficient of friction = $\tan \delta$
D_R	relative density (specific gravity) of solid particles ($D_R = \rho_s / \rho_w$) (formerly G_s)	c'	effective cohesion
e	void ratio	C_u, S_u	undrained shear strength ($\phi = 0$ analysis)
n	porosity	p	mean total stress $(\sigma_1 + \sigma_3)/2$
S	degree of saturation	p'	mean effective stress $(\sigma'_1 + \sigma'_3)/2$
		q	$(\sigma_1 - \sigma_3)/2$ or $(\sigma'_1 - \sigma'_3)/2$
		q_u	compressive strength $(\sigma_1 - \sigma_3)$
		S_t	sensitivity
* Density symbol is ρ . Unit weight symbol is γ where $\gamma = \rho g$ (i.e. mass density multiplied by acceleration due to gravity)		Notes: 1	$\tau = c' + \sigma' \tan \phi'$
		2	shear strength = (compressive strength)/2

LIST OF ABBREVIATIONS

The abbreviations commonly employed on Records of Boreholes, on figures and in the text of the report are as follows:

I. SAMPLE TYPE

AS	Auger sample
BS	Block sample
CS	Chunk sample
DS	Denison type sample
FS	Foil sample
RC	Rock core
SC	Soil core
SS	Split-spoon
ST	Slotted tube
TO	Thin-walled, open
TP	Thin-walled, piston
WS	Wash sample

II. PENETRATION RESISTANCE

Standard Penetration Resistance (SPT), N:

The number of blows by a 63.5 kg. (140 lb.) hammer dropped 760 mm (30 in.) required to drive a 50 mm (2 in.) drive open sampler for a distance of 300 mm (12 in.)

Dynamic Cone Penetration Resistance; N_d :

The number of blows by a 63.5 kg (140 lb.) hammer dropped 760 mm (30 in.) to drive uncased a 50 mm (2 in.) diameter, 60° cone attached to "A" size drill rods for a distance of 300 mm (12 in.).

PH: Sampler advanced by hydraulic pressure

PM: Sampler advanced by manual pressure

WH: Sampler advanced by static weight of hammer

WR: Sampler advanced by weight of sampler and rod

Piezo-Cone Penetration Test (CPT)

A electronic cone penetrometer with a 60° conical tip and a project end area of 10 cm² pushed through ground at a penetration rate of 2 cm/s. Measurements of tip resistance (Q_t), porewater pressure (PWP) and friction along a sleeve are recorded electronically at 25 mm penetration intervals.

V. MINOR SOIL CONSTITUENTS

Per cent by Weight	Modifier	Example
0 to 5	Trace	Trace sand
5 to 12	Trace to Some (or Little)	Trace to some sand
12 to 20	Some	Some sand
20 to 30	(ey) or (y)	Sandy
over 30	And (non-cohesive (cohesionless)) or With (cohesive)	Sand and Gravel Silty Clay with sand / Clayey Silt with sand

III. SOIL DESCRIPTION

(a) Non-Cohesive (Cohesionless) Soils

Compactness	N
Condition	Blows/300 mm or Blows/ft
Very loose	0 to 4
Loose	4 to 10
Compact	10 to 30
Dense	30 to 50
Very dense	over 50

(b) Cohesive Soils Consistency

	c_u, s_u	
	kPa	psf
Very soft	0 to 12	0 to 250
Soft	12 to 25	250 to 500
Firm	25 to 50	500 to 1,000
Stiff	50 to 100	1,000 to 2,000
Very stiff	100 to 200	2,000 to 4,000
Hard	over 200	over 4,000

IV. SOIL TESTS

w	water content
w _p	plastic limit
w _l	liquid limit
C	consolidation (oedometer) test
CHEM	chemical analysis (refer to text)
CID	consolidated isotropically drained triaxial test ¹
CIU	consolidated isotropically undrained triaxial test with porewater pressure measurement ¹
D _R	relative density (specific gravity, G _s)
DS	direct shear test
M	sieve analysis for particle size
MH	combined sieve and hydrometer (H) analysis
MPC	Modified Proctor compaction test
SPC	Standard Proctor compaction test
OC	organic content test
SO ₄	concentration of water-soluble sulphates
UC	unconfined compression test
UU	unconsolidated undrained triaxial test
V	field vane (LV-laboratory vane test)
γ	unit weight

Note: 1 Tests which are anisotropically consolidated prior to shear are shown as CAD, CAU.

LITHOLOGICAL AND GEOTECHNICAL ROCK DESCRIPTION TERMINOLOGY

WEATHERINGS STATE

Fresh: no visible sign of weathering

Faintly weathered: weathering limited to the surface of major discontinuities.

Slightly weathered: penetrative weathering developed on open discontinuity surfaces but only slight weathering of rock material.

Moderately weathered: weathering extends throughout the rock mass but the rock material is not friable.

Highly weathered: weathering extends throughout rock mass and the rock material is partly friable.

Completely weathered: rock is wholly decomposed and in a friable condition but the rock and structure are preserved.

BEDDING THICKNESS

<u>Description</u>	<u>Bedding Plane Spacing</u>
Very thickly bedded	Greater than 2 m
Thickly bedded	0.6 m to 2 m
Medium bedded	0.2 m to 0.6 m
Thinly bedded	60 mm to 0.2 m
Very thinly bedded	20 mm to 60 mm
Laminated	6 mm to 20 mm
Thinly laminated	Less than 6 mm

JOINT OR FOLIATION SPACING

<u>Description</u>	<u>Spacing</u>
Very wide	Greater than 3 m
Wide	1 m to 3 m
Moderately close	0.3 m to 1 m
Close	50 mm to 300 mm
Very close	Less than 50 mm

GRAIN SIZE

<u>Term</u>	<u>Size*</u>
Very Coarse Grained	Greater than 60 mm
Coarse Grained	2 mm to 60 mm
Medium Grained	60 microns to 2 mm
Fine Grained	2 microns to 60 microns
Very Fine Grained	Less than 2 microns

Note: * Grains greater than 60 microns diameter are visible to the naked eye.

CORE CONDITION

Total Core Recovery (TCR)

The percentage of solid drill core recovered regardless of quality or length, measured relative to the length of the total core run.

Solid Core Recovery (SCR)

The percentage of solid drill core, regardless of length, recovered at full diameter, measured relative to the length of the total core run.

Rock Quality Designation (RQD)

The percentage of solid drill core, greater than 100 mm length, as measured along the centerline axis of the core, relative to the length of the total core run. RQD varies from 0% for completely broken core to 100% for core in solid segments.

DISCONTINUITY DATA

Fracture Index

A count of the number of discontinuities (physical separations) in the rock core, including both naturally occurring fractures and mechanically induced breaks caused by drilling.

Dip with Respect to Core Axis

The angle of the discontinuity relative to the axis (length) of the core. In a vertical borehole a discontinuity with a 90° angle is horizontal.

Description and Notes

An abbreviation description of the discontinuities, whether naturally occurring separations such as fractures, bedding planes and foliation planes or mechanically induced features caused by drilling such as ground or shattered core and mechanically separated bedding or foliation surfaces. Additional information concerning the nature of fracture surfaces and infillings are also noted.

Abbreviations

JN Joint	PL Planar
FLT Fault	CU Curved
SH Shear	UN Undulating
VN Vein	IR Irregular
FR Fracture	K Slickensided
SY Stylolite	PO Polished
BD Bedding	SM Smooth
FO Foliation	SR Slightly Rough
CO Contact	RO Rough
AXJ Axial Joint	VR Very Rough
KV Karstic Void	
MB Mechanical Break	

PROJECT <u>1655214-1130</u>	RECORD OF COREHOLE No 17-C01	SHEET 1 OF 1	METRIC
G.W.P. <u>4173-15-00</u>	LOCATION <u>N 5029769.3; E 367278.0 NAD 83 MTM ZONE 9 (LAT. 45.405082; LONG. -75.701882)</u>	ORIGINATED BY <u>PAH</u>	
DIST <u>Eastern</u> HWY <u>417</u>	BOREHOLE TYPE <u>Portable Drill/Hydro-excavation</u>	COMPILED BY <u>ZS</u>	
DATUM <u>Geodetic</u>	DATE <u>July 31 to August 1, 2017</u>	CHECKED BY <u>KCP</u>	

SOIL PROFILE		SAMPLES			GROUND WATER CONDITIONS	ELEVATION SCALE	DYNAMIC CONE PENETRATION RESISTANCE PLOT					PLASTIC NATURAL LIQUID LIMIT MOISTURE LIMIT CONTENT			UNIT WEIGHT γ kN/m ³	REMARKS & GRAIN SIZE DISTRIBUTION (%)					
ELEV DEPTH	DESCRIPTION	STRAT PLOT	NUMBER	TYPE			"N" VALUES	20	40	60	80	100	W _p	W			W _L	25	50	75	GR
69.5	GROUND SURFACE																				
0.0 69.4	PORTLAND CEMENT CONCRETE (SIDEWALK)																				
69.3 0.2	(SP/GP) Sand and gravel, trace silt (FILL) Grey Moist (SP) Sand, some gravel (FILL) Brown Moist		1	GRAB	-							o						35	55	8	2
68.5 1.1	END OF COREHOLE AT TOP OF FOOTING NOTES: 1. Corehole continued on Record of Drillhole 17-C01D.		2	GRAB	-																

GTA-MTO 001 N:\ACTIVE\SPATIAL_IMMTO\HWY417REHAB&WIDENING02_DATA\GINT\1655214.GPJ GAL-GTA.GDT 6/6/19 JIM

+³, ×³: Numbers refer to Sensitivity ○ 3% STRAIN AT FAILURE

PROJECT <u>1655214-1130</u>	RECORD OF COREHOLE No 17-C02	SHEET 1 OF 1	METRIC
G.W.P. <u>4173-15-00</u>	LOCATION <u>N 5029766.5; E 367279.1 NAD 83 MTM ZONE 9 (LAT. 45.405056; LONG. -75.701868)</u>	ORIGINATED BY <u>DG</u>	
DIST <u>Eastern</u> HWY <u>417</u>	BOREHOLE TYPE <u>Portable Drill/Hydro-excavation</u>	COMPILED BY <u>ZS</u>	
DATUM <u>Geodetic</u>	DATE <u>July 28, 2017</u>	CHECKED BY <u>KCP</u>	

SOIL PROFILE		SAMPLES			GROUND WATER CONDITIONS	ELEVATION SCALE	DYNAMIC CONE PENETRATION RESISTANCE PLOT					PLASTIC LIMIT W _p	NATURAL MOISTURE CONTENT W	LIQUID LIMIT W _L	UNIT WEIGHT γ	REMARKS & GRAIN SIZE DISTRIBUTION (%) GR SA SI CL
ELEV DEPTH	DESCRIPTION	STRAT PLOT	NUMBER	TYPE			"N" VALUES	20	40	60	80					
69.4	GROUND SURFACE															
0.0	PORTLAND CEMENT CONCRETE (SIDEWALK)															
69.3	(SP) Sand (FILL) Brown Moist															
0.1																
68.9	(SP) Sand, contains concrete fragments (FILL) Brown Moist															
0.5																
68.4	END OF COREHOLE AT TOP OF FOOTING															
1.0																

GTA-MTO 001 N:\ACTIVE\SPATIAL_IMMTO\HWY417REHAB&WIDENING02_DATA\GINT\1655214.GPJ GAL-GTA.GDT 6/6/19 JIM

+³, ×³: Numbers refer to Sensitivity ○ 3% STRAIN AT FAILURE

PROJECT <u>1655214-1130</u>	RECORD OF COREHOLE No 17-C03	SHEET 1 OF 1	METRIC
G.W.P. <u>4173-15-00</u>	LOCATION <u>N 5029763.6; E 367280.3 NAD 83 MTM ZONE 9 (LAT. 45.405030; LONG. -75.701853)</u>	ORIGINATED BY <u>DG</u>	
DIST <u>Eastern</u> HWY <u>417</u>	BOREHOLE TYPE <u>Portable Drill/Hydro-excavation</u>	COMPILED BY <u>ZS</u>	
DATUM <u>Geodetic</u>	DATE <u>July 28, 2017</u>	CHECKED BY <u>KCP</u>	

SOIL PROFILE		SAMPLES			GROUND WATER CONDITIONS	ELEVATION SCALE	DYNAMIC CONE PENETRATION RESISTANCE PLOT					PLASTIC NATURAL LIQUID LIMIT MOISTURE LIMIT CONTENT			UNIT WEIGHT γ kN/m ³	REMARKS & GRAIN SIZE DISTRIBUTION (%) GR SA SI CL		
ELEV DEPTH	DESCRIPTION	STRAT PLOT	NUMBER	TYPE			"N" VALUES	20	40	60	80	100	W _p	W			W _L	25
69.4	GROUND SURFACE																	
0.0	PORTLAND CEMENT CONCRETE (SIDEWALK)																	
0.1	(SP) Sand, some gravel (FILL) Grey Moist		1	GRAB	-													
69.1	(SP) Sand (FILL) Brown Moist																	
0.3																		
68.4			2	GRAB	-													
1.0	END OF COREHOLE AT TOP OF FOOTING																	

GTA-MTO 001 N:\ACTIVE\SPATIAL_IMMTO\HWY417REHAB&WIDENING02_DATA\GINT\1655214.GPJ GAL-GTA.GDT 6/6/19 JIM

+³, ×³: Numbers refer to Sensitivity ○ 3% STRAIN AT FAILURE

PROJECT <u>1655214-1130</u>	RECORD OF COREHOLE No 17-C04	SHEET 1 OF 1	METRIC
G.W.P. <u>4173-15-00</u>	LOCATION <u>N 5029761.0; E 367281.5 NAD 83 MTM ZONE 9 (LAT. 45.405007; LONG. -75.701838)</u>	ORIGINATED BY <u>PAH</u>	
DIST <u>Eastern</u> HWY <u>417</u>	BOREHOLE TYPE <u>Portable Drill/Hydro-excavation</u>	COMPILED BY <u>ZS</u>	
DATUM <u>Geodetic</u>	DATE <u>July 28, 2017</u>	CHECKED BY <u>KCP</u>	

SOIL PROFILE		SAMPLES			GROUND WATER CONDITIONS	ELEVATION SCALE	DYNAMIC CONE PENETRATION RESISTANCE PLOT					PLASTIC NATURAL LIQUID LIMIT MOISTURE LIMIT CONTENT			UNIT WEIGHT γ kN/m ³	REMARKS & GRAIN SIZE DISTRIBUTION (%) GR SA SI CL		
ELEV DEPTH	DESCRIPTION	STRAT PLOT	NUMBER	TYPE			"N" VALUES	20	40	60	80	100	W _p	W			W _L	25
69.5	GROUND SURFACE	[Pattern]																
0.0 69.4	PORTLAND CEMENT CONCRETE (SIDEWALK)	[Pattern]																
0.1	(SP) Gravelly sand (FILL) Grey	[Pattern]	1	GRAB	-													
69.3 0.3	Moist (SP) Sand, some gravel (FILL) Brown Moist	[Pattern]																
68.4		[Pattern]	2	GRAB	-													
1.1	END OF COREHOLE AT TOP OF FOOTING NOTES: 1. Corehole continued on Record of Drillhole 17-C04D.																	

GTA-MTO 001 N:\ACTIVE\SPATIAL_IMMTO\HWY417REHAB&WIDENING\02_DATA\GINT\1655214.GPJ GAL-GTA.GDT 6/6/19 JIM

+³, ×³: Numbers refer to Sensitivity ○ 3% STRAIN AT FAILURE

PROJECT <u>1655214-1130</u>	RECORD OF COREHOLE No 17-C05	SHEET 1 OF 1	METRIC
G.W.P. <u>4173-15-00</u>	LOCATION <u>N 5029757.8; E 367282.8 NAD 83 MTM ZONE 9 (LAT. 45.404978; LONG. -75.701822)</u>	ORIGINATED BY <u>DG</u>	
DIST <u>Eastern</u> HWY <u>417</u>	BOREHOLE TYPE <u>Portable Drill/Hydro-excavation</u>	COMPILED BY <u>ZS</u>	
DATUM <u>Geodetic</u>	DATE <u>July 28, 2017</u>	CHECKED BY <u>KCP</u>	

SOIL PROFILE		SAMPLES			GROUND WATER CONDITIONS	ELEVATION SCALE	DYNAMIC CONE PENETRATION RESISTANCE PLOT					PLASTIC LIMIT W _p	NATURAL MOISTURE CONTENT W	LIQUID LIMIT W _L	UNIT WEIGHT γ	REMARKS & GRAIN SIZE DISTRIBUTION (%) GR SA SI CL
ELEV DEPTH	DESCRIPTION	STRAT PLOT	NUMBER	TYPE			"N" VALUES	20	40	60	80					
69.5	GROUND SURFACE															
69.4	PORTLAND CEMENT CONCRETE (SIDEWALK)															
0.1	(SP) Gravelly sand (FILL) Grey Moist															
69.2																
0.3	(SP) Sand (FILL) Brown Moist															
69.0																
0.5	END OF COREHOLE															
	NOTES: 1. Refusal to hydro-excavation on conduit at 0.5 m below ground surface.															

GTA-MTO 001 N:\ACTIVE\SPATIAL_IMMTO\HWY417REHAB&WIDENING\02_DATA\GINT\1655214.GPJ GAL-GTA.GDT 6/6/19 JIM

+³, ×³: Numbers refer to Sensitivity ○ 3% STRAIN AT FAILURE

PROJECT <u>1655214-1130</u>	RECORD OF COREHOLE No 17-C06	SHEET 1 OF 1	METRIC
G.W.P. <u>4173-15-00</u>	LOCATION <u>N 5029754.8; E 367284.0 NAD 83 MTM ZONE 9 (LAT. 45.404951; LONG. -75.701807)</u>	ORIGINATED BY <u>DG</u>	
DIST <u>Eastern</u> HWY <u>417</u>	BOREHOLE TYPE <u>Portable Drill/Hydro-excavation</u>	COMPILED BY <u>ZS</u>	
DATUM <u>Geodetic</u>	DATE <u>July 28, 2017</u>	CHECKED BY <u>KCP</u>	

SOIL PROFILE		SAMPLES			GROUND WATER CONDITIONS	ELEVATION SCALE	DYNAMIC CONE PENETRATION RESISTANCE PLOT					PLASTIC LIMIT W _p	NATURAL MOISTURE CONTENT W	LIQUID LIMIT W _L	UNIT WEIGHT γ kN/m ³	REMARKS & GRAIN SIZE DISTRIBUTION (%) GR SA SI CL
ELEV DEPTH	DESCRIPTION	STRAT PLOT	NUMBER	TYPE			"N" VALUES	20	40	60	80					
69.6	GROUND SURFACE															
0.0	PORTLAND CEMENT CONCRETE (SIDEWALK)															
69.5	(SP) Gravelly sand (FILL) Grey Moist															
69.4	(SP) Sand (FILL) Brown Moist															
0.2																
69.0	END OF COREHOLE					69										
0.6	NOTES: 1. Refusal to hydro-excavation on conduit at 0.6 m below ground surface.															

GTA-MTO 001 N:\ACTIVE\SPATIAL_IMMTO\HWY417REHAB&WIDENING02_DATA\GINT\1655214.GPJ GAL-GTA.GDT 6/6/19 JIM

+³, ×³: Numbers refer to Sensitivity ○ 3% STRAIN AT FAILURE

PROJECT <u>1655214-1130</u>	RECORD OF COREHOLE No 17-C07	SHEET 1 OF 1	METRIC
G.W.P. <u>4173-15-00</u>	LOCATION <u>N 5029751.7; E 367285.3 NAD 83 MTM ZONE 9 (LAT. 45.404923; LONG. -75.701791)</u>	ORIGINATED BY <u>DG</u>	
DIST <u>Eastern</u> HWY <u>417</u>	BOREHOLE TYPE <u>Portable Drill/Hydro-excavation</u>	COMPILED BY <u>ZS</u>	
DATUM <u>Geodetic</u>	DATE <u>July 28, 2017</u>	CHECKED BY <u>KCP</u>	

SOIL PROFILE		SAMPLES			GROUND WATER CONDITIONS	ELEVATION SCALE	DYNAMIC CONE PENETRATION RESISTANCE PLOT					PLASTIC LIMIT NATURAL MOISTURE CONTENT LIQUID LIMIT			UNIT WEIGHT γ kN/m ³	REMARKS & GRAIN SIZE DISTRIBUTION (%) GR SA SI CL
ELEV DEPTH	DESCRIPTION	STRAT PLOT	NUMBER	TYPE			"N" VALUES	20	40	60	80	100	W _p	W		
69.7	GROUND SURFACE															
0.0	PORTLAND CEMENT CONCRETE (SIDEWALK)															
69.6	(SP) Gravelly sand (FILL) Grey Moist		1	GRAB	-											
69.4	(SP) Sand (FILL) Brown Moist															
0.3																
69.2	END OF COREHOLE															
0.5	NOTES: 1. Refusal to hydro-excavation on conduit at 0.5 m below ground surface.															

GTA-MTO 001 N:\ACTIVE\SPATIAL_IMMTO\HWY417REHAB&WIDENING\02_DATA\GINT\1655214.GPJ GAL-GTA.GDT 6/6/19 JIM

+³, ×³: Numbers refer to Sensitivity ○ 3% STRAIN AT FAILURE

PROJECT <u>1655214-1130</u>	RECORD OF COREHOLE No 17-C08	SHEET 1 OF 1	METRIC
G.W.P. <u>4173-15-00</u>	LOCATION <u>N 5029748.6; E 367286.6 NAD 83 MTM ZONE 9 (LAT. 45.404895; LONG. -75.701775)</u>	ORIGINATED BY <u>DG</u>	
DIST <u>Eastern</u> HWY <u>417</u>	BOREHOLE TYPE <u>Portable Drill/Hydro-excavation</u>	COMPILED BY <u>ZS</u>	
DATUM <u>Geodetic</u>	DATE <u>July 28, 2017</u>	CHECKED BY <u>KCP</u>	

SOIL PROFILE		SAMPLES			GROUND WATER CONDITIONS	ELEVATION SCALE	DYNAMIC CONE PENETRATION RESISTANCE PLOT					PLASTIC NATURAL LIQUID LIMIT MOISTURE LIMIT CONTENT			UNIT WEIGHT γ kN/m ³	REMARKS & GRAIN SIZE DISTRIBUTION (%) GR SA SI CL		
ELEV DEPTH	DESCRIPTION	STRAT PLOT	NUMBER	TYPE			"N" VALUES	20	40	60	80	100	W _p	W			W _L	25
69.7	GROUND SURFACE																	
0.0 69.6	PORTLAND CEMENT CONCRETE (SIDEWALK)																	
0.1	(SP) Gravelly sand (FILL) Grey																	
69.5 0.3	Moist (SP) Sand (FILL) Brown Moist																	
68.9 0.8	END OF COREHOLE					69												
	NOTES: 1. Refusal to hydro-excavation on conduit at 0.8 m below ground surface.																	

GTA-MTO 001 N:\ACTIVE\SPATIAL_IMMTO\HWY417REHAB&WIDENING02_DATA\GINT\1655214.GPJ GAL-GTA.GDT 6/6/19 JIM

PROJECT <u>1655214-1130</u>	RECORD OF COREHOLE No 17-C09	SHEET 1 OF 1	METRIC
G.W.P. <u>4173-15-00</u>	LOCATION <u>N 5029745.6; E 367287.8 NAD 83 MTM ZONE 9 (LAT. 45.404868; LONG. -75.701760)</u>	ORIGINATED BY <u>DG</u>	
DIST <u>Eastern</u> HWY <u>417</u>	BOREHOLE TYPE <u>Portable Drill/Hydro-excavation</u>	COMPILED BY <u>ZS</u>	
DATUM <u>Geodetic</u>	DATE <u>July 27, 2017</u>	CHECKED BY <u>KCP</u>	

SOIL PROFILE		SAMPLES			GROUND WATER CONDITIONS	ELEVATION SCALE	DYNAMIC CONE PENETRATION RESISTANCE PLOT					PLASTIC NATURAL LIQUID LIMIT MOISTURE LIMIT CONTENT			UNIT WEIGHT γ kN/m ³	REMARKS & GRAIN SIZE DISTRIBUTION (%)						
ELEV DEPTH	DESCRIPTION	STRAT PLOT	NUMBER	TYPE			"N" VALUES	20	40	60	80	100	W _p	W			W _L	25	50	75	GR	SA
69.8	GROUND SURFACE																					
0.0 69.7	PORTLAND CEMENT CONCRETE (SIDEWALK)																					
69.6 0.2	(SP) Sand, some gravel (FILL) Grey Moist		1	GRAB	-																	14 81 4 1
	(SP) Sand, some gravel, trace silt (FILL) Brown Moist																					
68.7 1.1	END OF COREHOLE AT TOP OF FOOTING																					
	NOTES: 1. Corehole continued on Record of Drillhole 17-C09D.																					

GTA-MTO 001 N:\ACTIVE\SPATIAL_IMMTO\HWY417REHAB&WIDENING02_DATA\GINT\1655214.GPJ GAL-GTA.GDT 6/6/19 JIM

PROJECT <u>1655214-1130</u>	RECORD OF COREHOLE No 17-C10	SHEET 1 OF 1	METRIC
G.W.P. <u>4173-15-00</u>	LOCATION <u>N 5029742.5; E 367289.2 NAD 83 MTM ZONE 9 (LAT. 45.404840; LONG. -75.701742)</u>	ORIGINATED BY <u>DG</u>	
DIST <u>Eastern</u> HWY <u>417</u>	BOREHOLE TYPE <u>Portable Drill/Hydro-excavation</u>	COMPILED BY <u>ZS</u>	
DATUM <u>Geodetic</u>	DATE <u>July 27, 2017</u>	CHECKED BY <u>KCP</u>	

SOIL PROFILE		SAMPLES			GROUND WATER CONDITIONS	ELEVATION SCALE	DYNAMIC CONE PENETRATION RESISTANCE PLOT					PLASTIC NATURAL LIQUID LIMIT MOISTURE LIMIT CONTENT			UNIT WEIGHT γ kN/m ³	REMARKS & GRAIN SIZE DISTRIBUTION (%) GR SA SI CL		
ELEV DEPTH	DESCRIPTION	STRAT PLOT	NUMBER	TYPE			"N" VALUES	20	40	60	80	100	W _p	W			W _L	25
69.8	GROUND SURFACE																	
0.0 69.7	PORTLAND CEMENT CONCRETE (SIDEWALK)																	
0.1	(SP) Gravelly sand (FILL) Grey Moist		1	GRAB	-													
69.5 0.3	(SP) Sand, trace gravel (FILL) Brown Moist																	
68.6 1.2	END OF COREHOLE AT TOP OF FOOTING		2	GRAB	-	69												

GTA-MTO 001 N:\ACTIVE\SPATIAL_IMMTO\HWY417REHAB&WIDENING02_DATA\GINT\1655214.GPJ GAL-GTA.GDT 6/6/19 JIM

PROJECT <u>1655214-1130</u>	RECORD OF COREHOLE No 17-C11	SHEET 1 OF 1	METRIC
G.W.P. <u>4173-15-00</u>	LOCATION <u>N 5029739.3; E 367290.6 NAD 83 MTM ZONE 9 (LAT. 45.404811; LONG. -75.701725)</u>	ORIGINATED BY <u>DG</u>	
DIST <u>Eastern</u> HWY <u>417</u>	BOREHOLE TYPE <u>Portable Drill/Hydro-excavation</u>	COMPILED BY <u>ZS</u>	
DATUM <u>Geodetic</u>	DATE <u>July 27, 2017</u>	CHECKED BY <u>KCP</u>	

SOIL PROFILE		SAMPLES			GROUND WATER CONDITIONS	ELEVATION SCALE	DYNAMIC CONE PENETRATION RESISTANCE PLOT					PLASTIC NATURAL LIQUID LIMIT MOISTURE LIMIT CONTENT			UNIT WEIGHT γ kN/m ³	REMARKS & GRAIN SIZE DISTRIBUTION (%) GR SA SI CL		
ELEV DEPTH	DESCRIPTION	STRAT PLOT	NUMBER	TYPE			"N" VALUES	20	40	60	80	100	W _p	W			W _L	25
69.9	GROUND SURFACE																	
0.0	PORTLAND CEMENT CONCRETE (SIDEWALK)																	
69.8	(SP) Gravelly sand (FILL) Grey Moist																	
0.1																		
69.6	(SP) Sand (FILL) Brown Moist																	
0.3																		
68.9						69												
1.0	END OF COREHOLE AT TOP OF FOOTING																	
	NOTES: 1. Corehole continued on Record of Drillhole 17-C11D.																	

GTA-MTO 001 N:\ACTIVE\SPATIAL_IMMTO\HWY417REHAB&WIDENING02_DATA\GINT\1655214.GPJ GAL-GTA.GDT 6/6/19 JIM

+³, ×³: Numbers refer to Sensitivity ○ 3% STRAIN AT FAILURE

PROJECT <u>1655214-1130</u>	RECORD OF COREHOLE No 17-C12	SHEET 1 OF 1	METRIC
G.W.P. <u>4173-15-00</u>	LOCATION <u>N 5029736.4; E 367291.7 NAD 83 MTM ZONE 9 (LAT. 45.404784; LONG. -75.701711)</u>	ORIGINATED BY <u>DG</u>	
DIST <u>Eastern</u> HWY <u>417</u>	BOREHOLE TYPE <u>Portable Drill/Hydro-excavation</u>	COMPILED BY <u>ZS</u>	
DATUM <u>Geodetic</u>	DATE <u>July 27, 2017</u>	CHECKED BY <u>KCP</u>	

ELEV DEPTH	SOIL PROFILE DESCRIPTION	STRAT PLOT	SAMPLES			GROUND WATER CONDITIONS	ELEVATION SCALE	DYNAMIC CONE PENETRATION RESISTANCE PLOT					PLASTIC LIMIT W _p	NATURAL MOISTURE CONTENT W	LIQUID LIMIT W _L	UNIT WEIGHT γ kN/m ³	REMARKS & GRAIN SIZE DISTRIBUTION (%) GR SA SI CL
			NUMBER	TYPE	"N" VALUES			20	40	60	80	100					
70.0	GROUND SURFACE																
0.0	PORTLAND CEMENT CONCRETE (SIDEWALK)																
0.1	(SP) Gravelly sand (FILL) Grey	[Pattern]	1	GRAB	-												
69.8	Moist (SP) Sand, trace gravel (FILL) Brown		2	GRAB	-												
0.3	Moist																
69.0							69										
1.0	END OF COREHOLE AT TOP OF FOOTING																

GTA-MTO 001 N:\ACTIVE\SPATIAL_IMMTO\HWY417REHAB&WIDENING\02_DATA\GINT\1655214.GPJ GAL-GTA.GDT 6/6/19 JIM

+³, ×³: Numbers refer to Sensitivity ○ 3% STRAIN AT FAILURE



PROJECT <u>1655214-1130</u>	RECORD OF COREHOLE No 17-C13	SHEET 1 OF 1	METRIC
G.W.P. <u>4173-15-00</u>	LOCATION <u>N 5029728.0; E 367270.1 NAD 83 MTM ZONE 9 (LAT. 45.404711; LONG. -75.701988)</u>	ORIGINATED BY <u>DG</u>	
DIST <u>Eastern</u> HWY <u>417</u>	BOREHOLE TYPE <u>Portable Drill/Hydro-excavation</u>	COMPILED BY <u>ZS</u>	
DATUM <u>Geodetic</u>	DATE <u>July 20, 2017</u>	CHECKED BY <u>KCP</u>	

SOIL PROFILE		SAMPLES			GROUND WATER CONDITIONS	ELEVATION SCALE	DYNAMIC CONE PENETRATION RESISTANCE PLOT					PLASTIC NATURAL LIQUID LIMIT MOISTURE LIMIT CONTENT CONTENT			UNIT WEIGHT γ kN/m ³	REMARKS & GRAIN SIZE DISTRIBUTION (%) GR SA SI CL		
ELEV DEPTH	DESCRIPTION	STRAT PLOT	NUMBER	TYPE			"N" VALUES	20	40	60	80	100	W _p	W			W _L	25
70.0	GROUND SURFACE																	
0.0	PORTLAND CEMENT CONCRETE (SIDEWALK)																	
0.1	(SP) Gravelly sand, trace silt (FILL) Grey Moist		1	GRAB	-						o							57 34 8 1
0.4	(SM/GM) Sand and gravel, some silt (FILL) Brown Moist		2	GRAB	-													
68.8	END OF COREHOLE AT TOP OF FOOTING					69												
1.2	NOTES: 1. Corehole continued on Record of Drillhole 17-C13D.																	

GTA-MTO 001 N:\ACTIVE\SPATIAL_IMMTO\HWY417REHAB&WIDENING\02_DATA\GINT\1655214.GPJ GAL-GTA.GDT 6/6/19 JIM

+³, ×³: Numbers refer to Sensitivity ○ 3% STRAIN AT FAILURE

PROJECT <u>1655214-1130</u>	RECORD OF COREHOLE No 17-C14	SHEET 1 OF 1	METRIC
G.W.P. <u>4173-15-00</u>	LOCATION <u>N 5029730.7; E 367268.9 NAD 83 MTM ZONE 9 (LAT. 45.404735; LONG. -75.702003)</u>	ORIGINATED BY <u>DG</u>	
DIST <u>Eastern</u> HWY <u>417</u>	BOREHOLE TYPE <u>Portable Drill/Hydro-excavation</u>	COMPILED BY <u>ZS</u>	
DATUM <u>Geodetic</u>	DATE <u>July 20, 2017</u>	CHECKED BY <u>KCP</u>	

SOIL PROFILE		SAMPLES			GROUND WATER CONDITIONS	ELEVATION SCALE	DYNAMIC CONE PENETRATION RESISTANCE PLOT					PLASTIC NATURAL LIQUID LIMIT MOISTURE LIMIT CONTENT			UNIT WEIGHT γ kN/m ³	REMARKS & GRAIN SIZE DISTRIBUTION (%) GR SA SI CL
ELEV DEPTH	DESCRIPTION	STRAT PLOT	NUMBER	TYPE			"N" VALUES	SHEAR STRENGTH kPa					WATER CONTENT (%)			
						20 40 60 80 100	20 40 60 80 100	20 40 60 80 100	20 40 60 80 100	20 40 60 80 100	20 40 60 80 100	25 50 75	25 50 75	25 50 75		
69.9	GROUND SURFACE															
0.0 69.8	PORTLAND CEMENT CONCRETE (SIDEWALK)															
0.1 69.5	(SP) Gravelly sand (FILL) Grey Moist															
0.4	END OF COREHOLE															
	NOTES: 1. Refusal to hydro-excavation on conduit at 0.4 m below ground surface.															

GTA-MTO 001 N:\ACTIVE\SPATIAL_IMMTO\HWY417REHAB&WIDENING\02_DATA\GINT\1655214.GPJ GAL-GTA.GDT 6/6/19 JIM

PROJECT <u>1655214-1130</u>	RECORD OF COREHOLE No 17-C15	SHEET 1 OF 1	METRIC
G.W.P. <u>4173-15-00</u>	LOCATION <u>N 5029733.8; E 367267.7 NAD 83 MTM ZONE 9 (LAT. 45.404763; LONG. -75.702018)</u>	ORIGINATED BY <u>DG</u>	
DIST <u>Eastern</u> HWY <u>417</u>	BOREHOLE TYPE <u>Portable Drill/Hydro-excavation</u>	COMPILED BY <u>ZS</u>	
DATUM <u>Geodetic</u>	DATE <u>July 20, 2017</u>	CHECKED BY <u>KCP</u>	

SOIL PROFILE		SAMPLES			GROUND WATER CONDITIONS	ELEVATION SCALE	DYNAMIC CONE PENETRATION RESISTANCE PLOT					PLASTIC NATURAL LIQUID LIMIT MOISTURE LIMIT CONTENT			UNIT WEIGHT γ kN/m ³	REMARKS & GRAIN SIZE DISTRIBUTION (%) GR SA SI CL		
ELEV DEPTH	DESCRIPTION	STRAT PLOT	NUMBER	TYPE			"N" VALUES	20	40	60	80	100	W _p	W			W _L	25
69.8	GROUND SURFACE																	
0.0	PORTLAND CEMENT CONCRETE (SIDEWALK)																	
69.7	(SP) Sand, some gravel (FILL)																	
0.1	Grey Moist		1	GRAB	-													
69.4	END OF COREHOLE AT																	
0.4	NOTES: 1. Refusal to hydro-excavation on conduit at 0.4 m below ground surface.																	

GTA-MTO 001 N:\ACTIVE\SPATIAL_IMMTO\HWY417REHAB&WIDENING\02_DATA\GINT\1655214.GPJ GAL-GTA.GDT 6/6/19 JIM

+³, ×³: Numbers refer to Sensitivity ○ 3% STRAIN AT FAILURE

PROJECT <u>1655214-1130</u>	RECORD OF COREHOLE No 17-C16	SHEET 1 OF 1	METRIC
G.W.P. <u>4173-15-00</u>	LOCATION <u>N 5029736.4; E 367266.5 NAD 83 MTM ZONE 9 (LAT. 45.404787; LONG. -75.702033)</u>	ORIGINATED BY <u>DG</u>	
DIST <u>Eastern</u> HWY <u>417</u>	BOREHOLE TYPE <u>Portable Drill/Hydro-excavation</u>	COMPILED BY <u>ZS</u>	
DATUM <u>Geodetic</u>	DATE <u>July 20, 2017</u>	CHECKED BY <u>KCP</u>	

SOIL PROFILE		SAMPLES			GROUND WATER CONDITIONS	ELEVATION SCALE	DYNAMIC CONE PENETRATION RESISTANCE PLOT					PLASTIC NATURAL LIQUID LIMIT			UNIT WEIGHT	REMARKS & GRAIN SIZE DISTRIBUTION (%)
ELEV. DEPTH	DESCRIPTION	STRAT PLOT	NUMBER	TYPE			"N" VALUES	20	40	60	80	100	W _p	W		
69.8	GROUND SURFACE															
0.0	PORTLAND CEMENT CONCRETE (SIDEWALK)															
69.7	(SP) Gravelly sand (FILL) Grey Moist															
0.1																
69.4	END OF COREHOLE															
0.4	NOTES: 1. Refusal to hydro-excavation on conduit at 0.4 m below ground surface.															

GTA-MTO 001 N:\ACTIVE\SPATIAL_IMMTO\HWY417REHAB&WIDENING\02_DATA\GINT\1655214.GPJ GAL-GTA.GDT 6/6/19 JIM

PROJECT <u>1655214-1130</u>	RECORD OF COREHOLE No 17-C17	SHEET 1 OF 1	METRIC
G.W.P. <u>4173-15-00</u>	LOCATION <u>N 5029739.4; E 367265.3 NAD 83 MTM ZONE 9 (LAT. 45.404814; LONG. -75.702048)</u>	ORIGINATED BY <u>DG</u>	
DIST <u>Eastern</u> HWY <u>417</u>	BOREHOLE TYPE <u>Portable Drill/Hydro-excavation</u>	COMPILED BY <u>ZS</u>	
DATUM <u>Geodetic</u>	DATE <u>July 20, 2017</u>	CHECKED BY <u>KCP</u>	

SOIL PROFILE		SAMPLES			GROUND WATER CONDITIONS	ELEVATION SCALE	DYNAMIC CONE PENETRATION RESISTANCE PLOT					PLASTIC NATURAL LIQUID LIMIT MOISTURE LIMIT CONTENT			UNIT WEIGHT γ kN/m ³	REMARKS & GRAIN SIZE DISTRIBUTION (%)		
ELEV DEPTH	DESCRIPTION	STRAT PLOT	NUMBER	TYPE			"N" VALUES	20	40	60	80	100	W _p	W			W _L	25
69.7	GROUND SURFACE																	
0.0 69.6	PORTLAND CEMENT CONCRETE (SIDEWALK)																	
0.1	(SP) Gravelly sand (FILL) Grey Moist		1	GRAB	-													
69.3 0.4	(SP) Sand (FILL) Brown Moist		2	GRAB	-													
68.6 1.1	END OF COREHOLE AT TOP OF FOOTING																	
	NOTES: 1. Corehole continued on Record of Drillhole 17-C17D.																	

GTA-MTO 001 N:\ACTIVE\SPATIAL_IMMTO\HWY417REHAB&WIDENING\02_DATA\GINT\1655214.GPJ GAL-GTA.GDT 6/6/19 JIM

+³, ×³: Numbers refer to Sensitivity ○ 3% STRAIN AT FAILURE

PROJECT <u>1655214-1130</u>	RECORD OF COREHOLE No 17-C18	SHEET 1 OF 1	METRIC
G.W.P. <u>4173-15-00</u>	LOCATION <u>N 5029742.5; E 367264.0 NAD 83 MTM ZONE 9 (LAT. 45.404842; LONG. -75.702064)</u>	ORIGINATED BY <u>DG</u>	
DIST <u>Eastern</u> HWY <u>417</u>	BOREHOLE TYPE <u>Portable Drill/Hydro-excavation</u>	COMPILED BY <u>ZS</u>	
DATUM <u>Geodetic</u>	DATE <u>July 20, 2017</u>	CHECKED BY <u>KCP</u>	

SOIL PROFILE		SAMPLES			GROUND WATER CONDITIONS	ELEVATION SCALE	DYNAMIC CONE PENETRATION RESISTANCE PLOT					PLASTIC NATURAL LIQUID LIMIT MOISTURE LIMIT CONTENT			UNIT WEIGHT γ kN/m ³	REMARKS & GRAIN SIZE DISTRIBUTION (%) GR SA SI CL
ELEV DEPTH	DESCRIPTION	STRAT PLOT	NUMBER	TYPE			"N" VALUES	SHEAR STRENGTH kPa					WATER CONTENT (%)			
							20	40	60	80	100	W _p	W	W _L		
							○ UNCONFINED	+ FIELD VANE				○ 3% STRAIN AT FAILURE				
							● QUICK TRIAXIAL	× REMOULDED				○ 3% STRAIN AT FAILURE				
							20	40	60	80	100	25	50	75		
69.6	GROUND SURFACE															
0.0	PORTLAND CEMENT CONCRETE (SIDEWALK)															
69.4																
0.2	(SP) Gravelly sand (FILL) Grey Moist		1	GRAB	-											
69.2																
0.4	(SP) Sand (FILL) Brown Moist															
68.4						69										
1.2	END OF COREHOLE AT TOP OF FOOTING															

GTA-MTO 001 N:\ACTIVE\SPATIAL_IMMTO\HWY417REHAB&WIDENING\02_DATA\GINT\1655214.GPJ GAL-GTA.GDT 6/6/19 JIM

+³, ×³: Numbers refer to Sensitivity ○ 3% STRAIN AT FAILURE

PROJECT <u>1655214-1130</u>	RECORD OF COREHOLE No 17-C19	SHEET 1 OF 1	METRIC
G.W.P. <u>4173-15-00</u>	LOCATION <u>N 5029745.3; E 367262.7 NAD 83 MTM ZONE 9 (LAT. 45.404867; LONG. -75.702081)</u>	ORIGINATED BY <u>DG</u>	
DIST <u>Eastern</u> HWY <u>417</u>	BOREHOLE TYPE <u>Portable Drill/Hydro-excavation</u>	COMPILED BY <u>ZS</u>	
DATUM <u>Geodetic</u>	DATE <u>July 20, 2017</u>	CHECKED BY <u>KCP</u>	

ELEV DEPTH	SOIL PROFILE DESCRIPTION	STRAT PLOT	SAMPLES			GROUND WATER CONDITIONS	ELEVATION SCALE	DYNAMIC CONE PENETRATION RESISTANCE PLOT					PLASTIC LIMIT W _p	NATURAL MOISTURE CONTENT W	LIQUID LIMIT W _L	UNIT WEIGHT γ kN/m ³	REMARKS & GRAIN SIZE DISTRIBUTION (%) GR SA SI CL
			NUMBER	TYPE	"N" VALUES			20	40	60	80	100					
69.6	GROUND SURFACE																
0.0	PORTLAND CEMENT CONCRETE (SIDEWALK)																
69.4	(SP) Gravelly sand (FILL) Grey Moist		1	GRAB	-												
69.2	(SP-SM) Sand, trace silt (FILL) Brown Moist																
68.4			2	GRAB	-		69										1 91 6 2
1.2	END OF COREHOLE AT TOP OF FOOTING NOTES: 1. Probable wood formwork encountered at 1.1 m below ground surface. 2. Corehole continued on Record of Drillhole 17-C19D.																

GTA-MTO 001 N:\ACTIVE\SPATIAL_IMMTO\HWY417REHAB&WIDENING\02_DATA\GINT\1655214.GPJ GAL-GTA.GDT 6/6/19 JIM

PROJECT <u>1655214-1130</u>	RECORD OF COREHOLE No 17-C20	SHEET 1 OF 1	METRIC
G.W.P. <u>4173-15-00</u>	LOCATION <u>N 5029748.4; E 367261.6 NAD 83 MTM ZONE 9 (LAT. 45.404895; LONG. -75.702094)</u>	ORIGINATED BY <u>DG</u>	
DIST <u>Eastern</u> HWY <u>417</u>	BOREHOLE TYPE <u>Portable Drill/Hydro-excavation</u>	COMPILED BY <u>ZS</u>	
DATUM <u>Geodetic</u>	DATE <u>July 19, 2017</u>	CHECKED BY <u>KCP</u>	

SOIL PROFILE		SAMPLES			GROUND WATER CONDITIONS	ELEVATION SCALE	DYNAMIC CONE PENETRATION RESISTANCE PLOT					PLASTIC NATURAL LIQUID LIMIT MOISTURE LIMIT CONTENT			UNIT WEIGHT γ kN/m ³	REMARKS & GRAIN SIZE DISTRIBUTION (%) GR SA SI CL		
ELEV DEPTH	DESCRIPTION	STRAT PLOT	NUMBER	TYPE			"N" VALUES	20	40	60	80	100	W _p	W			W _L	25
69.6	GROUND SURFACE																	
0.0 69.5	PORTLAND CEMENT CONCRETE (SIDEWALK)																	
0.1	(SP) Gravelly Sand (FILL) Brown Moist		1	GRAB	-													
69.2 0.4	(SP) Sand (FILL) Brown Moist		2	GRAB	-													
68.5 1.1	END OF COREHOLE																	
	NOTES: 1. Refusal to hydro-excavation on probable wood formwork encountered at 1.1 m below ground surface.																	

GTA-MTO 001 N:\ACTIVE\SPATIAL_IMMTO\HWY417REHAB&WIDENING\02_DATA\GINT\1655214.GPJ GAL-GTA.GDT 6/6/19 JIM

+³, ×³: Numbers refer to Sensitivity ○ 3% STRAIN AT FAILURE

PROJECT <u>1655214-1130</u>	RECORD OF COREHOLE No 17-C23	SHEET 1 OF 1	METRIC
G.W.P. <u>4173-15-00</u>	LOCATION <u>N 5029756.8; E 367258.0 NAD 83 MTM ZONE 9 (LAT. 45.404971; LONG. -75.702139)</u>	ORIGINATED BY <u>DG</u>	
DIST <u>Eastern</u> HWY <u>417</u>	BOREHOLE TYPE <u>Portable Drill/Hydro-excavation</u>	COMPILED BY <u>ZS</u>	
DATUM <u>Geodetic</u>	DATE <u>July 19, 2017</u>	CHECKED BY <u>KCP</u>	

SOIL PROFILE		SAMPLES			GROUND WATER CONDITIONS	ELEVATION SCALE	DYNAMIC CONE PENETRATION RESISTANCE PLOT					PLASTIC NATURAL LIQUID LIMIT MOISTURE LIMIT CONTENT			UNIT WEIGHT γ kN/m ³	REMARKS & GRAIN SIZE DISTRIBUTION (%)		
ELEV DEPTH	DESCRIPTION	STRAT PLOT	NUMBER	TYPE			"N" VALUES	20	40	60	80	100	W _p	W			W _L	25
69.5	GROUND SURFACE																	
0.0 69.4	PORTLAND CEMENT CONCRETE (SIDEWALK)																	
0.1	(SP) Gravelly sand (FILL) Grey Moist		1	GRAB	-													
69.1 0.4	(SP) Sand (FILL) Brown Moist																	
68.5 1.0	END OF COREHOLE NOTES: 1. Refusal to hydro-excavation on probable wood formwork encountered at 1.0 m below ground surface.																	

GTA-MTO 001 N:\ACTIVE\SPATIAL_IMMTO\HWY417REHAB&WIDENING02_DATA\GINT\1655214.GPJ GAL-GTA.GDT 6/6/19 JIM

PROJECT <u>1655214-1130</u>	RECORD OF COREHOLE No 17-C24	SHEET 1 OF 1	METRIC
G.W.P. <u>4173-15-00</u>	LOCATION <u>N 5029759.8; E 367256.8 NAD 83 MTM ZONE 9 (LAT. 45.404998; LONG. -75.702154)</u>	ORIGINATED BY <u>DG</u>	
DIST <u>Eastern</u> HWY <u>417</u>	BOREHOLE TYPE <u>Portable Drill/Hydro-excavation</u>	COMPILED BY <u>ZS</u>	
DATUM <u>Geodetic</u>	DATE <u>July 19, 2017</u>	CHECKED BY <u>KCP</u>	

SOIL PROFILE		SAMPLES			GROUND WATER CONDITIONS	ELEVATION SCALE	DYNAMIC CONE PENETRATION RESISTANCE PLOT					PLASTIC NATURAL LIQUID LIMIT MOISTURE LIMIT CONTENT			UNIT WEIGHT γ kN/m ³	REMARKS & GRAIN SIZE DISTRIBUTION (%)		
ELEV DEPTH	DESCRIPTION	STRAT PLOT	NUMBER	TYPE			"N" VALUES	20	40	60	80	100	W _p	W			W _L	25
69.5	GROUND SURFACE																	
0.0 69.4	PORTLAND CEMENT CONCRETE (SIDEWALK)																	
0.1	(SP) Gravelly Sand (FILL) Grey Moist		1	GRAB	-													
69.1 0.5	(SP) Sand (FILL) Brown Moist		2	GRAB	-													
68.5 1.0	END OF COREHOLE AT TOP OF FOOTING NOTES: 1. Probable wood formwork encountered at 1.0 m below ground surface. 2. Corehole continued on Record of Drillhole 17-C24D.																	

GTA-MTO 001 N:\ACTIVE\SPATIAL_IMMTO\HWY417REHAB&WIDENING02_DATA\GINT\1655214.GPJ GAL-GTA.GDT 6/6/19 JIM

+³, ×³: Numbers refer to Sensitivity ○ 3% STRAIN AT FAILURE

PROJECT <u>1655214-1130</u>	RECORD OF BOREHOLE No 17-131	SHEET 1 OF 2	METRIC
G.W.P. <u>4173-15-00</u>	LOCATION <u>N 5029723.5; E 367276.0 NAD 83 MTM ZONE 9 (LAT. 45.404670; LONG. -75.701913)</u>	ORIGINATED BY <u>PAH</u>	
DIST <u>Eastern</u> HWY <u>417</u>	BOREHOLE TYPE <u>Hydro-excavation/NQ Core</u>	COMPILED BY <u>ZS</u>	
DATUM <u>Geodetic</u>	DATE <u>August 7, 2017</u>	CHECKED BY <u>KCP</u>	

ELEV DEPTH	SOIL PROFILE DESCRIPTION	STRAT PLOT	SAMPLES			GROUND WATER CONDITIONS	ELEVATION SCALE	DYNAMIC CONE PENETRATION RESISTANCE PLOT					PLASTIC LIMIT W _p	NATURAL MOISTURE CONTENT W	LIQUID LIMIT W _L	UNIT WEIGHT γ kN/m ³	REMARKS & GRAIN SIZE DISTRIBUTION (%) GR SA SI CL
			NUMBER	TYPE	"N" VALUES			20	40	60	80	100					
70.0	GROUND SURFACE																
0.0	ASPHALTIC CONCRETE																
69.6	PORTLAND CEMENT CONCRETE																
0.5	(SP-SM) Gravelly sand (FILL) Grey																
69.1	(SP-SM) Sand, trace silt (FILL) Brown		1	GRAB	-												1 91 6 2
0.9	(SM/GMP) Sand and gravel, some silt, contains limestone fragments, cobbles and boulders Brown Moist						69										
68.2	Limestone (BEDROCK)																
1.8	Bedrock cored from depths 1.8 m to 4.9 m For bedrock coring details refer to Record of Drillhole 17-131		C1	RC	REC 98%		68										RQD = 56%
			C2	RC	REC 100%		67										RQD = 100%
			C3	RC	REC 100%		66										RQD = 100%
65.1	END OF BOREHOLE																
4.9																	

GTA-MTO 001 N:\ACTIVE\SPATIAL_IMMTO\HWY417REHAB&WIDENING02_DATA\GINT\1655214.GPJ GAL-GTA.GDT 6/6/19 JIM

PROJECT <u>1655214-1130</u>	RECORD OF BOREHOLE No 17-132	SHEET 1 OF 2	METRIC
G.W.P. <u>4173-15-00</u>	LOCATION <u>N 5029729.5; E 367290.4 NAD 83 MTM ZONE 9 (LAT. 45.404722; LONG. -75.701729)</u>	ORIGINATED BY <u>PAH</u>	
DIST <u>Eastern</u> HWY <u>417</u>	BOREHOLE TYPE <u>Wash Boring, NW Casing/NQ Core</u>	COMPILED BY <u>ZS</u>	
DATUM <u>Geodetic</u>	DATE <u>August 3 to 4, 2017</u>	CHECKED BY <u>KCP</u>	

ELEV DEPTH	SOIL PROFILE DESCRIPTION	STRAT PLOT	SAMPLES			GROUND WATER CONDITIONS	ELEVATION SCALE	DYNAMIC CONE PENETRATION RESISTANCE PLOT					PLASTIC LIMIT W _p	NATURAL MOISTURE CONTENT W	LIQUID LIMIT W _L	UNIT WEIGHT γ kN/m ³	REMARKS & GRAIN SIZE DISTRIBUTION (%) GR SA SI CL
			NUMBER	TYPE	"N" VALUES			SHEAR STRENGTH kPa									
							20	40	60	80	100						
70.1	GROUND SURFACE																
0.0	ASPHALTIC CONCRETE						70										
69.8	PORTLAND CEMENT CONCRETE																
69.6	(SP) Gravelly sand (FILL) Grey Moist		1	SS	55												
69.1	(SP) Sand, trace gravel (FILL) Dense Brown Moist		2	SS	93		69										
68.2	(SM) Gravelly Silty SAND, contains cobbles (TILL) Very dense Brown Moist to wet		3	SS	50/0.08												
68.2	Limestone (BEDROCK)						68									RQD = 100%	
	Bedrock cored from depths 1.9 m to 5.3 m For bedrock coring details refer to Record of Drillhole 17-132		C1	RC	REC 100%												
			C2	RC	REC 100%		67									RQD = 96%	
			C3	RC	REC 100%		66									RQD = 97%	
64.8	END OF BOREHOLE						65										
5.3																	

GTA-MTO 001 N:\ACTIVE\SPATIAL_IMMTO\HWY417REHAB&WIDENING02_DATA\GINT\1655214.GPJ GAL-GTA.GDT 6/6/19 JIM

+³, ×³: Numbers refer to Sensitivity ○ 3% STRAIN AT FAILURE

PROJECT <u>1655214-1130</u>	RECORD OF BOREHOLE No 17-133	SHEET 1 OF 2	METRIC
G.W.P. <u>4173-15-00</u>	LOCATION <u>N 5029764.9; E 367258.1 NAD 83 MTM ZONE 9 (LAT. 45.405044; LONG. -75.702136)</u>	ORIGINATED BY <u>PAH</u>	
DIST <u>Eastern</u> HWY <u>417</u>	BOREHOLE TYPE <u>Wash Boring, NW Casing/NQ Core</u>	COMPILED BY <u>ZS</u>	
DATUM <u>Geodetic</u>	DATE <u>August 7 to 8 2017</u>	CHECKED BY <u>KCP</u>	

ELEV DEPTH	SOIL PROFILE DESCRIPTION	STRAT PLOT	SAMPLES			GROUND WATER CONDITIONS	ELEVATION SCALE	DYNAMIC CONE PENETRATION RESISTANCE PLOT					PLASTIC LIMIT W _p	NATURAL MOISTURE CONTENT W	LIQUID LIMIT W _L	UNIT WEIGHT γ kN/m ³	REMARKS & GRAIN SIZE DISTRIBUTION (%) GR SA SI CL
			NUMBER	TYPE	"N" VALUES			SHEAR STRENGTH kPa									
								20	40	60	80	100					
69.4	GROUND SURFACE																
0.0	ASPHALTIC CONCRETE																
69.0	PORTLAND CEMENT CONCRETE																
0.5	(SP) Gravelly sand (FILL) Grey		1	SS	33		69										9 76 12 3
68.5	(SM) Sand, some gravel and silt (FILL) Dense Brown Moist		2	SS	50/0.15												
1.1	(SP/GP) Sand and gravel (FILL) Grey brown Wet						68										
	Limestone (BEDROCK)		C1	RC	REC 100%		67										RQD = 84%
	Bedrock cored from depths 1.1 m to 4.1 m For bedrock coring details refer to Record of Drillhole 17-133		C2	RC	REC 100%		66										RQD = 100%
65.3																	
4.1	END OF BOREHOLE																

GTA-MTO 001 N:\ACTIVE\SPATIAL_IMMTO\HWY417REHAB&WIDENING02_DATA\GINT\1655214.GPJ GAL-GTA.GDT 6/6/19 JIM

PROJECT 1655214-1130	RECORD OF BOREHOLE No 17-134	SHEET 1 OF 2	METRIC
G.W.P. 4173-15-00	LOCATION N 5029772.1; E 367272.0 NAD 83 MTM ZONE 9 (LAT. 45.405108; LONG. -75.701958)	ORIGINATED BY PAH	
DIST Eastern HWY 417	BOREHOLE TYPE Portable Drill/NQ Core	COMPILED BY ZS	
DATUM Geodetic	DATE August 1 and 3, 2017	CHECKED BY KCP	

ELEV DEPTH	SOIL PROFILE DESCRIPTION	STRAT PLOT	SAMPLES			GROUND WATER CONDITIONS	ELEVATION SCALE	DYNAMIC CONE PENETRATION RESISTANCE PLOT					UNIT WEIGHT γ kN/m ³	REMARKS & GRAIN SIZE DISTRIBUTION (%) GR SA SI CL
			NUMBER	TYPE	"N" VALUES			SHEAR STRENGTH kPa						
								20 40 60 80 100	20 40 60 80 100	W _p W W _L	25 50 75			
69.3	GROUND SURFACE													
0.0	ASPHALTIC CONCRETE													
69.0	PORTLAND CEMENT CONCRETE													
68.8	(SP) Gravelly sand (FILL) Grey		1	SS	51									
0.5	(SP) Sand, trace gravel (FILL) Very dense to compact Brown Moist		2	SS	15									
67.6			3	SS	150/0.15									
1.9	(GM) Sandy gravel, some silt (FILL) Grey brown Limestone (BEDROCK)		C1	RC	REC 100%								RQD = 68%	
	Bedrock cored from depths 1.9 m to 5.8 m		C2	RC	REC 100%								RQD = 100%	
	For bedrock coring details refer to Record of Drillhole 17-134		C3	RC	REC 100%								RQD = 100%	
63.5	END OF BOREHOLE													
5.8	NOTES: 1. Water level in well screen at a depth of 1.5 m below ground surface (Elev. 67.8 m), measured on August 23, 2017.													

GTA-MTO 001 N:\ACTIVE\SPATIAL_IMMTO\HWY417REHAB&WIDENING\02_DATA\GINT\1655214.GPJ GAL-GTA.GDT 6/6/19 JIM

+³, ×³: Numbers refer to Sensitivity ○ 3% STRAIN AT FAILURE

PROJECT <u>1655214-1130</u>	RECORD OF BOREHOLE No 18-1301	SHEET 1 OF 2	METRIC
G.W.P. <u>4173-15-00</u>	LOCATION <u>N 5029759.9; E 367250.0 NAD 83 MTM ZONE 9 (LAT. 45.404990; LONG. -75.702240)</u>	ORIGINATED BY <u>RI</u>	
DIST <u>Eastern</u> HWY <u>417</u>	BOREHOLE TYPE <u>Portable Rotary Drill, BW Casing/AW Rod</u>	COMPILED BY <u>ZS</u>	
DATUM <u>Geodetic</u>	DATE <u>November 20 to 21, 2018</u>	CHECKED BY <u>KCP</u>	

ELEV DEPTH	SOIL PROFILE DESCRIPTION	STRAT PLOT	SAMPLES			GROUND WATER CONDITIONS	ELEVATION SCALE	DYNAMIC CONE PENETRATION RESISTANCE PLOT					PLASTIC LIMIT W _p	NATURAL MOISTURE CONTENT W	LIQUID LIMIT W _L	UNIT WEIGHT γ kN/m ³	REMARKS & GRAIN SIZE DISTRIBUTION (%) GR SA SI CL
			NUMBER	TYPE	"N" VALUES			SHEAR STRENGTH kPa									
							20	40	60	80	100						
71.6	GROUND SURFACE																
0.0	(SM) Silty sand, contains organic matter (rootlets) (TOPSOIL)																
71.2	Very loose																
0.4	Brown Moist		1	SS	4												
	(SP-SM) Sand, trace gravel, contains thin seams of silty sand (FILL)		2	SS	7		71										
	Brown Moist		3	SS	7											5 84 (11)	
			4	SS	3		70										
69.3	CONCRETE (FOOTING)		1A	RC	-		69										
2.4																	
67.9	Limestone (BEDROCK)		1B	RC	REC 95%		68									RQD = 76%	
3.7	Bedrock cored from depths 3.7 m to 5.5 m																
	For bedrock coring details refer to Record of Drillhole 18-1301		2	RC	REC 100%		67									RQD = 97%	
66.1	END OF BOREHOLE																
5.5																	
	NOTES: 1. Manual third weight hammer used for all split spoon samples. "N" values are not representative of ASTM D1586 SPT N values and should be interpreted in consideration of their reduced energy.																

GTA-MTO 001 N:\ACTIVE\SPATIAL_IMMTO\HWY417REHAB&WIDENING\02_DATA\GINT\1655214.GPJ GAL-GTA.GDT 6/6/19 JIM

+³, ×³: Numbers refer to Sensitivity ○ 3% STRAIN AT FAILURE

PROJECT 1655214-1130 **RECORD OF BOREHOLE No 18-1302** SHEET 1 OF 2 **METRIC**
G.W.P. 4173-15-00 **LOCATION** N 5029724.1; E 367265.0 NAD 83 MTM ZONE 9 (LAT. 45.404670; LONG. -75.702050) **ORIGINATED BY** RI
DIST Eastern **HWY** 417 **BOREHOLE TYPE** Portable Rotary Drill, BW Casing **COMPILED BY** ZS
DATUM Geodetic **DATE** November 21 and 22, 2018 **CHECKED BY** KCP

SOIL PROFILE		SAMPLES			GROUND WATER CONDITIONS	ELEVATION SCALE	DYNAMIC CONE PENETRATION RESISTANCE PLOT					PLASTIC LIMIT W _p	NATURAL MOISTURE CONTENT W	LIQUID LIMIT W _L	UNIT WEIGHT γ	REMARKS & GRAIN SIZE DISTRIBUTION (%)								
ELEV DEPTH	DESCRIPTION	STRAT PLOT	NUMBER	TYPE			"N" VALUES	SHEAR STRENGTH kPa									WATER CONTENT (%)							
						20	40	60	80	100	20	40	60	80	100	25	50	75		GR	SA	SI	CL	
72.3	GROUND SURFACE																							
0.0	(SM) SILTY SAND, contains organic matter (rootlets) (TOPSOIL)		1	SS	4																			
71.9	Dark brown Moist																							
0.4	(SP) SAND (FILL)		2	SS	6																			
71.2	Brown Moist																							
1.1	(SM) Silty sand, some gravel, contains brick, mortar and concrete (FILL)		3	SS	33																			
	Dark brown Moist		4	SS	37																			
69.5	Weathered CONCRETE		5	SS	17																			
2.8	PORTLAND CEMENT CONCRETE (FOOTING)		1	RC	-																			
69.1			2	RC	-																			
3.2	Limestone (BEDROCK)		3	RC	REC 100%																			
67.9	Bedrock cored from depths 4.4 m to 6.5 m		4	RC	REC 100%																			
4.4	For bedrock coring details refer to Record of Drillhole 18-1302																							
65.8	END OF BOREHOLE																							
6.5	NOTES: 1. Manual third weight hammer used for all split spoon samples. "N" values are not representative of ASTM D1586 SPT N values and should be interpreted in consideration of their reduced energy.																							

GTA-MTO 001 N:\ACTIVE\SPATIAL_IMMTO\HWY417REHAB&WIDENING\02_DATA\GINT\1655214.GPJ GAL-GTA.GDT 6/6/19 JIM

+³, ×³: Numbers refer to Sensitivity ○ 3% STRAIN AT FAILURE

PROJECT <u>1655214-1130</u>	RECORD OF BOREHOLE No 18-1303	SHEET 1 OF 2	METRIC
G.W.P. <u>4173-15-00</u>	LOCATION <u>N 5029772.9; E 367281.5 NAD 83 MTM ZONE 9 (LAT. 45.405100; LONG. -75.701830)</u>	ORIGINATED BY <u>RI</u>	
DIST <u>Eastern</u> HWY <u>417</u>	BOREHOLE TYPE <u>Portable Rotary Drill, BW Casing</u>	COMPILED BY <u>ZS</u>	
DATUM <u>Geodetic</u>	DATE <u>November 18 and 19, 2018</u>	CHECKED BY <u>KCP</u>	

SOIL PROFILE		SAMPLES			GROUND WATER CONDITIONS	ELEVATION SCALE	DYNAMIC CONE PENETRATION RESISTANCE PLOT					PLASTIC LIMIT W _p	NATURAL MOISTURE CONTENT W	LIQUID LIMIT W _L	UNIT WEIGHT γ	REMARKS & GRAIN SIZE DISTRIBUTION (%)		
ELEV DEPTH	DESCRIPTION	STRAT PLOT	NUMBER	TYPE			"N" VALUES	SHEAR STRENGTH kPa									WATER CONTENT (%)	
						20	40	60	80	100				25	50	75		GR SA SI CL
69.5	GROUND SURFACE																	
0.0	ASPHALTIC CONCRETE																	
69.3	(SW) Gravelly sand, angular (FILL)		1	SS	25													
0.3	Grey (SW) Sand, fine to coarse, trace gravel (FILL) Loose to compact Brown Moist		2	SS	167/0.28													
68.4	CONCRETE (FOOTING)		1	RC	-													
1.1			2A	RC	-													
67.0	Limestone (BEDROCK)		2B	RC	-													
2.5	Bedrock cored from depths 2.5 m to 4.5 m For bedrock coring details refer to Record of Drillhole 18-1303		3	RC	REC 100%													RQD = 93%
65.0			4	RC	REC 100%													RQD = 100%
4.5	END OF BOREHOLE																	
	NOTES: 1. Manual third weight hammer used for all split spoon samples. "N" values are not representative of ASTM D1586 SPT N values and should be interpreted in consideration of their reduced energy. 2. Water level in open borehole at 1.7 m depth below ground surface (Elev. 67.8 m), upon completion of drilling.																	

GTA-MTO 001 N:\ACTIVE\SPATIAL_IMMTO\HWY417\REHAB&WIDENING\02_DATA\GINT\1655214.GPJ GAL-GTA.GDT 6/6/19 JIM

PROJECT <u>1655214-1130</u>	RECORD OF BOREHOLE No 18-1304	SHEET 1 OF 2	METRIC
G.W.P. <u>4173-15-00</u>	LOCATION <u>N 5029737.0; E 367296.7 NAD 83 MTM ZONE 9 (LAT. 45.404780; LONG. -75.701640)</u>	ORIGINATED BY <u>RI</u>	
DIST <u>Eastern</u> HWY <u>417</u>	BOREHOLE TYPE <u>Portable Rotary Drill, BW Casing</u>	COMPILED BY <u>ZS</u>	
DATUM <u>Geodetic</u>	DATE <u>November 18 and 19, 2018</u>	CHECKED BY <u>KCP</u>	

ELEV DEPTH	SOIL PROFILE DESCRIPTION	STRAT PLOT	SAMPLES			GROUND WATER CONDITIONS	ELEVATION SCALE	DYNAMIC CONE PENETRATION RESISTANCE PLOT					PLASTIC LIMIT W _p	NATURAL MOISTURE CONTENT W	LIQUID LIMIT W _L	UNIT WEIGHT γ kN/m ³	REMARKS & GRAIN SIZE DISTRIBUTION (%) GR SA SI CL
			NUMBER	TYPE	"N" VALUES			SHEAR STRENGTH kPa									
								20	40	60	80	100					
69.7	GROUND SURFACE																
0.0	(SM) Silty sand, contains organic matter (rootlets) (TOPSOIL)																
0.1	Dark brown Moist		1	SS	25												
69.0	(SW) Sand, trace gravel (FILL)		2	SS	50/0.10		69										
0.7	Loose Brown Moist																
	PORTLAND CEMENT CONCRETE (FOOTING)		1	RC	-												
			2A	RC	-		68										
67.9	Limestone (BEDROCK)																
1.8	Bedrock cored from depths 1.8 m to 3.8 m		2B	RC	REC 100%		67										RQD = 51%
	For bedrock coring details refer to Record of Drillhole 18-1304																
			3	RC	REC 100%		66										
65.9	END OF BOREHOLE																
3.8	NOTES: 1. Manual third weight hammer used for all split spoon samples. "N" values are not representative of ASTM D1586 SPT N values and should be interpreted in consideration of their reduced energy.																

GTA-MTO 001 N:\ACTIVE\SPATIAL_IMMTO\HWY417REHAB&WIDENING\02_DATA\GINT\1655214.GPJ GAL-GTA.GDT 6/6/19 JIM

+³, ×³: Numbers refer to Sensitivity ○ 3% STRAIN AT FAILURE

PROJECT <u>1655214-1130</u>	RECORD OF BOREHOLE No 18-1306	SHEET 1 OF 1	METRIC
G.W.P. <u>4173-15-00</u>	LOCATION <u>N 5029727.0; E 367259.4 NAD 83 MTM ZONE 9 (LAT. 45.404690; LONG. -75.702120)</u>	ORIGINATED BY <u>RI</u>	
DIST <u>Eastern</u> HWY <u>417</u>	BOREHOLE TYPE <u>Power Auger, 200 mm Diam. (Hollow Stem)</u>	COMPILED BY <u>ZS</u>	
DATUM <u>Geodetic</u>	DATE <u>October 16-17, 2018</u>	CHECKED BY <u>KCP</u>	

ELEV DEPTH	SOIL PROFILE DESCRIPTION	STRAT PLOT	SAMPLES			GROUND WATER CONDITIONS	ELEVATION SCALE	DYNAMIC CONE PENETRATION RESISTANCE PLOT					PLASTIC LIMIT W _p	NATURAL MOISTURE CONTENT W	LIQUID LIMIT W _L	UNIT WEIGHT γ	REMARKS & GRAIN SIZE DISTRIBUTION (%)				
			NUMBER	TYPE	"N" VALUES			SHEAR STRENGTH kPa										WATER CONTENT (%)			
								20	40	60	80	100						GR	SA	SI	CL
76.0	GROUND SURFACE																				
0.0	ASPHALTIC CONCRETE																				
75.6	CONCRETE																				
0.4	(SW) Sand and gravel, angular (FILL)		1	GS	-																
75.3	Grey Moist		2	GS	-																
0.7	(SW/SP) Gravelly sand, angular (FILL)		3	SS	39		75														
	Dense to very dense Grey brown Moist		4	SS	75		74														
73.9	(SP) Sand, trace silt and gravel (FILL)		5	SS	38		73														
2.1	Dense to compact Brown Moist		6	SS	46		72														
			7	SS	29		71														3 90 (7)
			8	SS	19																
70.7	(SM) Gravelly SAND, some silt and clay, contains organic matter (TILL)		9	SS	6																
5.3	Loose Brown to dark brown Moist to wet		10	SS	50/0.28																
69.5	END OF BOREHOLE AUGER REFUSAL on inferred bedrock																				
6.6	NOTES: 1. Borehole dry upon completion of drilling.																				

GTA-MTO 001 N:\ACTIVE\SPATIAL_IMMTO\HWY417REHAB&WIDENING02_DATA\GINT\1655214.GPJ GAL-GTA.GDT 6/6/19 JIM

+³, ×³: Numbers refer to Sensitivity ○ 3% STRAIN AT FAILURE

PROJECT 1655214-1130 **RECORD OF BOREHOLE No 18-1307** SHEET 1 OF 1 **METRIC**
G.W.P. 4173-15-00 **LOCATION** N 5029771.2; E 367290.2 NAD 83 MTM ZONE 9 (LAT. 45.405090; LONG. -75.701720) **ORIGINATED BY** RI
DIST Eastern **HWY** 417 **BOREHOLE TYPE** Power Auger, 200 mm Diam. (Hollow Stem) **COMPILED BY** ZS
DATUM Geodetic **DATE** October 15-16, 2018 **CHECKED BY** KCP

SOIL PROFILE		SAMPLES			GROUND WATER CONDITIONS	ELEVATION SCALE	DYNAMIC CONE PENETRATION RESISTANCE PLOT					PLASTIC LIMIT W _p	NATURAL MOISTURE CONTENT W	LIQUID LIMIT W _L	UNIT WEIGHT γ	REMARKS & GRAIN SIZE DISTRIBUTION (%)		
ELEV DEPTH	DESCRIPTION	STRAT PLOT	NUMBER	TYPE			"N" VALUES	20	40	60	80						100	25
75.5	GROUND SURFACE																	
0.0	ASPHALTIC CONCRETE																	
0.1	CONCRETE																	
74.9																		
0.6	(SM) Sand, some silt, some gravel (FILL) Very dense Grey Moist		1	GS	-													
			2	SS	59													
			3	SS	52													7 76 (17)
			4	SS	85													
72.9	(SP-SM) Sand, some silt (FILL) Very dense to compact Brown		5	SS	59													
2.6			6	SS	42													0 88 (12)
			7	SS	61													
			8	SS	36													
			9	SS	15													
68.8	(SM) Silty sand, contains organic matter and ash (FILL) Compact Dark brown to black Moist																	
6.7																		
68.2	(SM) Gravelly Silty SAND (TILL) Compact Grey Moist to wet		10	SS	13													
7.3																		
67.8	END OF BOREHOLE SAMPLER REFUSAL																	
7.7	NOTES: 1. Borehole dry upon completion of drilling.																	

GTA-MTO 001 N:\ACTIVE\SPATIAL_IMMTO\HWY417\REHAB&WIDENING\02_DATA\GINT\1655214.GPJ GAL-GTA.GDT 6/6/19 JIM

+³, ×³: Numbers refer to Sensitivity ○ 3% STRAIN AT FAILURE

PROJECT <u>1655214-1130</u>	RECORD OF BOREHOLE No 18-1308	SHEET 1 OF 1	METRIC
G.W.P. <u>4173-15-00</u>	LOCATION <u>N 5029754.4; E 367294.6 NAD 83 MTM ZONE 9 (LAT. 45.404940; LONG. -75.701670)</u>	ORIGINATED BY <u>DJG</u>	
DIST <u>Eastern</u> HWY <u>417</u>	BOREHOLE TYPE <u>Power Auger, 200 mm Diam. (Hollow Stem)</u>	COMPILED BY <u>ZS</u>	
DATUM <u>Geodetic</u>	DATE <u>October 3, 2018</u>	CHECKED BY <u>KCP</u>	

SOIL PROFILE		SAMPLES			GROUND WATER CONDITIONS	ELEVATION SCALE	DYNAMIC CONE PENETRATION RESISTANCE PLOT					PLASTIC LIMIT W _p	NATURAL MOISTURE CONTENT W	LIQUID LIMIT W _L	UNIT WEIGHT γ	REMARKS & GRAIN SIZE DISTRIBUTION (%)								
ELEV DEPTH	DESCRIPTION	STRAT PLOT	NUMBER	TYPE			"N" VALUES	SHEAR STRENGTH kPa									WATER CONTENT (%)							
						20	40	60	80	100	20	40	60	80	100	25	50	75		GR	SA	SI	CL	
75.8	GROUND SURFACE																							
0.0	ASPHALTIC CONCRETE																							
75.5	(SP) Sand and gravel, angular (FILL) Grey		1	GS	-																			
75.0	(SP) Gravelly sand (FILL) Dense to very dense Grey Moist		2	SS	35																			
			3	SS	81																			
			4	SS	64																			
72.7	(SP-SM) Sand, trace silt, trace gravel (FILL) Dense to very dense Brown Moist		5	SS	58																			
			6	SS	48																			
			7	SS	58																			
70.5	(SP-SM) Sand, some silt and gravel (FILL) Dense Grey brown to black Moist		8	SS	44																			
			9	SS	41																			
68.9	(SM) SILTY SAND, some gravel and clay (TILL) Compact Grey brown Moist		10	SS	15																			
			11	SS	27																			
67.5	END OF BOREHOLE AUGER REFUSAL																							
8.3	NOTES: 1. Borehole dry upon completion of drilling.																							

GTA-MTO 001 N:\ACTIVE\SPATIAL_IMMTO\HWY417REHAB&WIDENING\02_DATA\GINT\1655214.GPJ GAL-GTA.GDT 6/6/19 JIM

+³, ×³: Numbers refer to Sensitivity ○ 3% STRAIN AT FAILURE

PROJECT <u>1655214-1130</u>	RECORD OF BOREHOLE No 18-1309	SHEET 1 OF 1	METRIC
G.W.P. <u>4173-15-00</u>	LOCATION <u>N 5029734.2; E 367312.9 NAD 83 MTM ZONE 9 (LAT. 45.404750; LONG. -75.701440)</u>	ORIGINATED BY <u>KM</u>	
DIST <u>Eastern</u> HWY <u>417</u>	BOREHOLE TYPE <u>Power Auger, 200 mm Diam. (Hollow Stem)</u>	COMPILED BY <u>ZS</u>	
DATUM <u>Geodetic</u>	DATE <u>November 7, 2018</u>	CHECKED BY <u>KCP</u>	

SOIL PROFILE		SAMPLES			GROUND WATER CONDITIONS	ELEVATION SCALE	DYNAMIC CONE PENETRATION RESISTANCE PLOT					PLASTIC LIMIT W _p	NATURAL MOISTURE CONTENT W	LIQUID LIMIT W _L	UNIT WEIGHT γ	REMARKS & GRAIN SIZE DISTRIBUTION (%)								
ELEV DEPTH	DESCRIPTION	STRAT PLOT	NUMBER	TYPE			"N" VALUES	SHEAR STRENGTH kPa									WATER CONTENT (%)							
						20	40	60	80	100	20	40	60	80	100	25	50	75		GR	SA	SI	CL	
70.1	GROUND SURFACE																							
0.0	(SM) Gravelly silty sand (FILL) Compact Brown Moist		1	SS	10																			
69.8																								
0.3	(SM) Silty sand, contains cobbles (FILL) Compact Brown Moist																							
69.3																								
0.8	(SP) Gravelly sand, contains cobbles (FILL) Compact Brown Moist		2	SS	27																			
68.6																								
1.5	(SM/ML) Sand and silt, some gravel (FILL) Very loose Brown Moist		3	SS	2																			
67.4																								
2.7	(SM) Silty SAND, some gravel (TILL) Very loose to very dense Grey Moist		4	SS	3																			
66.9																								
3.2	END OF BOREHOLE AUGER REFUSAL		5	SS	50/0.03																			
	NOTES: 1. Water level in open borehole at 3.1 m depth below ground surface (Elev. 67.1 m), upon completion of drilling.																							

GTA-MTO 001 N:\ACTIVE\SPATIAL_IMMTO\HWY417\REHAB&WIDENING\02_DATA\GINT\1655214.GPJ GAL-GTA.GDT 6/6/19 JIM

+³, ×³: Numbers refer to Sensitivity ○ 3% STRAIN AT FAILURE

PROJECT 1655214-1130	RECORD OF BOREHOLE No 18-1310	SHEET 1 OF 1	METRIC
G.W.P. 4173-15-00	LOCATION N 5029707.8; E 367353.0 NAD 83 MTM ZONE 9 (LAT. 45.404510; LONG. -75.700930)	ORIGINATED BY KM	
DIST Eastern HWY 417	BOREHOLE TYPE Power Auger, 200 mm Diam. (Hollow Stem)	COMPILED BY ZS	
DATUM Geodetic	DATE November 8, 2018	CHECKED BY KCP	

SOIL PROFILE		SAMPLES			GROUND WATER CONDITIONS	ELEVATION SCALE	DYNAMIC CONE PENETRATION RESISTANCE PLOT					PLASTIC LIMIT W _p	NATURAL MOISTURE CONTENT W	LIQUID LIMIT W _L	UNIT WEIGHT γ	REMARKS & GRAIN SIZE DISTRIBUTION (%)
ELEV DEPTH	DESCRIPTION	STRAT PLOT	NUMBER	TYPE			"N" VALUES	SHEAR STRENGTH kPa								
						20 40 60 80 100	20 40 60 80 100									GR SA SI CL
71.9	GROUND SURFACE															
0.8	ASPHALTIC CONCRETE															
71.6	(SP) Gravelly sand (FILL)															
0.3	Brown Moist (SM) Sand, some gravel and silt, contains ash and cobbles (FILL) Loose Dark brown Moist		1	SS	6											
			2	SS	5											
			3	SS	8											9 74 (17)
68.9	(SP) Sand (FILL) Very loose Brown Moist		4	SS	2											
68.2	- Hydrocarbon odour detected (ML) Silt, some sand, trace gravel and clay (FILL) Very loose to compact Dark brown to black Wet		5	SS	1											
3.7	- Hydrocarbon odour detected															
67.0	(SM) Silty SAND, some gravel (TILL) Compact Grey Wet		6	SS	10											3 19 74 4
4.9	- Hydrocarbon odour detected		7	SS	10											
65.6	END OF BOREHOLE AUGER REFUSAL		8	SS	50/0.05											
6.3	NOTES: 1. Water level in well screen at a depth of 4.6 m below ground surface (Elev. 67.3 m), measured on December 6, 2018.															

GTA-MTO 001 N:\ACTIVE\SPATIAL_IMMTO\HWY417REHAB&WIDENING\02_DATA\GINT\1655214.GPJ GAL-GTA.GDT 6/6/19 JIM

+³, ×³: Numbers refer to Sensitivity ○ 3% STRAIN AT FAILURE

PROJECT <u>1655214-1130</u>	RECORD OF BOREHOLE No 18-1311	SHEET 1 OF 1	METRIC
G.W.P. <u>4173-15-00</u>	LOCATION <u>N 5029774.9; E 367417.2 NAD 83 MTM ZONE 9 (LAT. 45.405110; LONG. -75.700100)</u>	ORIGINATED BY <u>KM</u>	
DIST <u>Eastern</u> HWY <u>417</u>	BOREHOLE TYPE <u>Power Auger, 200 mm Diam. (Hollow Stem)</u>	COMPILED BY <u>ZS</u>	
DATUM <u>Geodetic</u>	DATE <u>November 7-8, 2018</u>	CHECKED BY <u>KCP</u>	

ELEV DEPTH	SOIL PROFILE DESCRIPTION	STRAT PLOT	SAMPLES			GROUND WATER CONDITIONS	ELEVATION SCALE	DYNAMIC CONE PENETRATION RESISTANCE PLOT					PLASTIC LIMIT W _p	NATURAL MOISTURE CONTENT W	LIQUID LIMIT W _L	UNIT WEIGHT γ kN/m ³	REMARKS & GRAIN SIZE DISTRIBUTION (%)					
			NUMBER	TYPE	"N" VALUES			SHEAR STRENGTH kPa														
								20	40	60	80	100						GR	SA	SI	CL	
70.1	GROUND SURFACE																					
0.0	ASPHALTIC CONCRETE																					
0.2	(SP) Gravelly SAND (FILL) Brown Moist		1	SS	14																	
	(SP) SAND, trace to some gravel (FILL) Compact Brown Moist		2	SS	33																	
68.6																						
1.5	(SM) Silty SAND Compact to loose Brown to grey Moist to wet		3	SS	11																	
			4	SS	4																	
			5	SS	8																	
			6	SS	8																	
			7	SS	15																	
64.8																						
5.3	(ML) SILT, some sand Compact Grey Wet		8	SS	11																	
63.9																						
6.3	(SM/GM) Silty SAND and GRAVEL (TILL) Compact to dense Grey Wet		9	SS	30																	
			10	SS	34																	
62.8																						
7.3	END OF BOREHOLE AUGER REFUSAL																					
	NOTES: 1. Water level in open borehole at 4.3 m depth below ground surface (Elev. 65.8 m), upon completion of drilling.																					

GTA-MTO 001 N:\ACTIVE\SPATIAL_IMMTO\HWY417\REHAB&WIDENING02_DATA\GINT\1655214.GPJ GAL-GTA.GDT 6/6/19 JIM

+³, ×³: Numbers refer to Sensitivity ○ 3% STRAIN AT FAILURE

CH 17-C01 (Dry)
Core Box 1 of 1

Elevation 68.45 m Top of Footing



Elevation 66.28 m EOH



Foundation Investigation
Highway 417 Overpass Structures at Bronson Avenue
Ottawa, Ontario

Project No.	1655214 / 1130
Drawn:	KS
Date:	2017-09-08
Review:	KCP

Figure A1

CH 17-C01 (Wet)
Core Box 1 of 1

Elevation 68.45 m Top of Footing

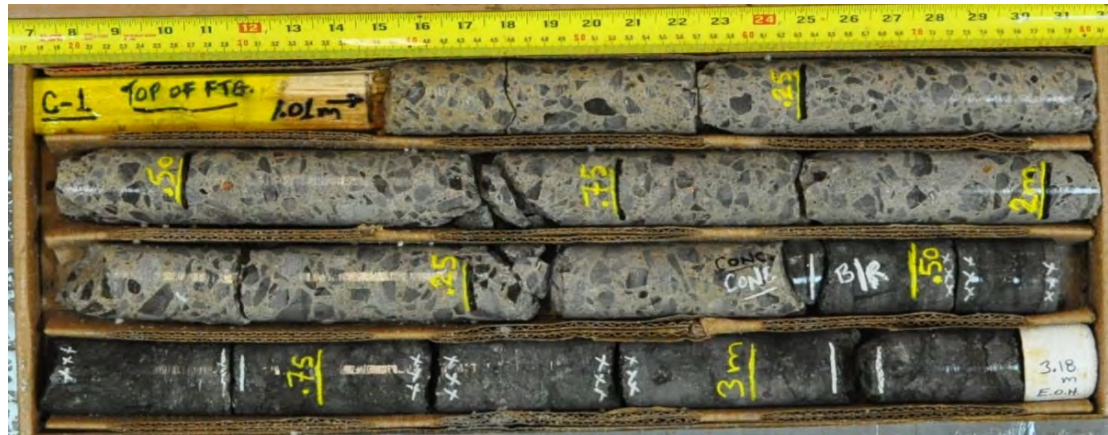

Elevation 66.28 m EOH



Foundation Investigation
Highway 417 Overpass Structures at Bronson Avenue
Ottawa, Ontario

Project No.	1655214 / 1130
Drawn:	KS
Date:	2017-09-08
Review:	KCP

Figure A2

CH 17-C04 (Dry)
Core Box 1 of 1

Elevation 68.43 m Top of Footing



Elevation 66.73 m EOH



Foundation Investigation
Highway 417 Overpass Structures at Bronson Avenue
Ottawa, Ontario

Project No.	1655214 / 1130
Drawn:	KS
Date:	2017-09-08
Review:	KCP

Figure A3

CH 17-C04 (Wet)
Core Box 1 of 1

Elevation 68.43 m Top of Footing

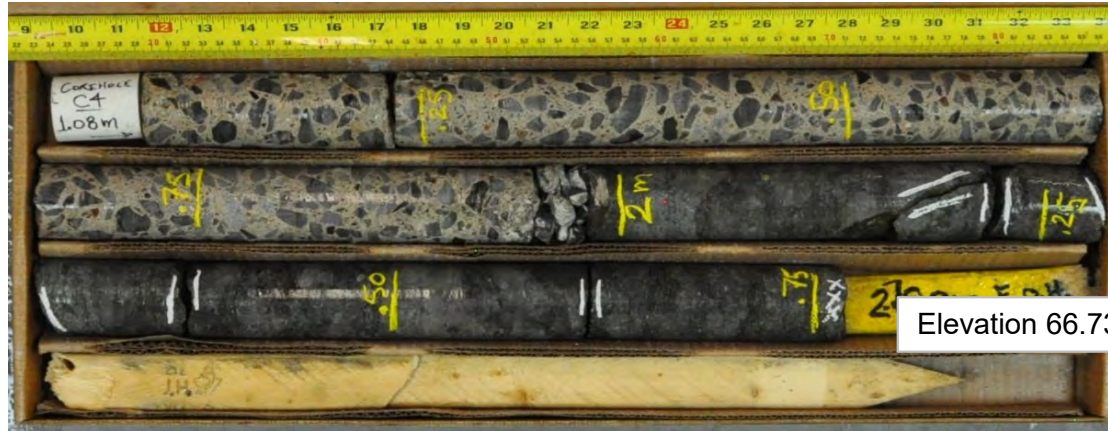

Elevation 66.73 m EOH



Foundation Investigation
Highway 417 Overpass Structures at Bronson Avenue
Ottawa, Ontario

Project No.	1655214 / 1130
Drawn:	KS
Date:	2017-09-08
Review:	KCP

Figure A4

CH 17-C09 (Dry)
Core Box 1 to 3 of 3

Elevation 68.72 m Top of Footing



Elevation 64.22 m EOH



Foundation Investigation
Highway 417 Overpass Structures at Bronson Avenue
Ottawa, Ontario

Project No.	1655214 / 1130
Drawn:	KS
Date:	2017-09-08
Review:	KCP

Figure A5

CH 17-C09 (Wet)
Core Box 1 of 3 of 3

Elevation 68.72 m Top of Footing



Elevation 64.22 m EOH



Foundation Investigation
Highway 417 Overpass Structures at Bronson Avenue
Ottawa, Ontario

Project No.	1655214 / 1130
Drawn:	KS
Date:	2017-09-08
Review:	KCP

Figure A6

CH 17-C11 (Dry)
Core Box 1 and 2 of 2

Elevation 68.86 m Top of Footing

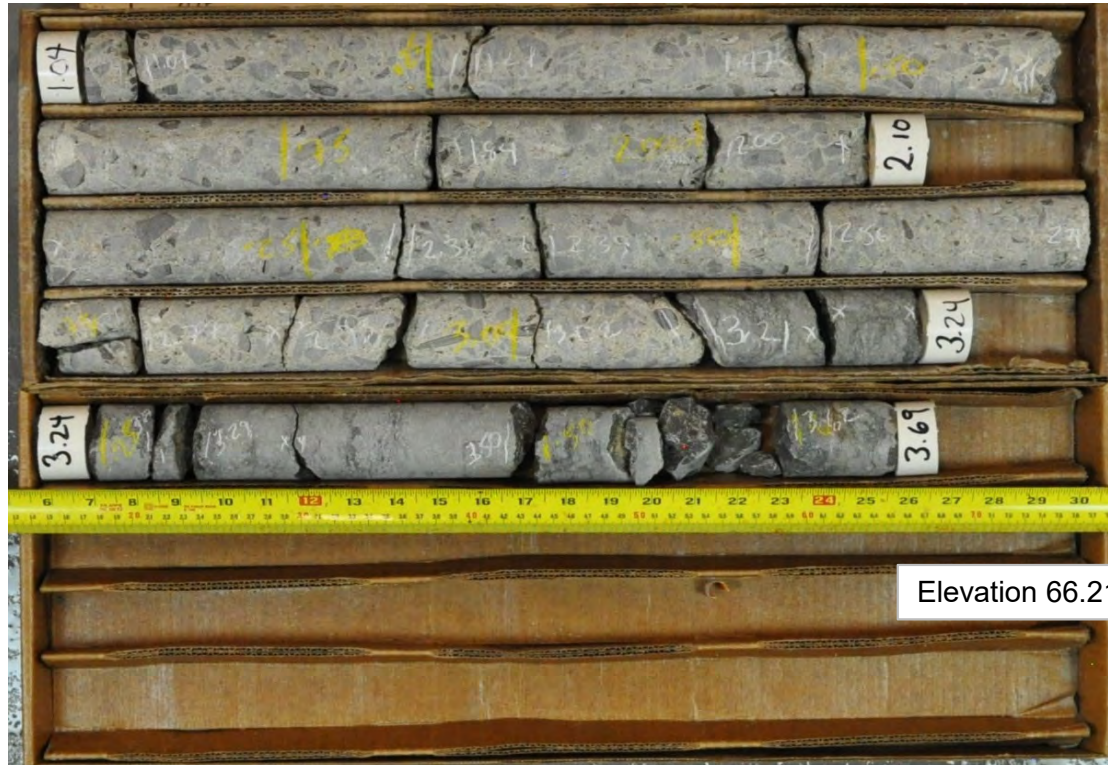

Elevation 66.21 m EOH



Foundation Investigation
Highway 417 Overpass Structures at Bronson Avenue
Ottawa, Ontario

Project No.	1655214 / 1130
Drawn:	KS
Date:	2017-09-08
Review:	KCP

Figure A7

CH 17-C13 (Dry)
Core Box 1 of 1

Elevation 68.81 m Top of Footing

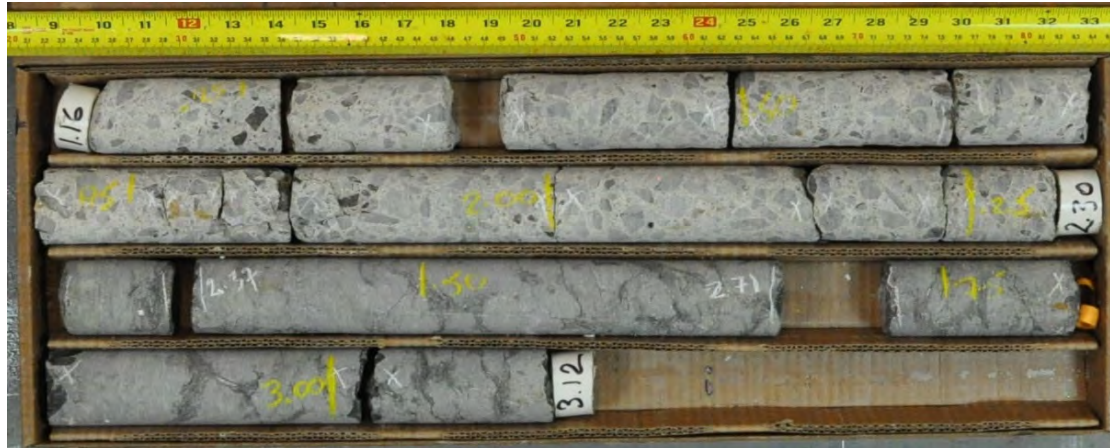

Elevation 66.85 m EOH



Foundation Investigation
Highway 417 Overpass Structures at Bronson Avenue
Ottawa, Ontario

Project No.	1655214 / 1130
Drawn:	KS
Date:	2017-09-08
Review:	KCP

Figure A9

CH 17-C13 (Wet)
Core Box 1 of 1

Elevation 68.81 m Top of Footing

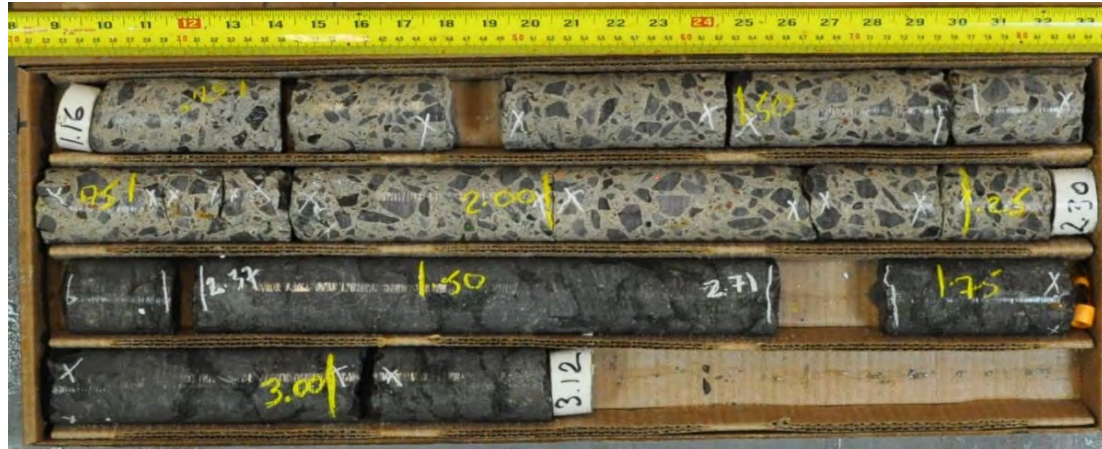

Elevation 66.85 m EOH



Foundation Investigation
Highway 417 Overpass Structures at Bronson Avenue
Ottawa, Ontario

Project No.	1655214 / 1130
Drawn:	KS
Date:	2017-09-08
Review:	KCP

Figure A10

CH 17-C17 (Dry)
Core Box 1 of 1

Elevation 68.60 m Top of Footing



Foundation Investigation
Highway 417 Overpass Structures at Bronson Avenue
Ottawa, Ontario

Project No.	1655214 / 1130
Drawn:	KS
Date:	2017-09-08
Review:	KCP

Figure A11

CH 17-C17 (Wet)
Core Box 1 of 1

Elevation 68.60 m Top of Footing

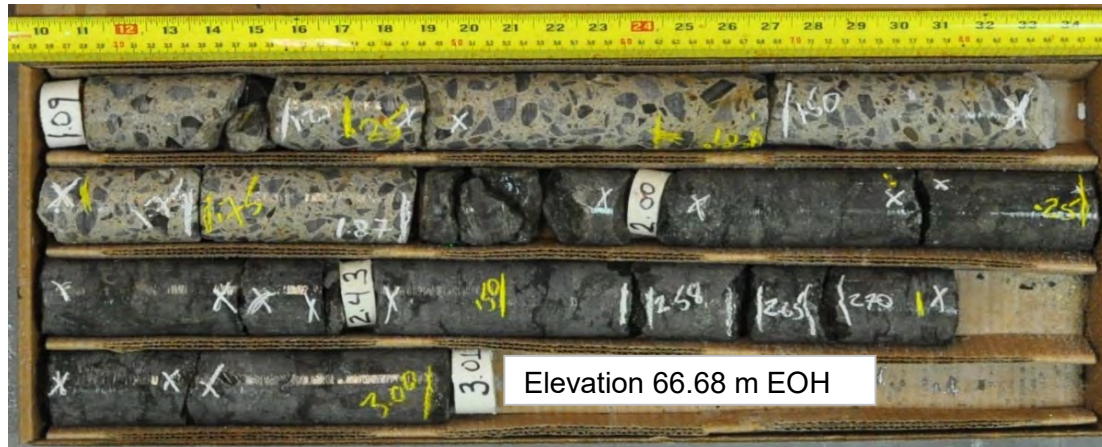

Foundation Investigation
Highway 417 Overpass Structures at Bronson Avenue
Ottawa, Ontario

Project No.	1655214 / 1130
Drawn:	KS
Date:	2017-09-08
Review:	KCP

Figure A12

CH 17-C19 (Dry)
Core Box 1 of 1

Elevation 68.42 m Top of Footing



Elevation 67.09 m EOH



Foundation Investigation
Highway 417 Overpass Structures at Bronson Avenue
Ottawa, Ontario

Project No.	1655214 / 1130
Drawn:	KS
Date:	2017-09-08
Review:	KCP

Figure A13

CH 17-C19 (Wet)
Core Box 1 of 1

Elevation 68.42 m Top of Footing



Elevation 67.09 m EOH



Foundation Investigation
Highway 417 Overpass Structures at Bronson Avenue
Ottawa, Ontario

Project No.	1655214 / 1130
Drawn:	KS
Date:	2017-09-08
Review:	KCP

Figure A14

CH 17-C24 (Dry)
Core Box 1 of 1

Elevation 68.42 m Top of Footing



Elevation 66.94 m EOH



Foundation Investigation
Highway 417 Overpass Structures at Bronson Avenue
Ottawa, Ontario

Project No.	1655214 / 1130
Drawn:	KS
Date:	2017-09-08
Review:	KCP

Figure A15

CH 17-C24 (Wet)
Core Box 1 of 1

Elevation 68.42 m Top of Footing

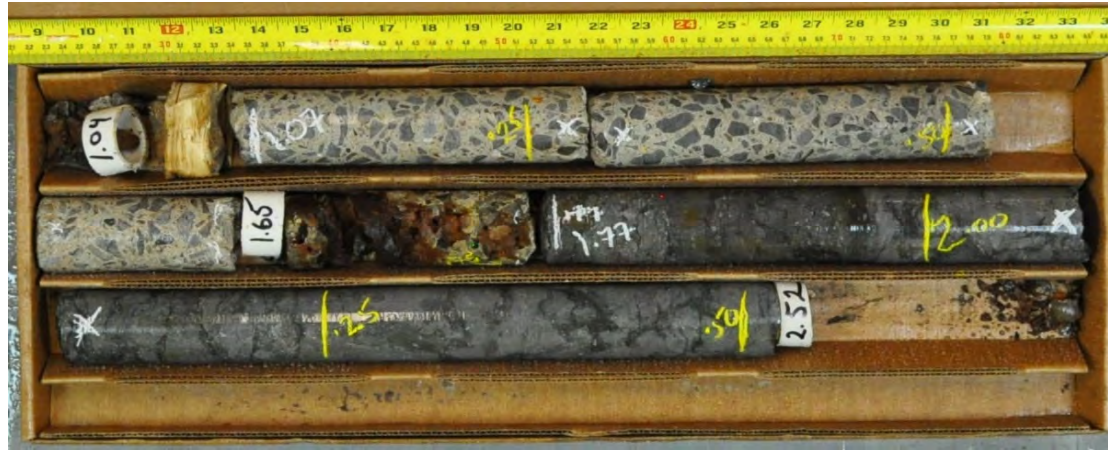

Elevation 66.94 m EOH



Foundation Investigation
Highway 417 Overpass Structures at Bronson Avenue
Ottawa, Ontario

Project No.	1655214 / 1130
Drawn:	KS
Date:	2017-09-08
Review:	KCP

Figure A16

BH 17-131 (Dry)
Core Box 1 of 2 and 2

Elevation 68.24 m Top of Bedrock



Elevation 65.10 m EOH



GOLDER

Foundation Investigation
Highway 417 Overpass Structures at Bronson Avenue
Ottawa, Ontario

Project No.	1655214 / 1130
Drawn:	KS
Date:	2017-09-08
Review:	KCP

Figure A17

**BH 17-131 (Wet)
Core Box 1 and 2 of 2**

Elevation 68.24 m Top of Bedrock

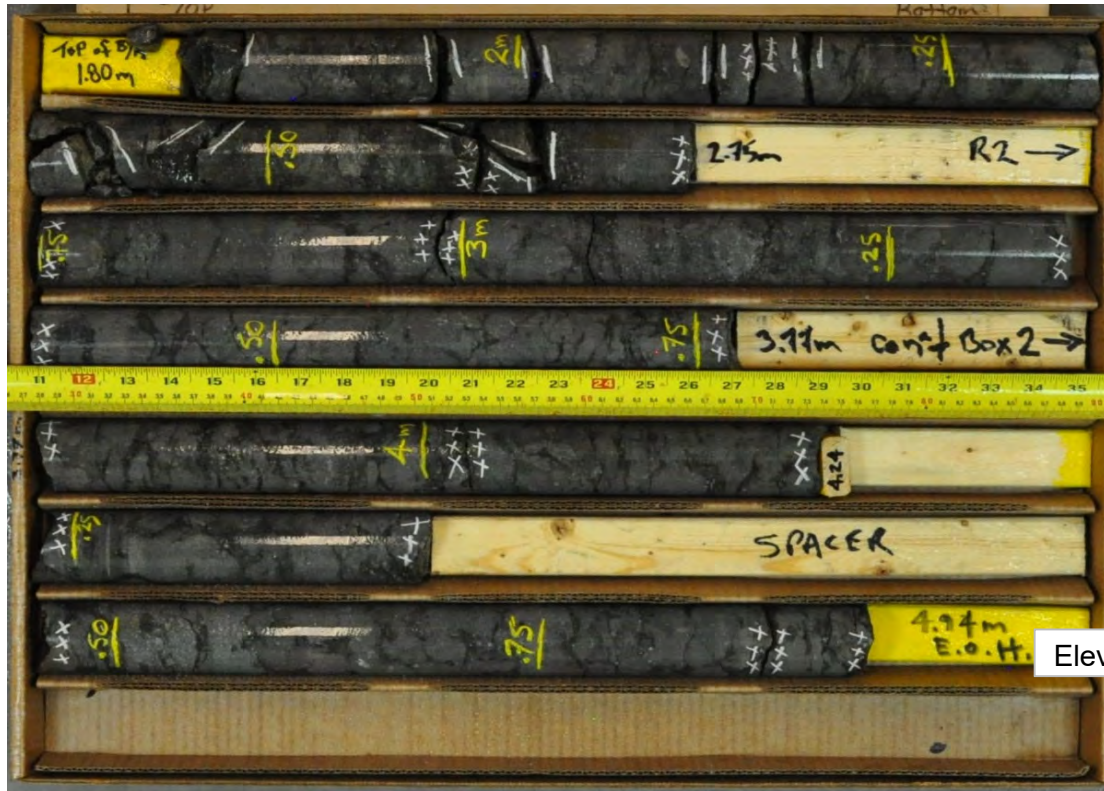

Elevation 65.10 m EOH



Foundation Investigation
Highway 417 Overpass Structures at Bronson Avenue
Ottawa, Ontario

Project No.	1655214 / 1130
Drawn:	KS
Date:	2017-09-08
Review:	KCP

Figure A18

BH 17-132 (Dry)
Core Box 1 and 2 of 2

Elevation 68.12 m Top of Bedrock

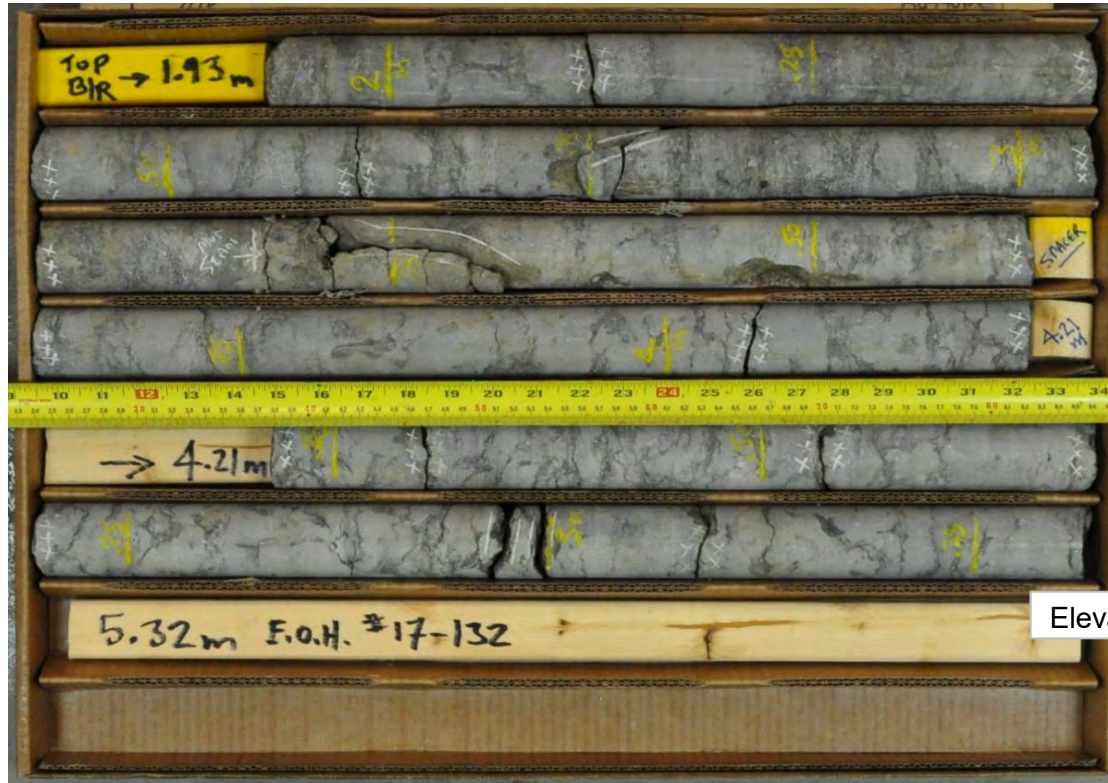

Elevation 64.73 m EOH



GOLDER

Foundation Investigation
Highway 417 Overpass Structures at Bronson Avenue
Ottawa, Ontario

Project No.	1655214 / 1130
Drawn:	KS
Date:	2017-09-08
Review:	KCP

Figure A19

BH 17-132 (Wet)
Core Box 1 and 2 of 2

Elevation 68.12 m Top of Bedrock

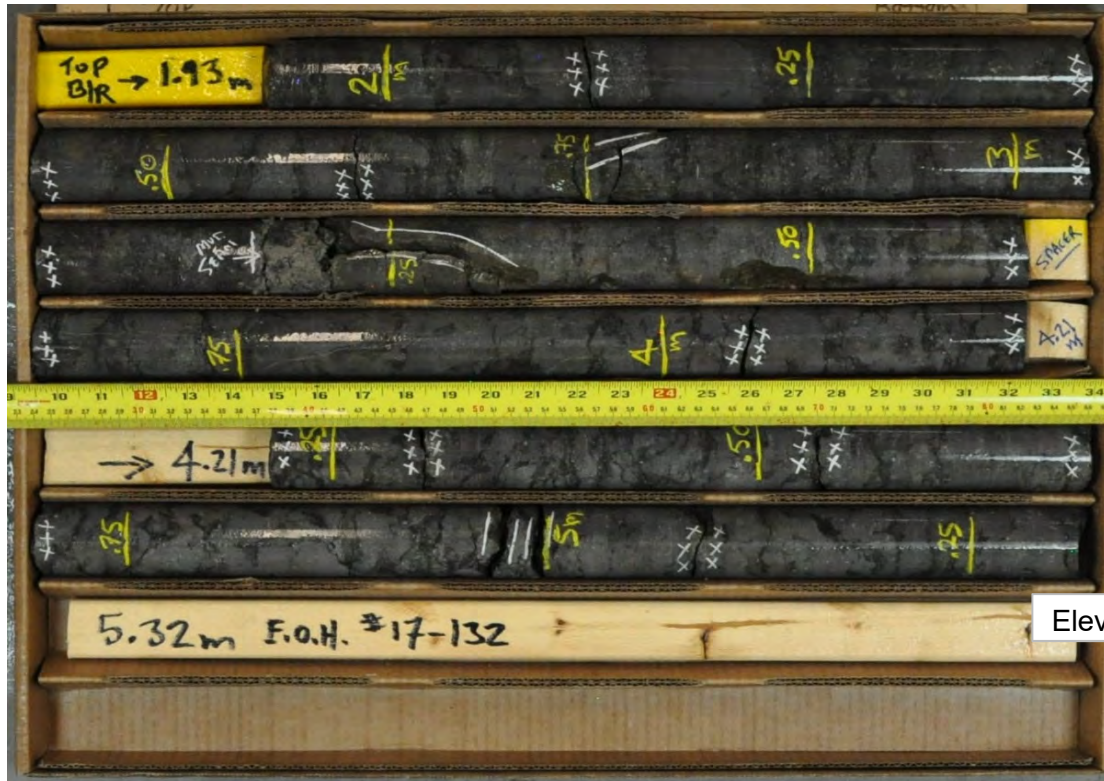

Elevation 64.73 m EOH



Foundation Investigation
Highway 417 Overpass Structures at Bronson Avenue
Ottawa, Ontario

Project No.	1655214 / 1130
Drawn:	KS
Date:	2017-09-08
Review:	KCP

Figure A20

BH 17-133 (Dry)
Core Box 1 and 2 of 2

Elevation 68.36 m Top of Bedrock

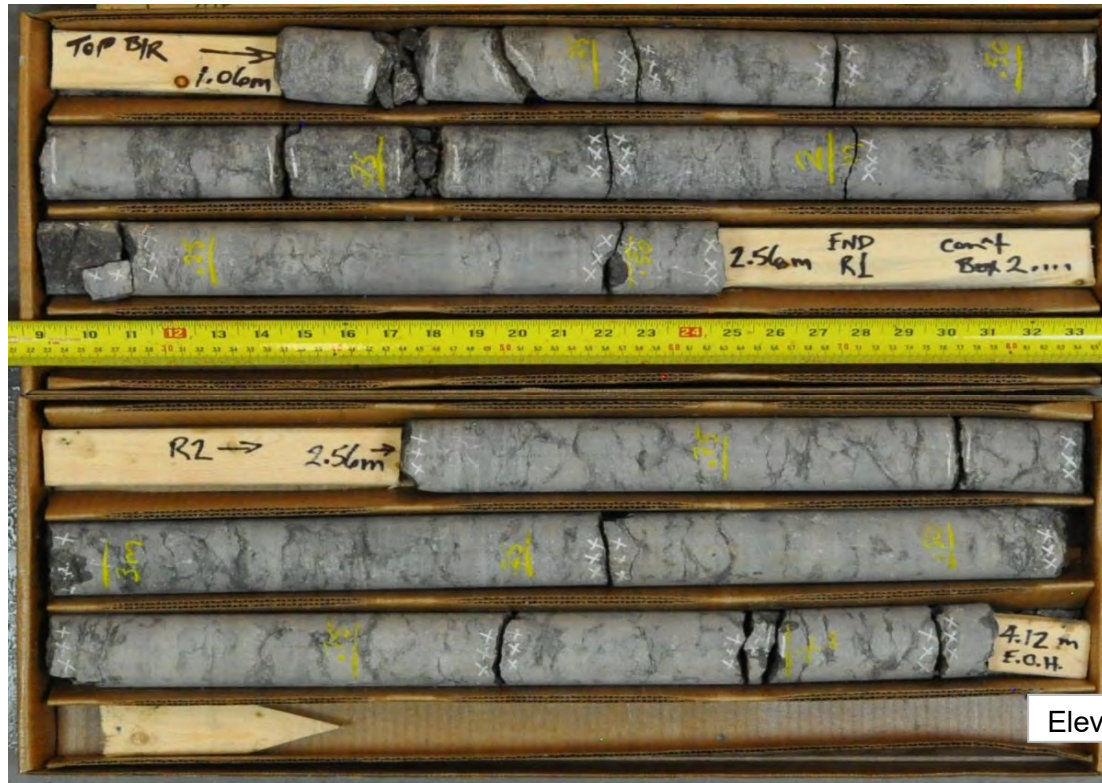

Elevation 65.30 m EOH



Foundation Investigation
Highway 417 Overpass Structures at Bronson Avenue
Ottawa, Ontario

Project No.	1655214 / 1130
Drawn:	KS
Date:	2017-09-08
Review:	KCP

Figure A21

**BH 17-133 (Wet)
Core Box 1 and 2 of 2**

Elevation 68.36 m Top of Bedrock



Elevation 65.30 m EOH



Foundation Investigation
Highway 417 Overpass Structures at Bronson Avenue
Ottawa, Ontario

Project No.	1655214 / 1130
Drawn:	KS
Date:	2017-09-08
Review:	KCP

Figure A22

BH 17-134 (Dry)
Core Box 1 and 2 of 2

Elevation 67.45 m Top of Bedrock

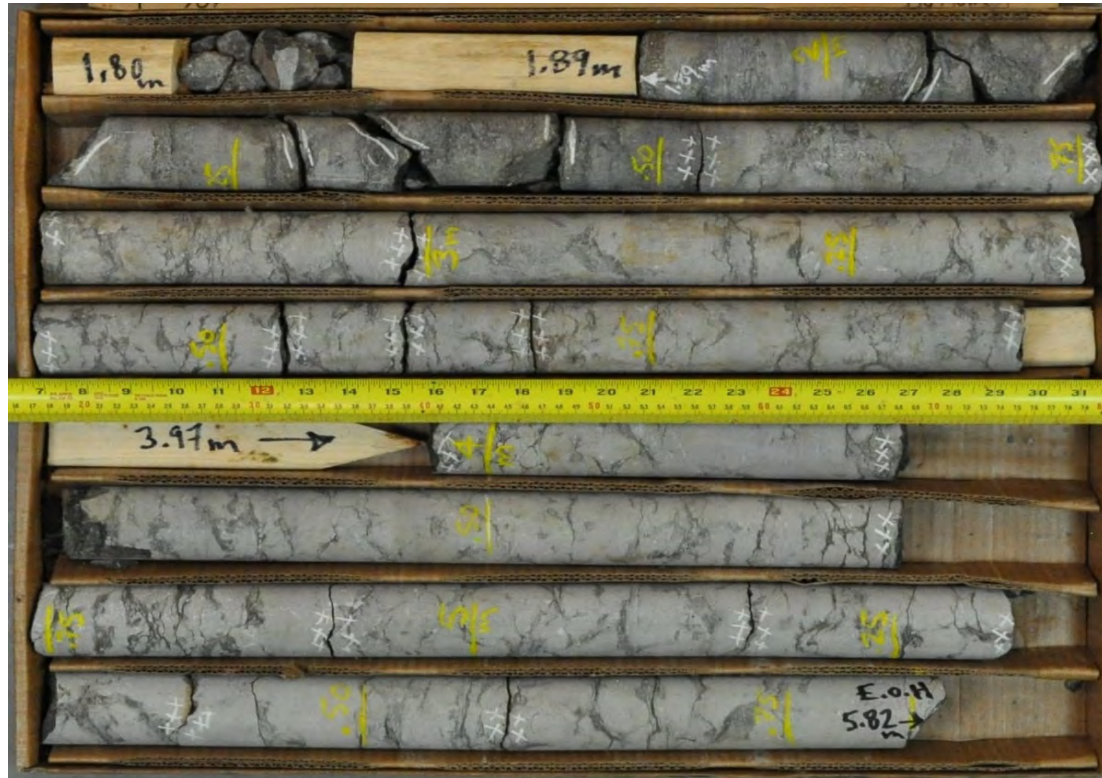

Elevation 63.52 m EOH



Foundation Investigation
Highway 417 Overpass Structures at Bronson Avenue
Ottawa, Ontario

Project No.	1655214 / 1130
Drawn:	KS
Date:	2017-09-08
Review:	KCP

Figure A23

**BH 17-134 (Wet)
Core Box 1 and 2 of 2**

Elevation 67.45 m Top of Bedrock



Elevation 63.52 m EOH



Foundation Investigation
Highway 417 Overpass Structures at Bronson Avenue
Ottawa, Ontario

Project No.	1655214 / 1130
Drawn:	KS
Date:	2017-09-08
Review:	KCP

Figure A24

**BH 18-1301 (Dry)
Core Box 1 and 2 of 2**

Elevation 69.26 m Top of Footing



Elevation 66.15 m EOH



Foundation Investigation
Highway 417 Overpass Structures at Bronson Avenue
Ottawa, Ontario

Project No.	1655214 / 1130
Drawn:	KS
Date:	2019-03-19
Review:	KCP

Figure A25

**BH 18-1301 (Wet)
Core Box 1 and 2 of 2**

Elevation 69.26 m Top of Footing



Elevation 66.15 m EOH



Foundation Investigation
Highway 417 Overpass Structures at Bronson Avenue
Ottawa, Ontario

Project No.	1655214 / 1130
Drawn:	KS
Date:	2019-03-19
Review:	KCP

Figure A26

**BH 18-1302 (Dry)
Core Box 1 and 2 of 2**

Elevation 69.45 m Top of Footing

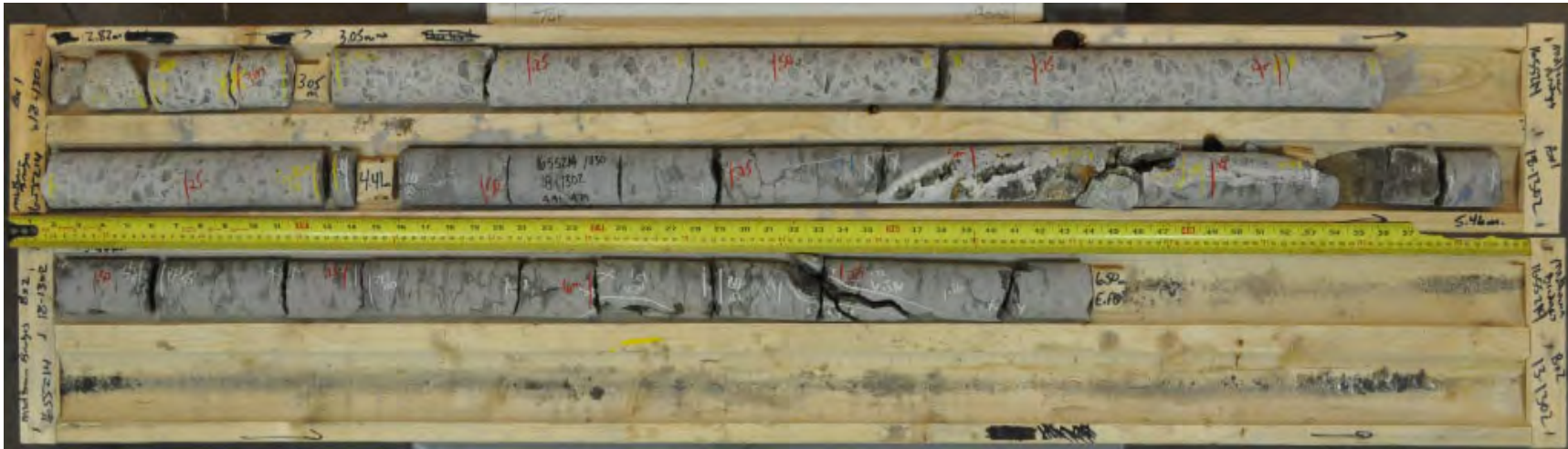

Elevation 65.77 m EOH



Foundation Investigation
Highway 417 Overpass Structures at Bronson Avenue
Ottawa, Ontario

Project No.	1655214 / 1130
Drawn:	KS
Date:	2019-03-19
Review:	KCP

Figure A27

**BH 18-1302 (Wet)
Core Box 1 and 2 of 2**

Elevation 69.45 m Top of Footing



Elevation 65.77 m EOH



Foundation Investigation
Highway 417 Overpass Structures at Bronson Avenue
Ottawa, Ontario

Project No.	1655214 / 1130
Drawn:	KS
Date:	2019-03-19
Review:	KCP

Figure A28

**BH 18-1303 (Dry)
Core Box 1 and 2 of 2**

Elevation 68.41 m Top of Footing

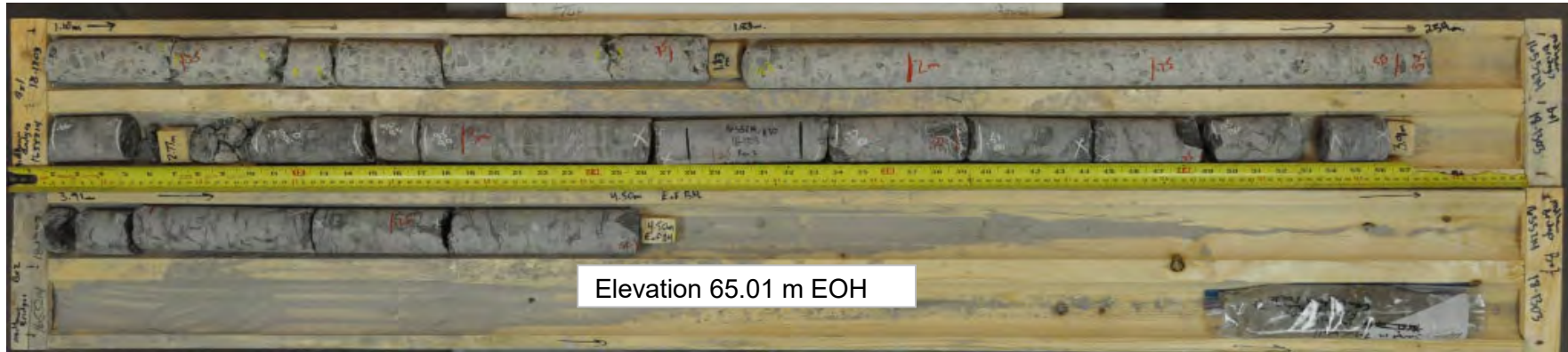

Foundation Investigation
Highway 417 Overpass Structures at Bronson Avenue
Ottawa, Ontario

Project No.	1655214 / 1130
Drawn:	KS
Date:	2019-03-19
Review:	KCP

Figure A29

**BH 18-1303 (Wet)
Core Box 1 and 2 of 2**

Elevation 68.41 m Top of Footing

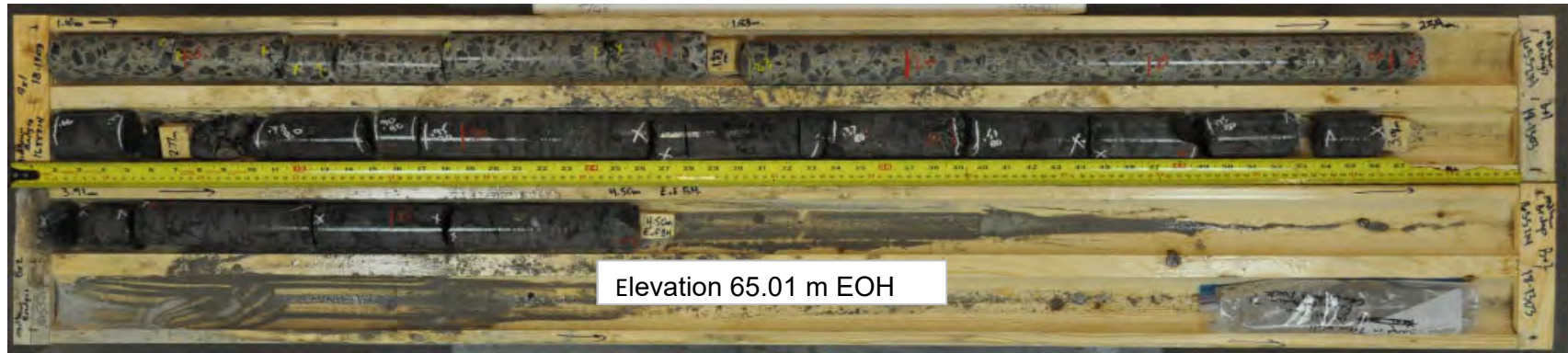

Foundation Investigation
Highway 417 Overpass Structures at Bronson Avenue
Ottawa, Ontario

Project No.	1655214 / 1130
Drawn:	KS
Date:	2019-03-19
Review:	KCP

Figure A30

**BH 18-1304 (Dry)
Core Box 1 and 2 of 2**

Elevation 68.95 m Top of Footing



Foundation Investigation
Highway 417 Overpass Structures at Bronson Avenue
Ottawa, Ontario

Project No.	1655214 / 1130
Drawn:	KS
Date:	2019-03-19
Review:	KCP

Figure A31

**BH 18-1304 (Wet)
Core Box 1 and 2 of 2**

Elevation 68.95 m Top of Footing



Elevation 65.85 m EOH



Foundation Investigation
Highway 417 Overpass Structures at Bronson Avenue
Ottawa, Ontario

Project No.	1655214 / 1130
Drawn:	KS
Date:	2019-03-19
Review:	KCP

Figure A32

**TABLE A1: Concrete Core Condition Assessment
Existing Concrete Footing - Bronson Avenue**

Project No. 1655214 - 1130

20-Oct-17 CNM



Bronson Avenue

17-C01 : - 1.01 - 2.45

- Top surface broken up.
- Good condition, with only mechanical breaks.
- Well formed but unbonded joint to rock.

17-C04 : - 1.08 - 1.99

- Slightly degraded top surface.
- Voids and mechanical break at 1.24.
- Good condition to 1.95.
- 1.95-1.99 : Broken up and poor bond to rock.

17-C09 : - 1.08 - 5.00

- Top surface intact but core broken at shallow depth ... may be pre-existing crack.
- 1.62-2.20 : Damaged section likely due to coring longitudinally through re-bar.
- 2.60-3.15 : Coring damage due to apparent cold joint, plus broken pieces with flat formed surfaces, but no wood or debris recovered.
- 3.15-4.45 : Good condition.
- 4.45 : Horizontal joint, appearance of pouring in water.
- 4.52-5.00 : Much poorer quality concrete; likely mud-slab.
- Excellent bond to rock.

17-C11 : - 1.04 - 3.21

- Good condition, with only mechanical breaks.
- Good bond to rock.

17-C13 : - 1.16 - 2.30

- Good condition, with only mechanical breaks.
- Poor bond to rock.

17-C17 : - 1.09 - 1.87

- Good condition, with only mechanical breaks.
- No bond to rock. Mud in joint.

17-C19 : - 1.20 - 1.81

- Good to fair condition; mechanical breaks have coring damage (spun), and areas of abraded paste.
- Poor bond to rock.

17-C24 : - 1.07 - 1.77

- Wood at surface, but no intact formed surface.
- 1.07-1.53 : Good condition; mechanical breaks only.
- 1.53 : Flat cold joint, likely to mud-slab, no bond.
- 1.53-1.65 : Lesser quality concrete; some paste abraded.
- 1.65-1.77 : Heavily corroded re-bar splice in heavily voided concrete (likely poured in water).
 - Voids heavily infilled with rust.
- No bond to rock.

APPENDIX B

Laboratory Test Results, Current Investigation

Figure B1 – Grain Size Distribution Test Results –
Sand and Gravel (Fill)

Figure B2 – Grain Size Distribution Test Results – Sand (Fill)

Figure B3 – Grain Size Distribution Test Results – Sand (Fill)

Figure B4 – Grain Size Distribution Test Results – Silt (Fill)

Figure B5 – Grain Size Distribution Test Results – Sand (Fill)

Figure B6 – Grain Size Distribution Test Results – Silty Sand

Figure B7 – Grain Size Distribution Test Results – Silt

Figure B8 – Grain Size Distribution Test Results – Glacial Till

Figure B9 – Summary of Laboratory Compressive Strength
Unconfined Compression Tests

SAND AND GRAVEL (FILL)

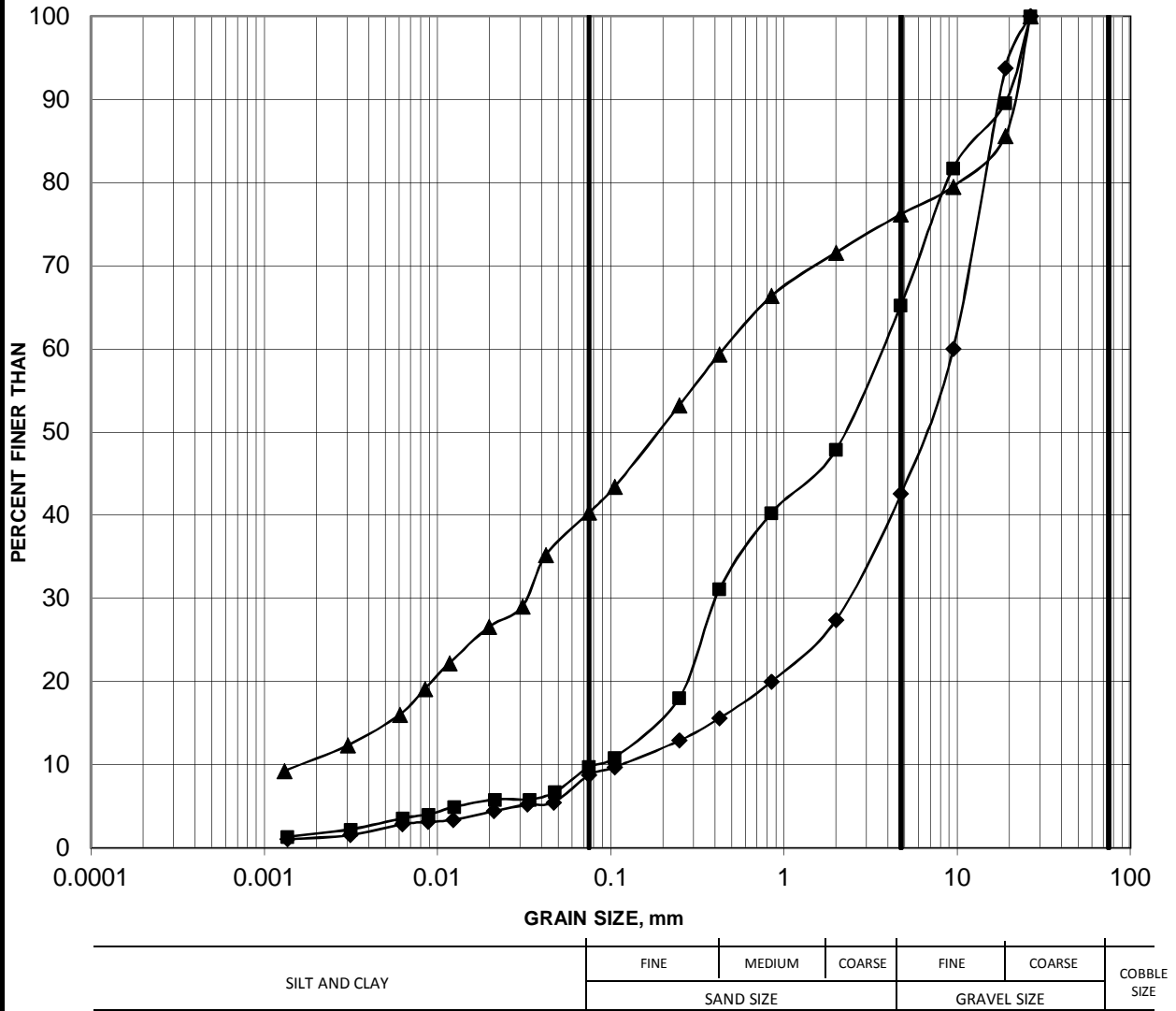

Borehole	Sample	Depth (m)
17-C01	1	0.10-0.20
17-C13	1	0.30-0.40
18-1305	9	6.10-6.71

GRAIN SIZE DISTRIBUTION

FIGURE B2

SAND (FILL)

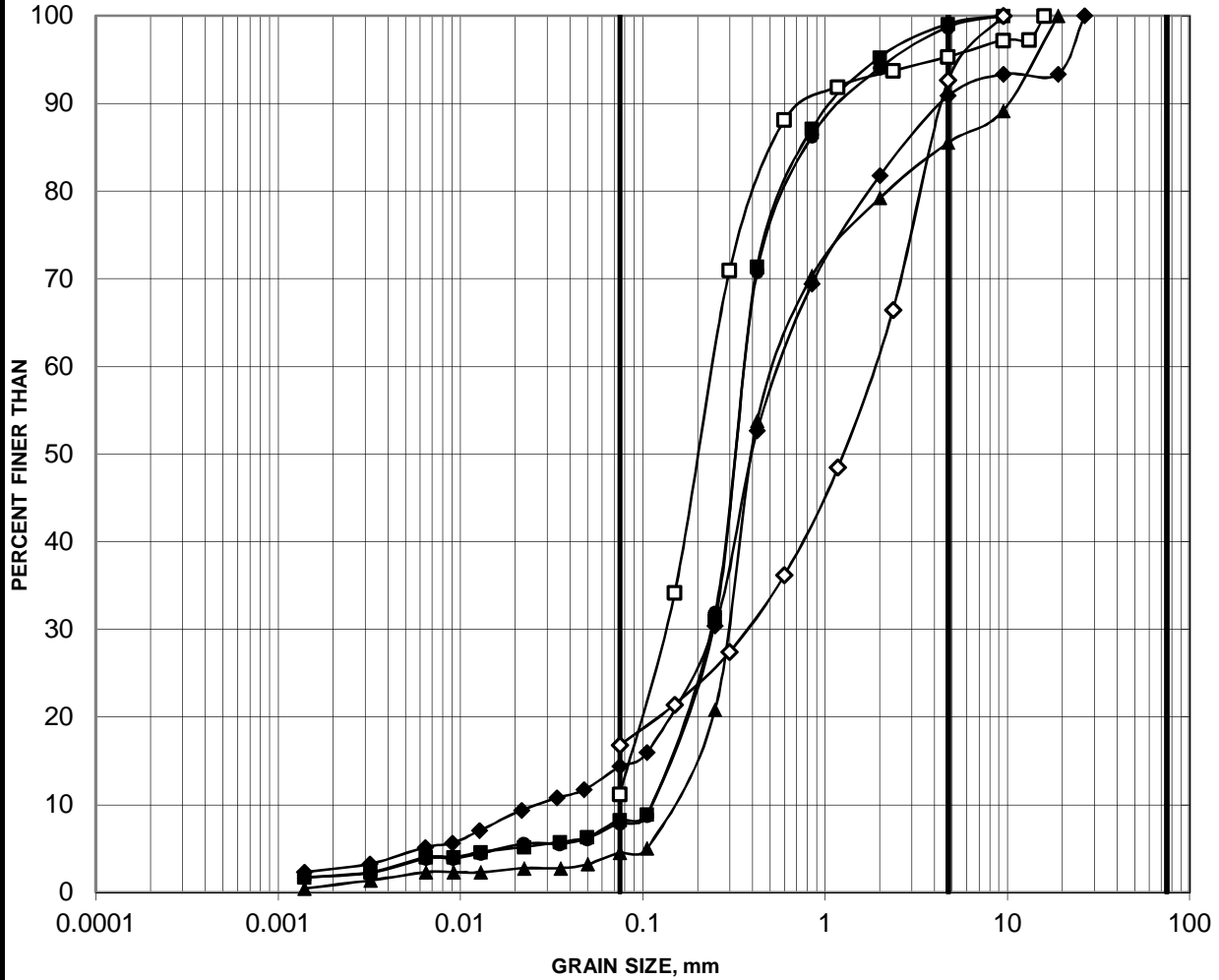

SILT AND CLAY	FINE	MEDIUM	COARSE	FINE	COARSE	COBBLE SIZE
	SAND SIZE			GRAVEL SIZE		

Borehole	Sample	Depth (m)
17-131	1	1.50-2.80
17-133	1	1.20-3.00
17-C09	2	0.75-0.90
17-C19	2	0.60-0.90
18-1301	3	1.22-1.83
18-1307	3	1.52-2.13

GRAIN SIZE DISTRIBUTION

FIGURE B3

SAND (FILL)

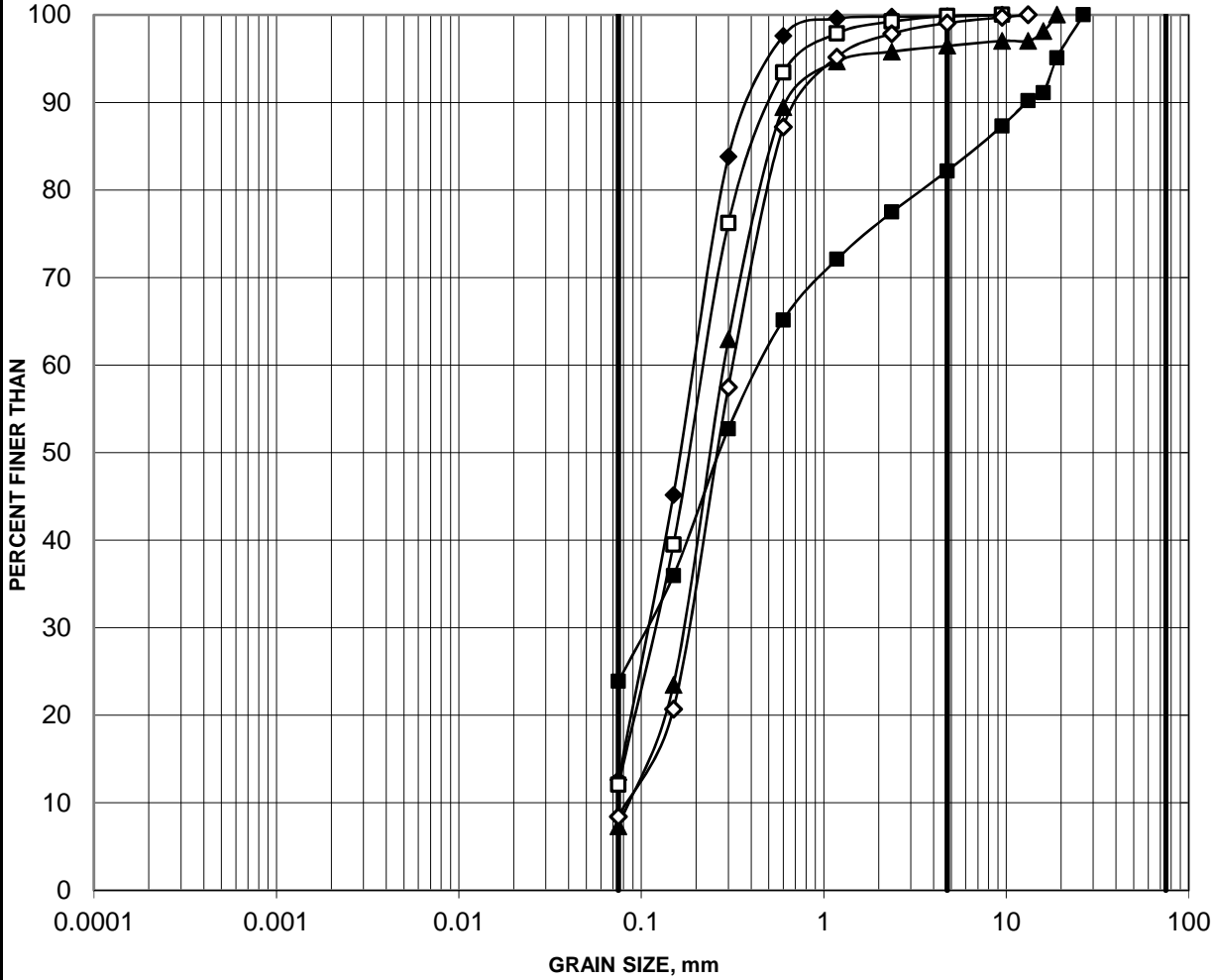

SILT AND CLAY	FINE	MEDIUM	COARSE	FINE	COARSE	COBBLE SIZE
	SAND SIZE			GRAVEL SIZE		

Borehole	Sample	Depth (m)
■	18-1302	3
◆	18-1305	6
▲	18-1306	7
□	18-1307	6
◇	18-1308	7

GRAIN SIZE DISTRIBUTION

FIGURE B4

SILT (FILL)

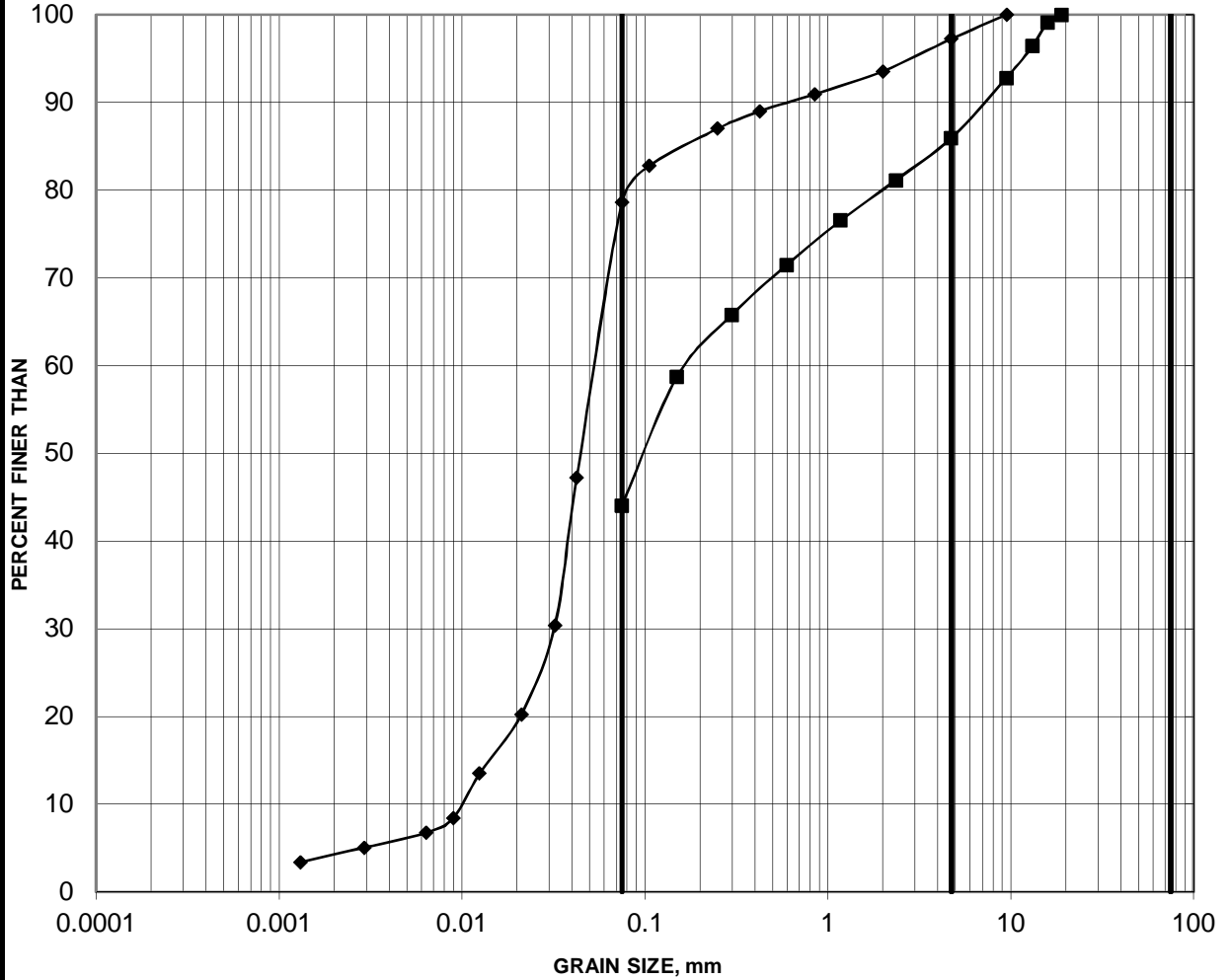

SILT AND CLAY	FINE	MEDIUM	COARSE	FINE	COARSE	COBBLE SIZE
	SAND SIZE			GRAVEL SIZE		

Borehole	Sample	Depth (m)
■ 18-1309	3	1.52-2.13
◆ 18-1310	6A	4.57-5.18

GRAIN SIZE DISTRIBUTION

FIGURE B5

SAND (FILL)

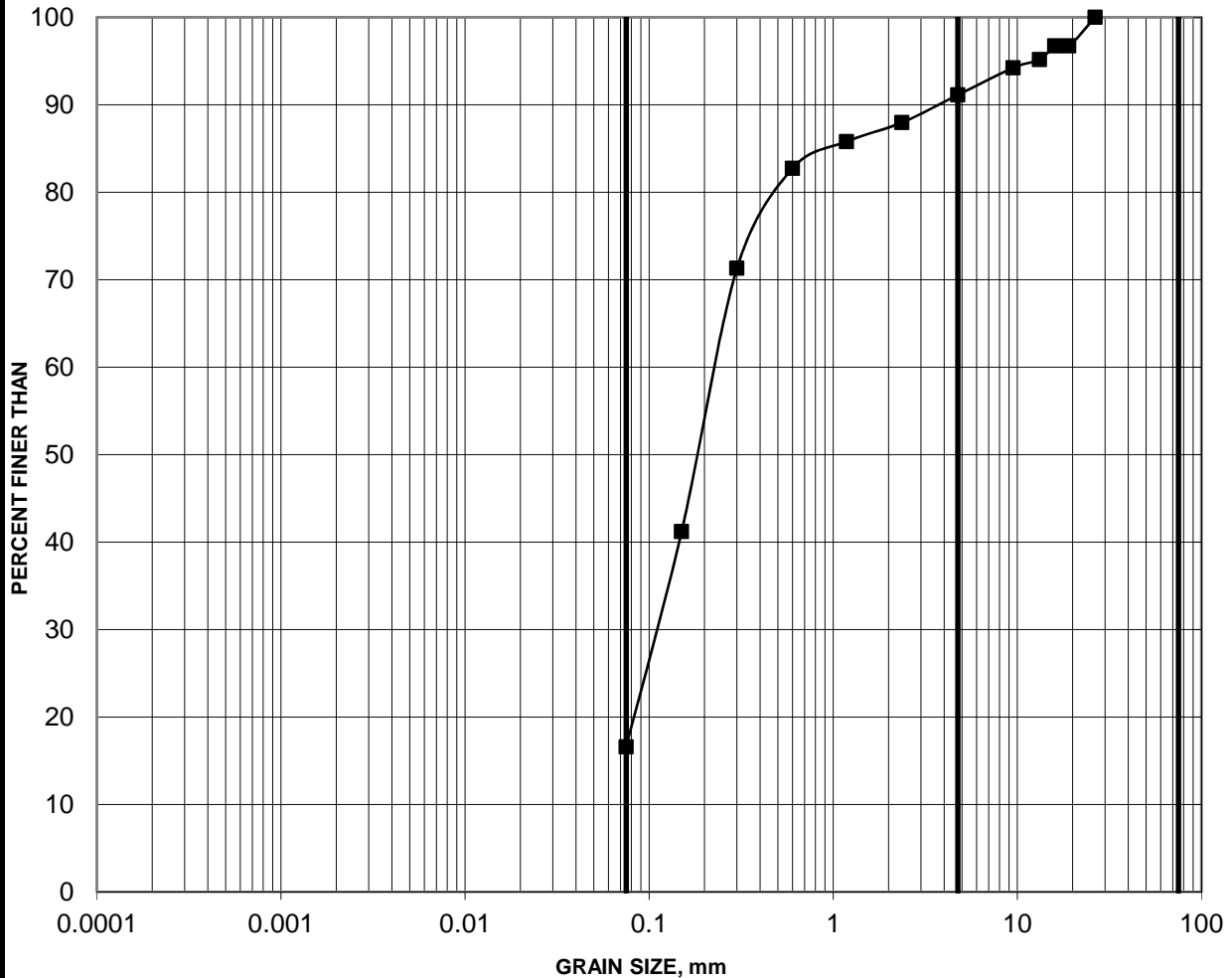

SILT AND CLAY	FINE	MEDIUM	COARSE	FINE	COARSE	COBBLE SIZE
	SAND SIZE			GRAVEL SIZE		

Borehole	Sample	Depth (m)
■ 18-1310	3	2.29-2.90

GRAIN SIZE DISTRIBUTION

FIGURE B6

SILTY SAND

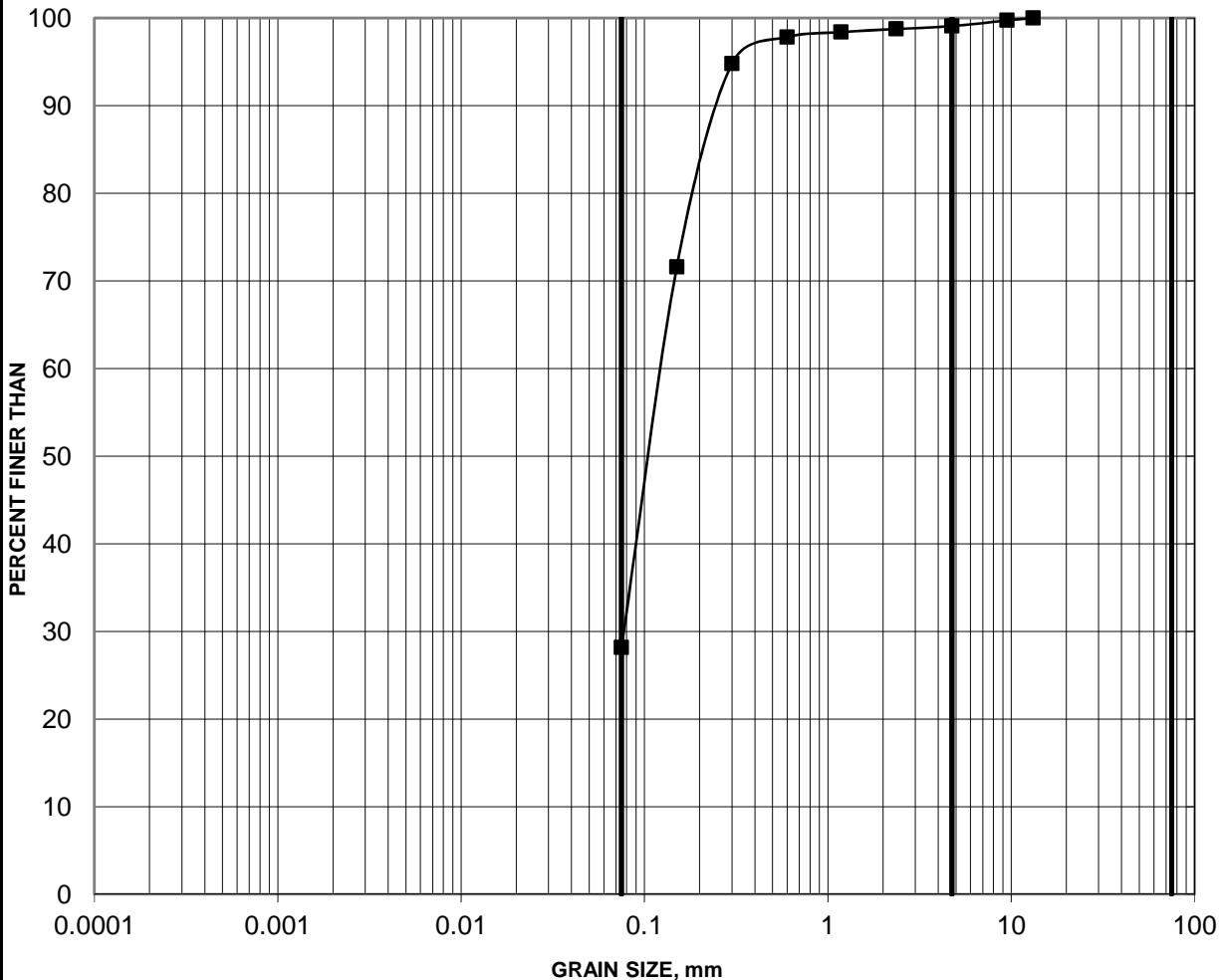

SILT AND CLAY	FINE	MEDIUM	COARSE	FINE	COARSE	COBBLE SIZE
	SAND SIZE			GRAVEL SIZE		

Borehole	Sample	Depth (m)
■ 18-1311	4	2.29-2.90

GRAIN SIZE DISTRIBUTION

FIGURE B7

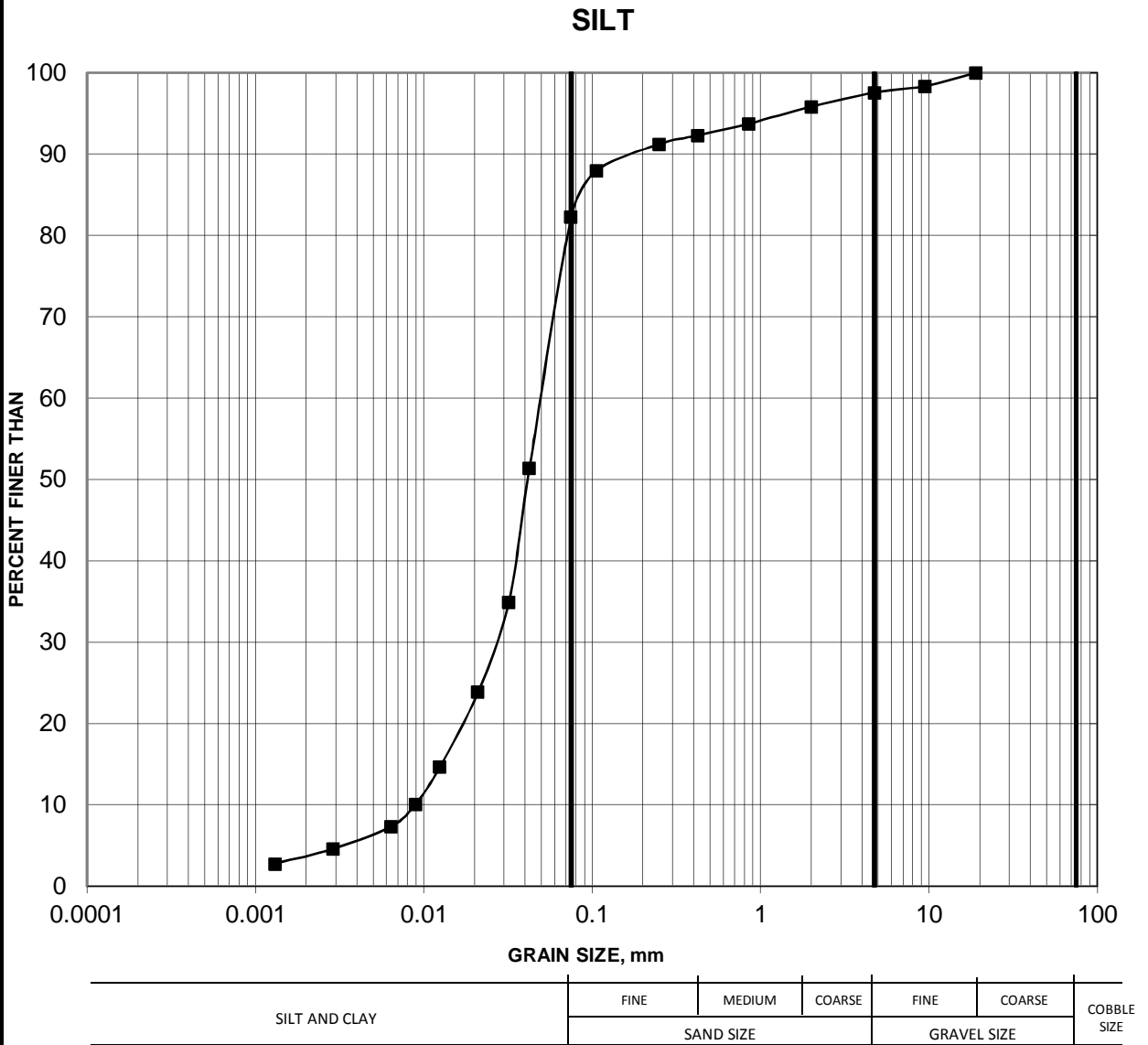

Borehole	Sample	Depth (m)
—■— 18-1311	8	5.33-5.94

GLACIAL TILL

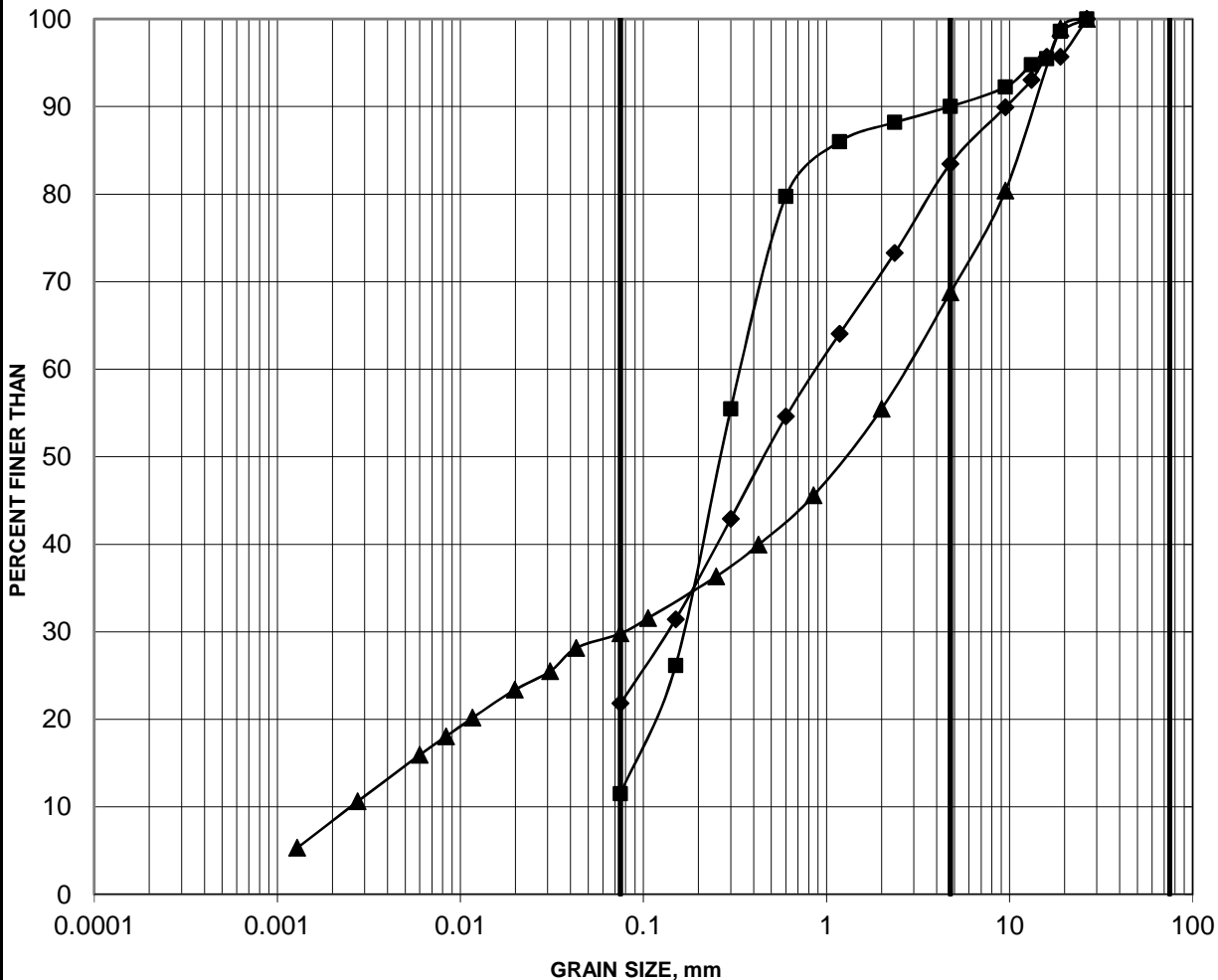

SILT AND CLAY	FINE	MEDIUM	COARSE	FINE	COARSE	COBBLE SIZE
	SAND SIZE			GRAVEL SIZE		

Borehole	Sample	Depth (m)
■ 18-1306	9	5.33-5.94
◆ 18-1308	10	6.86-7.47
▲ 18-1311	10	6.86-7.35

**SUMMARY OF LABORATORY COMPRESSIVE STRENGTH
UNCONFINED COMPRESSION TESTS**

FIGURE B9

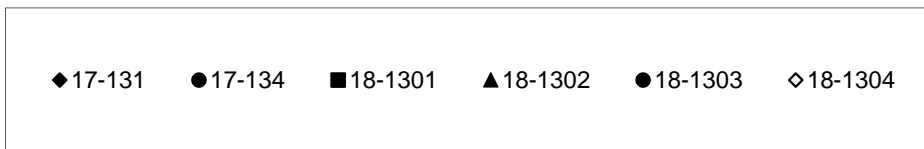
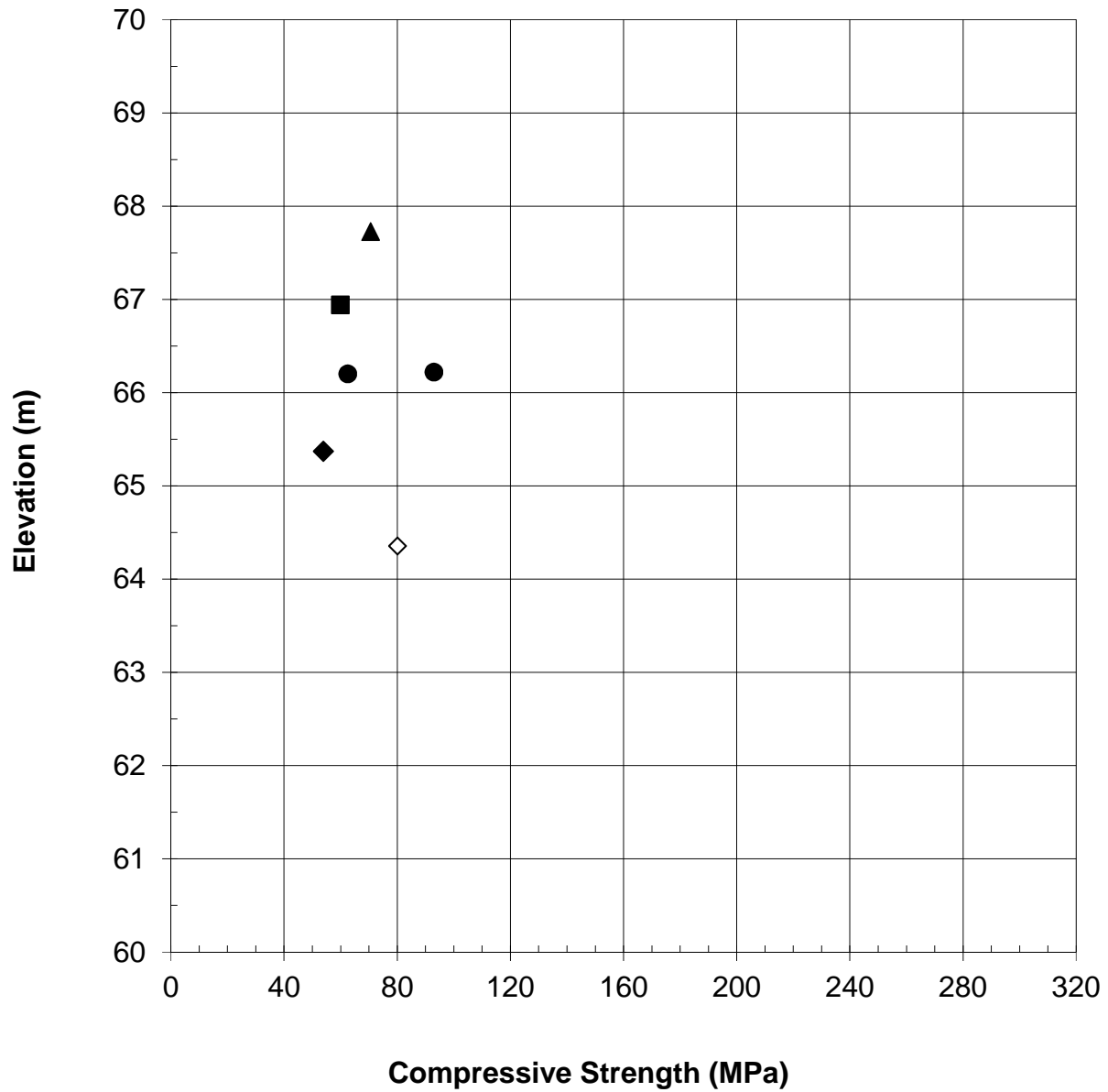

APPENDIX C

Previous Investigations, GEOCREG 31G05-043 (1961)
Record of Boreholes 1 to 6
Boring Plan and Soil Stratigraphy
Laboratory Test Results

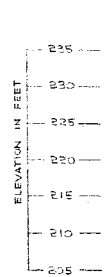
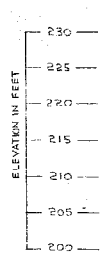
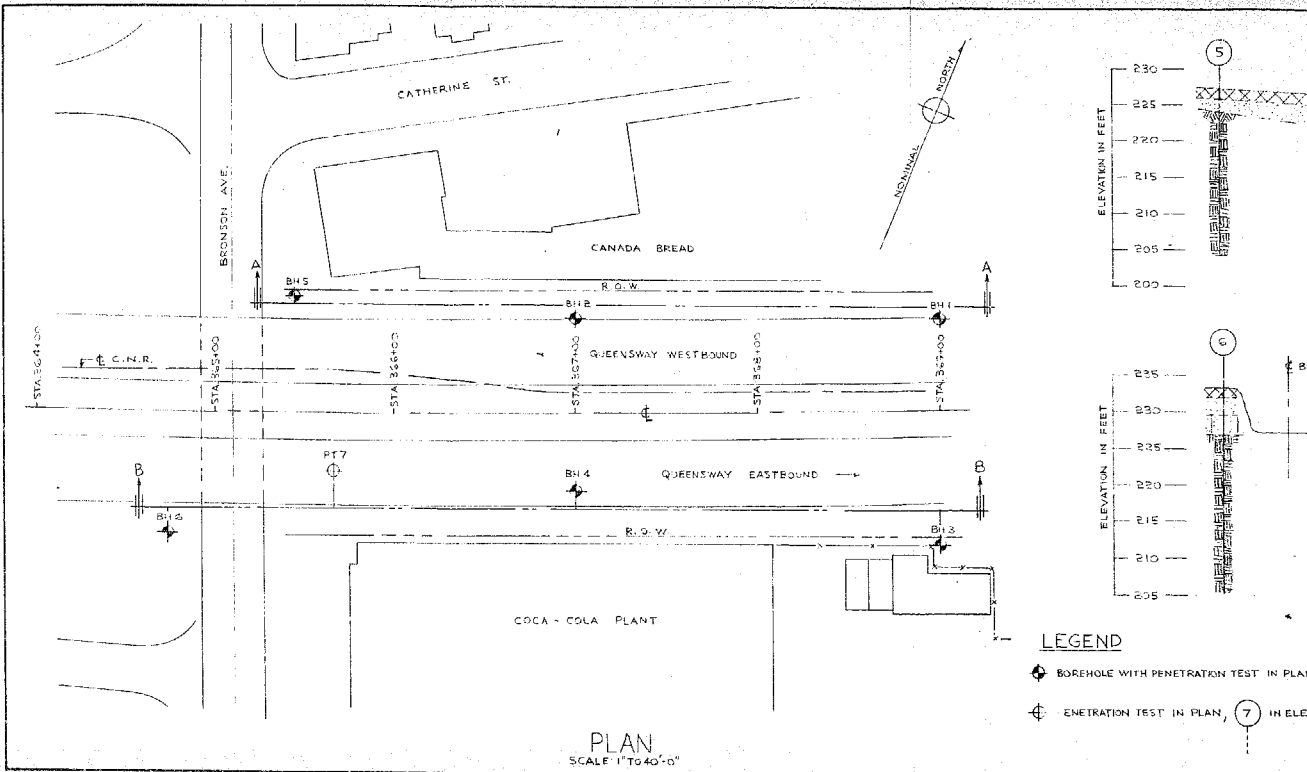

LEGEND

- ◆ BOREHOLE WITH PENETRATION TEST IN PLAN
- ⊕ PENETRATION TEST IN PLAN, 7 IN ELEV.

PLAN
SCALE 1" TO 40'-0"

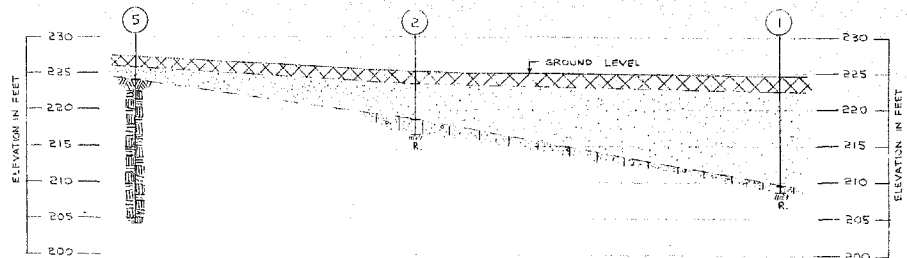

SECTION A-A
SCALE: HORIZ. 1" TO 40'-0"
VERT. 1" TO 10'-0"

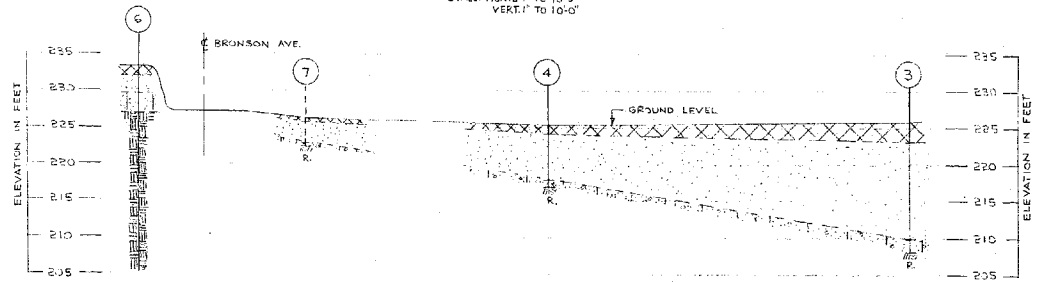

SECTION B-B
SCALE: HORIZ. 1" TO 40'-0"
VERT. 1" TO 10'-0"

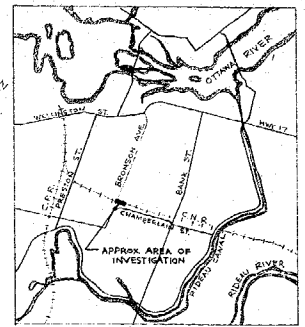

KEY PLAN
SCALE: 1" TO 3,800' (APPROX.)

STRATIGRAPHY

- LOOSE TO DENSE DARK BROWN HETEROGENEOUS FILL
- COMPACT TO DENSE GREY-BROWN TO GREY FINE TO MEDIUM SAND.
- DENSE TO VERY DENSE GREY SILTY SAND WITH GRAVEL
- LIMESTONE BEDROCK
- REFUSAL - ASSUMED BEDROCK

LEGEND

- BOREHOLE WITH PENETRATION TEST IN PLAN, ① IN ELEVATION
- PENETRATION TEST IN PLAN, ⑦ IN ELEVATION

SPECIAL NOTE: DATA CONCERNING THE VARIOUS STRATA HAVE BEEN OBTAINED AT BOREHOLE LOCATIONS ONLY. THE SOIL STRATIGRAPHY BETWEEN BOREHOLES HAS BEEN INFERRED FROM GEOLOGICAL EVIDENCE AND SO MAY VARY FROM THAT SHOWN.

REFERENCE	
DRWS No.	DESCRIPTION
11-A-BE	DE LEUW CATHER & COMPANY OF CANADA LIMITED - OTTAWA QUEENWAY, STA 357+00 TO STA 369+00, R.S.W. & UTILITIES.

DE LEUW CATHER & COMPANY OF CANADA LIMITED
OTTAWA ONTARIO
PROPOSED QUEENWAY-BRONSON OVERPASS
OTTAWA ONTARIO
BORING PLAN AND SOIL STRATIGRAPHY

GOLDER & ASSOCIATES
CONSULTING CIVIL ENGINEERS
DATE: AUG. 15, 1961 SCALE: HORIZ. 1" TO 40'-0"
VERT. 1" TO 10'-0"
MADE 1.A. CHKD. 312 APPD. 312
FIGURE 1

M.I.T. GRAIN SIZE SCALE

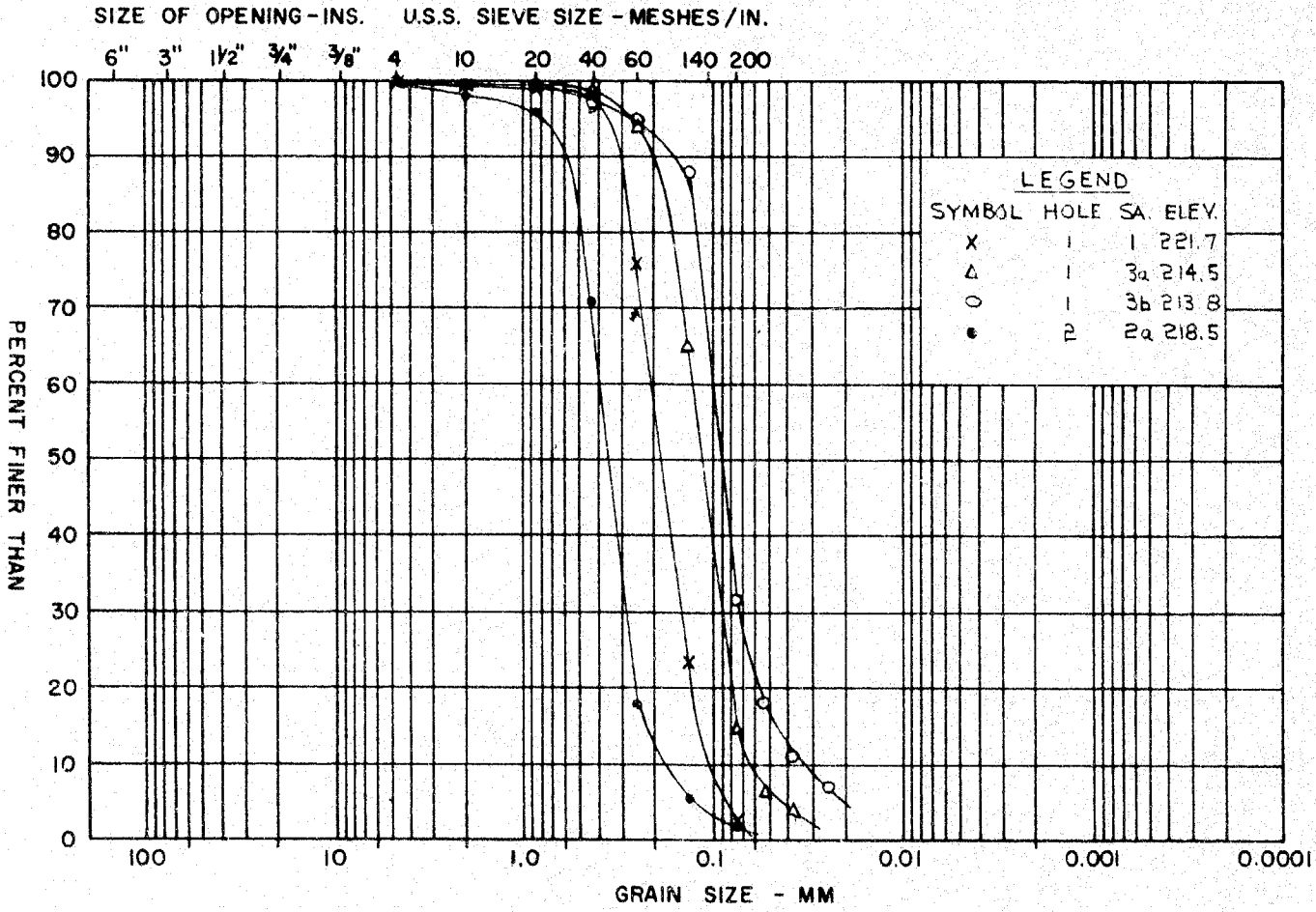

GOLDER & ASSOCIATES

GRAIN SIZE DISTRIBUTION

COBBLE SIZE	COARSE	MEDIUM	FINE	COARSE	MEDIUM	FINE	SILT SIZE	CLAY SIZE
	GRAVEL SIZE			SAND SIZE				

FIGURE 2

M.I.T. GRAIN SIZE SCALE

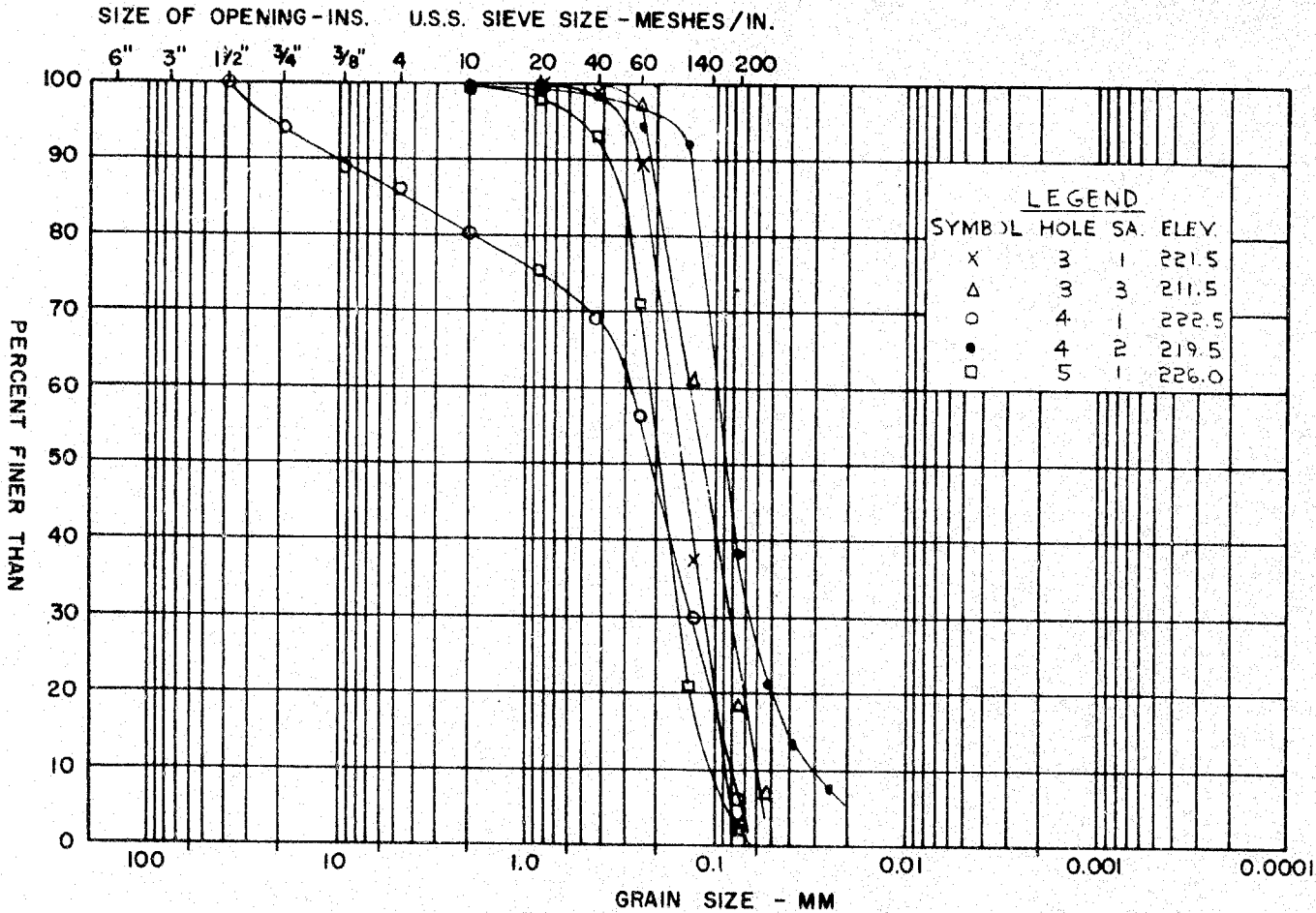

GOLDER & ASSOCIATES

GRAIN SIZE DISTRIBUTION

COBBLE SIZE	COARSE	MEDIUM	FINE	COARSE	MEDIUM	FINE	SILT SIZE	CLAY SIZE
	GRAVEL SIZE			SAND SIZE				

FIGURE 3

M.I.T. GRAIN SIZE SCALE

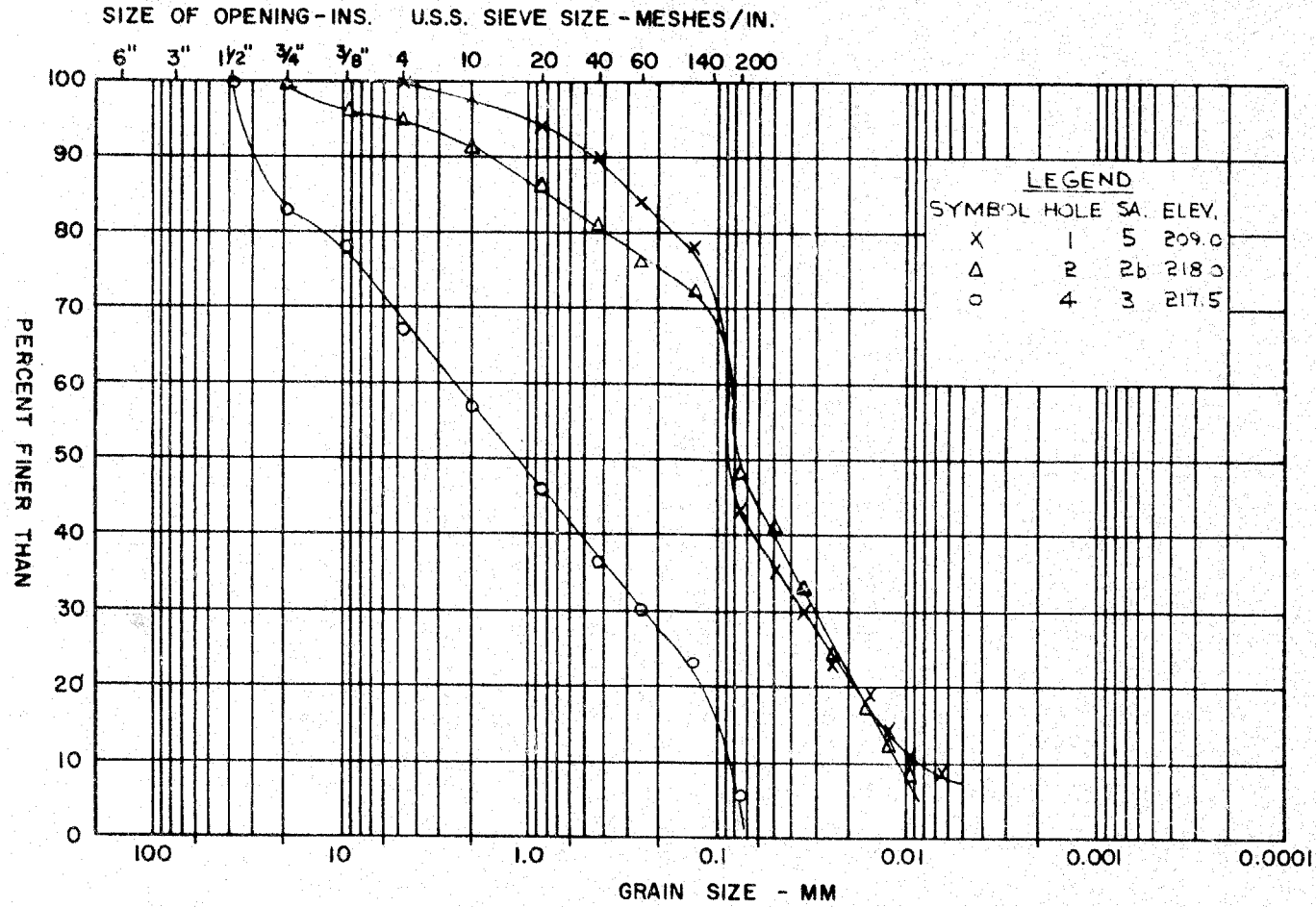

GOLDER & ASSOCIATES

GRAIN SIZE DISTRIBUTION

COBBLE SIZE	COARSE	MEDIUM	FINE	COARSE	MEDIUM	FINE	SILT SIZE	CLAY SIZE
	GRAVEL SIZE			SAND SIZE				

FIGURE 4

APPENDIX D

**Basic Chemical Analysis Results – Eurofins Report Numbers
1717833 and 1901731**

Certificate of Analysis

Client: Golder Associates Ltd. (Ottawa)
 1931 Robertson Road
 Ottawa, ON
 K2H 5B7
 Attention: Mr. Alex Meacoe
 PO#:
 Invoice to: Golder Associates Ltd. (Ottawa)

Report Number: 1717833
 Date Submitted: 2017-09-15
 Date Reported: 2017-09-20
 Project: 1655214/1130
 COC #: 823503

Lab I.D.	1320697
Sample Matrix	Soil
Sample Type	
Sampling Date	2017-09-15
Sample I.D.	17-132 sa2 3-4.5

Group	Analyte	MRL	Units	Guideline	
Agri. - Soil	pH	2.0			8.2
	SO4	0.01	%		0.06
General Chemistry	Cl	0.002	%		0.050
	Electrical Conductivity	0.05	mS/cm		1.26
	Resistivity	1	ohm-cm		794

Guideline = * = **Guideline Exceedence**
 All analysis completed in Ottawa, Ontario (unless otherwise indicated by ** which indicates analysis was completed in Mississauga, Ontario).
 Results relate only to the parameters tested on the samples submitted.
 Methods references and/or additional QA/QC information available on request.

MRL = Method Reporting Limit, AO = Aesthetic Objective, OG = Operational Guideline, MAC = Maximum Acceptable Concentration, IMAC = Interim Maximum Acceptable Concentration, STD = Standard, PWQO = Provincial Water Quality Guideline, IPWQO = Interim Provincial Water Quality Objective, TDR = Typical Desired Range

Certificate of Analysis

Client: Golder Associates Ltd. (Ottawa)
 1931 Robertson Road
 Ottawa, ON
 K2H 5B7
 Attention: Mr. Gabrielle Marcotte
 PO#:
 Invoice to: Golder Associates Ltd. (Ottawa)

Report Number: 1901731
 Date Submitted: 2019-02-05
 Date Reported: 2019-02-12
 Project: 1655214
 COC #: 840230

Group	Analyte	MRL	Units	Guideline	Lab I.D. Sample Matrix Sample Type Sampling Date Sample I.D.	1410016 Soil 2019-02-05 Phase 1220 18-2203 sa 9	1410017 Soil 2019-02-05 Phase 1220 18-2205 sa 16	1410018 Soil 2019-02-05 phase 1130 18-1301 sa 4	1410019 Soil 2019-02-05 phase 1130 18-1304 sa 2
Anions	Cl	0.002	%			0.014	0.005	0.007	<0.002
	SO4	0.01	%			0.04	0.05	0.04	0.06
General Chemistry	Electrical Conductivity	0.05	mS/cm			0.37	0.12	0.10	<0.05
	pH	2.00				8.06	7.85	8.43	8.81
	Resistivity	1	ohm-cm			2700	8330	10000	25000

Group	Analyte	MRL	Units	Guideline	Lab I.D. Sample Matrix Sample Type Sampling Date Sample I.D.	1410020 Soil 2019-02-05 phase 1130 18-1309 sa 5	1410021 Soil 2019-02-05 phase 1130 18-1311 sa 9	1410022 Soil 2019-02-05 phase 1110 18-1106 sa 5	1410023 Soil 2019-02-05 phase 1110 18-1105 sa 6
Anions	Cl	0.002	%			0.006	0.005	0.003	0.093
	SO4	0.01	%			0.06	0.03	0.04	0.10
General Chemistry	Electrical Conductivity	0.05	mS/cm			0.32	0.12	0.05	1.02
	pH	2.00				7.98	7.78	8.96	9.95
	Resistivity	1	ohm-cm			3120	8330	20000	980

Guideline = * = **Guideline Exceedence**

Results relate only to the parameters tested on the samples submitted.
 Methods references and/or additional QA/QC information available on request.

MRL = Method Reporting Limit, AO = Aesthetic Objective, OG = Operational Guideline, MAC = Maximum Acceptable Concentration, IMAC = Interim Maximum Acceptable Concentration, STD = Standard, PWQO = Provincial Water Quality Guideline, IPWQO = Interim Provincial Water Quality Objective, TDR = Typical Desired Range

APPENDIX E

**MASW Test Results and Report – Sites 3-56/1 and 3-56/2
Highway 417 Overpass at Rochester Street**

DATE December 8, 2017

PROJECT No. 1655214/1500

TO Susan Trickey
Golder Associates Ltd.

FROM Stephane Sol
Christopher Phillips

EMAIL ssol@golder.com
cphillips@golder.com

CHBDC SEISMIC SITE CLASS TESTING RESULTS – HWY417 (ROCHESTER ST EXIT) OTTAWA, ONTARIO

This technical memorandum presents the results of one Multichannel Analysis of Surface Waves (MASW) test performed for the purpose of the Canadian Highway Bridge Design Code (CHBDC 2014) Seismic Site Classification for a site located near the HWY417 off ramp to Rochester Street just east of Preston Street in Ottawa, Ontario (Figure 1). The MASW line was located on a grassy area on north of the off ramp. The geophysical testing was performed by Golder personnel on October 18, 2017.

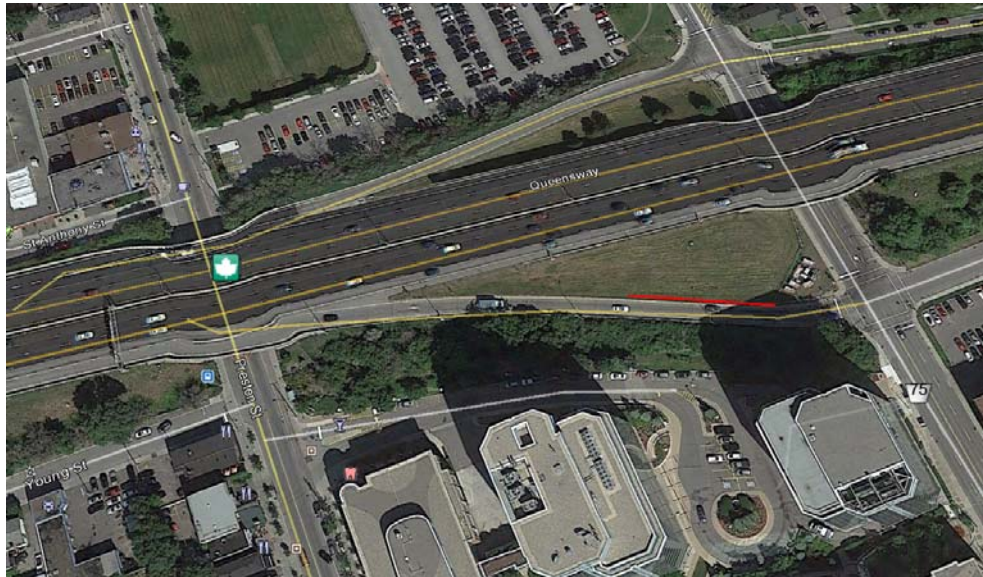

Figure 1: MASW Location Site Map (MASW Line in red)

Golder Associates Ltd.

6925 Century Avenue, Suite #100, Mississauga, Ontario, Canada L5N 7K2
Tel: +1 (905) 567 4444 Fax: +1 (905) 567 6561 www.golder.com

Golder Associates: Operations in Africa, Asia, Australasia, Europe, North America and South America

Golder, Golder Associates and the GA globe design are trademarks of Golder Associates Corporation.



Methodology

The MASW method measures variations in surface-wave velocity with increasing distance and wavelength and can be used to infer the rock/soil types, stratigraphy and soil conditions.

A typical MASW survey requires a seismic source, to generate surface waves, and a minimum of two geophone receivers, to measure the ground response at some distance from the source. Surface waves are a special type of seismic wave whose propagation is confined to the near surface medium.

The depth of penetration of a surface wave into a medium is directly proportional to its wavelength. In a non-homogeneous medium, surface waves are dispersive, i.e., each wavelength has a characteristic velocity owing to the subsurface heterogeneities within the depth interval that particular wavelength of surface wave propagates through. The relationship between surface-wave velocity and wavelength is used to obtain the shear-wave velocity and attenuation profile of the medium with increasing depth.

The seismic source used can be either active or passive, depending on the application and location of the survey. Examples of active sources include explosives, weight-drops, sledge hammer and vibrating pads. Examples of passive sources are road traffic, micro-tremors, and water-wave action (in near-shore environments).

The geophone receivers measure the wave-train associated with the surface wave travelling from a seismic source at different distances from the source.

The participation of surface waves with different wavelengths can be determined from the wave-train by transforming the wave-train results into the frequency domain. The surface-wave velocity profile with respect to wavelength (called the 'dispersion curve') is determined by the delay in wave propagation measured between the geophone receivers. The dispersion curve is then matched to a theoretical dispersion curve using an iterative forward-modelling procedure. The result is a shear-wave velocity profile of the tested medium with depth, which can be used to estimate the dynamic shear-modulus of the medium as a function of depth.

Field Work

The MASW field work was conducted on October 18, 2017, by personnel from the Golder Mississauga and Ottawa offices. For the MASW line, a series of 24 low frequency (4.5 Hz) geophones were laid out at 2 metre intervals. Both active and passive readings were recorded along the MASW line. For the active investigation, a seismic drop of 34 kg and a 9.9 kg sledge hammer were used as seismic sources. Active seismic records were collected with seismic sources located 5, 10, 15, and 20 metres from and collinear to the geophone array. An example of active seismic records collected is shown in Figure 2 below.

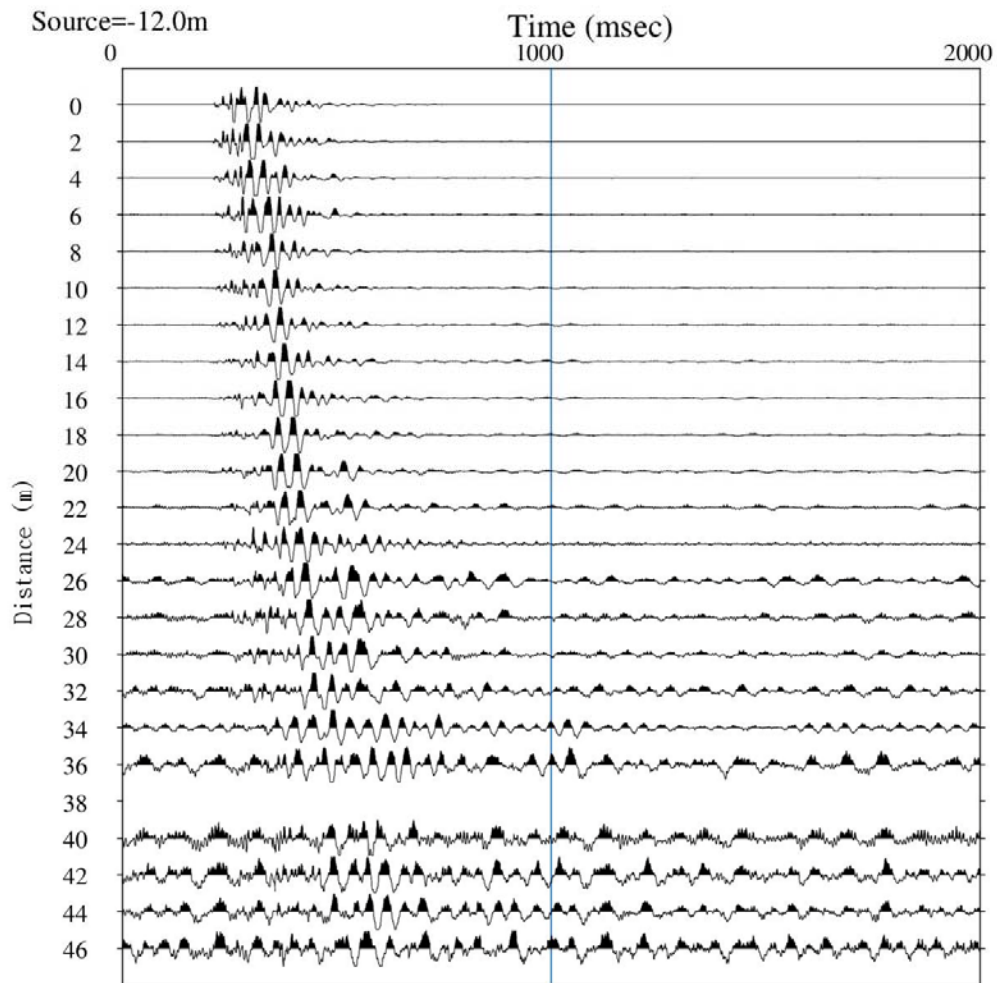

Figure 2: Typical seismic record collected along MASW Line 1

Data Processing

Processing of the MASW test results consisted of the following main steps:

- 1) Transformation of the time domain data into the frequency domain using a Fast-Fourier Transform (FFT) for each source location;
- 2) Calculation of the phase for each frequency component;
- 3) Linear regression to calculate phase velocity for each frequency component;
- 4) Filtering of the calculated phase velocities based on the Pearson correlation coefficient (r^2) between the data and the linear regression best fit line used to calculate phase velocity;
- 5) Generation of the dispersion curve by combining calculated phase velocities for each shot location of a single MASW test; and,
- 6) Generation of the stiffness profile, through forward iterative modelling and matching of model data to the field collected dispersion curve.

Processing of the MASW data was completed using the SeisImager/SW software package (Geometrics Inc.). The calculated phase velocities for a seismic shot point were combined and the dispersion curve generated by choosing the minimum phase velocity calculated for each frequency component as shown on Figure 3 and 4. Shear wave velocity profiles were generated through inverse modelling to best fit the calculated dispersion curves. The active survey provided a dispersion curve with a suitable frequency range (14 -33 Hz). The minimum measured surface wave frequency with sufficient signal-to-noise ratio to accurately measure phase velocity was approximately 14 Hz.

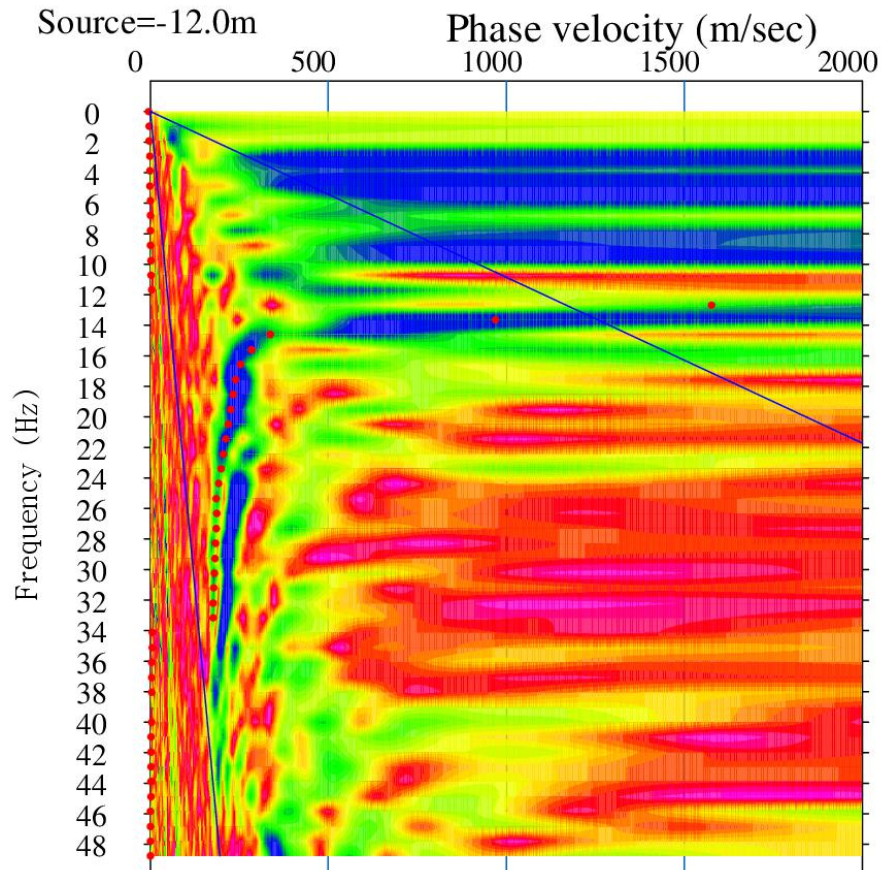

Figure 3: Active MASW Dispersion Curve Picks (red dots) along MASW Line 1

Results

The MASW test results are presented in Figure 4, which presents the calculated shear wave velocity profile derived from the field testing. The results along MASW Line 1 have been calculated using a weight-drop located at 15 m from the last geophone. The field collected dispersion curves are compared with the model generated dispersion curves on Figure 5. There is a satisfactory correlation between the field collected and model calculated dispersion curves, with a root mean squared error of less than 11%.

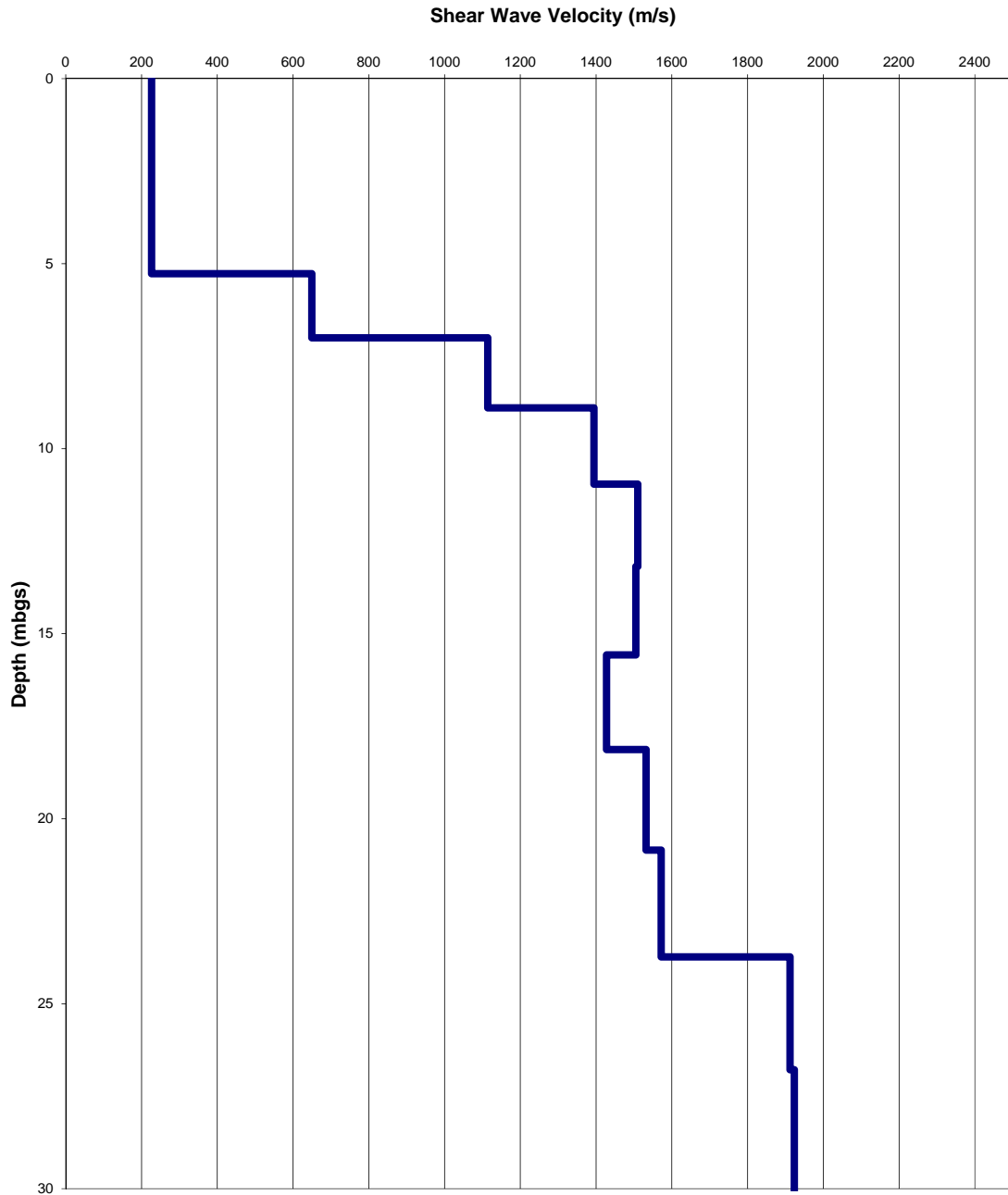

Figure 4: MASW Modelled Shear-Wave Velocity Depth profile along MASW Line 1

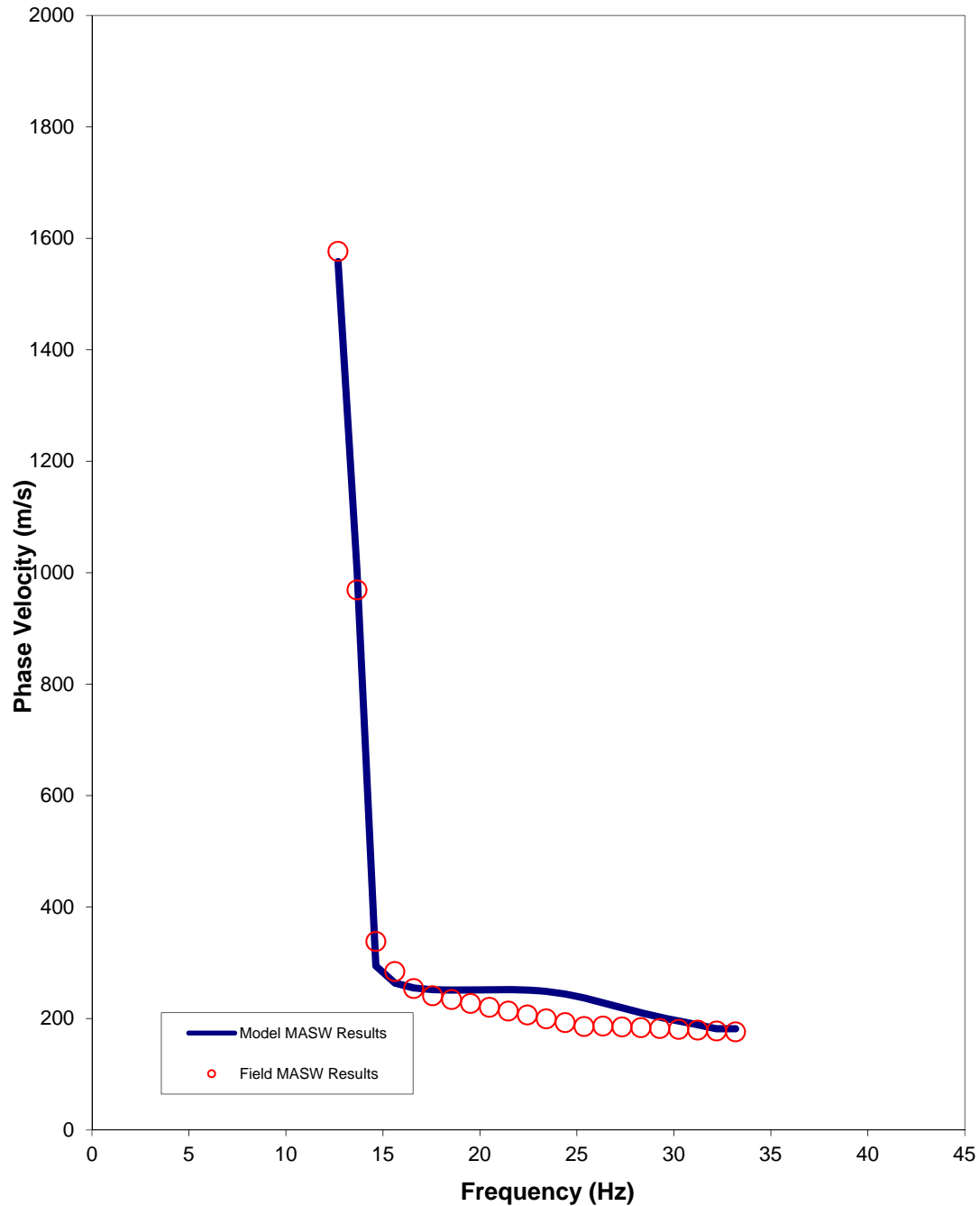

Figure 5: Comparison of Field (red dots) vs. Modelled Data (blue line) along MASW Line 1

To calculate the average shear-wave velocity as required by the Canadian Highway Bridge Design Code (CHBDC, 2014), the results were modelled to 30 metres below ground surface. The average shear-wave velocity along MASW Line 1 was found to be 734 m/s (Table 1).

The Canadian Highway Bridge Design Code (CHBDC, 2014) requires special site-specific evaluation if certain soil types are encountered on the site, so the site classification stated here should be reviewed, and modified if necessary, according to borehole stratigraphy, standard penetration resistance results, and undrained shear strength measurements, if available for this site.

Table 1: Shear-Wave Velocity Profile along MASW Line 1

Model Layer (mbgs)		Layer Thickness (m)	Shear Wave Velocity (m/s)	Shear Wave Travel Time Through Layer (s)
Top	Bottom			
0.00	1.07	1.07	226	0.004732
1.07	2.31	1.24	226	0.005460
2.31	3.71	1.40	226	0.006188
3.71	5.27	1.57	226	0.006916
5.27	7.01	1.73	650	0.002664
7.01	8.90	1.90	1114	0.001701
8.90	10.96	2.06	1395	0.001478
10.96	13.19	2.23	1510	0.001473
13.19	15.58	2.39	1505	0.001588
15.58	18.13	2.55	1428	0.001789
18.13	20.85	2.72	1532	0.001775
20.85	23.74	2.88	1572	0.001835
23.74	26.79	3.05	1912	0.001595
26.79	30.00	3.21	1924	0.001671
Vs Average to 30 mbgs (m/s)				734

Limitations

This technical memorandum, which specifically includes all tables, figures and attachments, is based on data and information collected by Golder Associates Ltd. and is based solely on the conditions of the properties at the time of the work, supplemented by historical information and data obtained by Golder Associates Ltd. as described in this memo.

Golder Associates Ltd. has relied in good faith on all information provided and does not accept responsibility for any deficiency, misstatements, or inaccuracies contained in the reports as a result of omissions, misinterpretation, or fraudulent acts of the persons contacted or errors or omissions in the reviewed documentation.

The services performed, as described in this memo, were conducted in a manner consistent with that level of care and skill normally exercised by other members of the engineering and science professions currently practicing under similar conditions, subject to the time limits and financial and physical constraints applicable to the services.

Any use which a third party makes of this memo, or any reliance on, or decisions to be made based on it, are the responsibilities of such third parties. Golder Associates Ltd. accepts no responsibility for damages, if any, suffered by any third party as a result of decisions made or actions based on this memo.

The findings and conclusions of this memo are valid only as of the date of this memo. If new information is discovered in future work, including excavations, borings, or other studies, Golder Associates Ltd. should be requested to re-evaluate the conclusions of this memo, and to provide amendments as required.

Closure

We trust that this technical memorandum meets your needs at the present time. If you have any questions or require clarification, please contact the undersigned at your convenience.

GOLDER ASSOCIATES LTD.

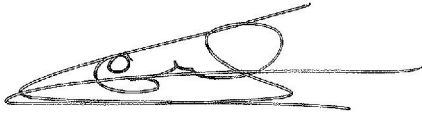

Stephane Sol, Ph.D, P. Geo.
Senior Geophysicist



Christopher Phillips, M. Sc., P. Geo.
Senior Geophysicist, Principal

SS/CRP/mvrd

n:\active\2016\3 proj\1655214 mto 4016-e-0001hwy 417 ottawa\foundations\3 - field work\geophysics\1655214_1500 mto\preston\report\1655214_1500 masw tech memo preston2017_8dec2017.docx

APPENDIX F

Site Photographs



Photograph 1: Looking north along Bronson Avenue towards the Highway 417 Overpass at Bronson Avenue 2019-03-13



Photograph 2: Looking south towards the Highway 417 Overpass at Bronson Avenue 2019-03-13



**Photograph 3: Looking southwest towards existing northeast retaining wall east of east abutment
2019-03-13**



**Photograph 4: Looking southwest towards existing northwest retaining wall west of west abutment
2019-03-13**



Photograph 5: Looking west towards the southwest embankment 2019-03-13



Photograph 6: Looking north towards the southeast retaining wall 2019-03-13



golder.com