

FINAL REPORT

Foundation Investigation Highway 417 Overpass Structures at Booth Street Rapid Bridge Replacement Ottawa, Ontario

Site Nos. 3-57/1 and 3-57/2

G.W.P. 4173-15-00

W.P. 4126-11-01 & 4215-15-01

Submitted to:

WSP Canada Group Limited

300-2611 Queensview Drive

Ottawa, Ontario

K2B 8K2

Submitted by:

Golder Associates Ltd.

1931 Robertson Road, Ottawa, Ontario, K2H 5B7, Canada

GEOCREs No. 31G5-308

1655214-1120

Latitude: 45.403689°

Longitude: -75.707079°

July 2019



Distribution List

4 copies - MTO

2 e-copies - MTO

1 e-copy - WSP Canada Group Limited

1 e-copy - Golder

Table of Contents

PART A – FOUNDATION INVESTIGATION

1.0 INTRODUCTION	1
2.0 SITE DESCRIPTION AND GEOLOGY	1
2.1 Site Description	1
2.2 Regional Geology	2
3.0 INVESTIGATION PROCEDURES	2
3.1 Current Investigations (2017 and 2018)	2
3.2 Previous Investigation (1959)	8
4.0 DESCRIPTION OF SUBSURFACE CONDITIONS	8
4.1 General	8
4.2 Site Stratigraphy Overview	9
4.3 Highway 417 Approach Embankments	9
4.3.1 Surface Cover / Surficial Materials	9
4.3.2 Pavement Structure and Embankment Fills	9
4.3.3 Glacial Till	10
4.4 Booth Street	10
4.4.1 Surface Cover	10
4.4.2 Sand, Gravely Sand, and Sand and Gravel Fill	10
4.5 Staging Areas	10
4.5.1 Surface Cover	10
4.5.2 Fill	10
4.6 Concrete Footings	11
4.7 Bedrock	11
4.8 Groundwater Conditions	13
4.9 Steel Corrosion and Sulphate Attack, Chemical Analysis	13
5.0 CLOSURE	14

Table of Contents

PART A – FOUNDATION INVESTIGATION

TABLES EMBEDDED WITHIN REPORT

Table 1: Summary of Corehole/Drillhole Locations	5
Table 2: Summary of Borehole Locations	6
Table 3: Summary of Bedrock Surface Depths and Elevations	11
Table 4: Summary of Groundwater Conditions	13
Table 5: Steel Corrosion and Sulphate Attack, Chemical Analysis	13

DRAWINGS

Drawings 1 to 4 – Highway 417 Overpass Structures at Booth Street, Borehole Locations and Soil Strata
 Drawing 5 – Highway 417 Overpass Structures at Booth Street, Staging Areas, Borehole Locations and Soil Strata

APPENDICES

APPENDIX A

Lists of Abbreviations and Symbols
 Lithological and Geotechnical Rock Description Terminology
 Record of Coreholes/Drillholes 17-B01 to 17-B24
 Record of Boreholes 17-121 to 17-124
 Record of Boreholes 18-1201 to 18-1213
 Bedrock Core Photographs, Figures A1 to A31
 Table A1 - Concrete Core Condition Assessment

APPENDIX B

Laboratory Test Results, Current Investigation

Figure B1 – Grain Size Distribution Test Results – Sand to Silty Sand - Fill
 Figure B2 – Grain Size Distribution Test Results – Sand - Fill
 Figure B3 – Grain Size Distribution Test Results – Sandy Clayey Silt - Fill
 Figure B4 – Grain Size Distribution Test Results – Gravelly Silty Sand Trace Clay - Till
 Figure B5 – Grain Size Distribution Test Results – Sand, Gravelly Sand, and Sand and Gravel - Fill
 Figure B6 – Grain Size Distribution Test Results – Sand and Gravel - Fill
 Figure B7 – Summary of Laboratory Compressive Strength Unconfined Compression Tests

APPENDIX C

Previous Investigations, GEOCRETS 31G05-030 (1959)

Soil Profile & Laboratory Tests Sheets No. 1 to 7
 Test Boring Plan

APPENDIX D

Results of Chemical Analysis Eurofins Environment Testing Report No. 1706532

APPENDIX E

MASW Test Results and Report

Sites 3-56/1 and 3-56/2 Highway 417 Overpass at Rochester Street

APPENDIX F

Site Photographs

PART A

Foundation Investigation
Highway 417 Overpass Structures at Booth Street
Rapid Bridge Replacement
Ottawa, Ontario

1.0 INTRODUCTION

Golder Associates Ltd. (Golder) has been retained by WSP Canada Group Limited (WSP) on behalf of the Ministry of Transportation, Ontario (MTO) to carry out foundation investigations associated with the detailed design of numerous bridge replacements, overhead signs, noise barrier walls, temporary roadway protection systems, replacement of storm sewers (including trenchless crossings) and a high fill embankment on Highway 417 between Island Park Drive and Kent Street in Ottawa, Ontario (Assignment number 4016-E-0001).

This report presents the results of the foundation investigation carried out for the rapid bridge replacement (RBR) and widening of the Highway 417 eastbound (Site 3-57/1) and westbound (Site 3-57/2) overpass structures at Booth Street (G.W.P. 4173-15-00 and W.P. 4126-11-01 and W.P. 4215-15-01). The replacement of the structures is to be carried out in accordance with the current version of the Canadian Highway Bridge Design Code, S6-14 (CHBDC).

The terms of reference and scope of work for the foundation investigation are outlined in the MTO's Request for Proposal, dated April 2016, and subsequent addenda. Golder's scope of work for foundation engineering services associated with the Highway 417 Overpasses at Booth Street is contained in Table 17.8.3 of WSP's Technical Proposal for this assignment dated June 28, 2016. The work has been carried out in accordance with Golder's Quality Control Plan for foundation engineering services for the project dated August 29, 2016.

2.0 SITE DESCRIPTION AND GEOLOGY

2.1 Site Description

Sites 3-57/1 and 3-57/2 are located at Station 27+370, approximately 460 m east of the O-Train Trillium Line, within the City of Ottawa. The location of the overpass structures is shown on the Key Plan on Drawings 1 through 5. Site photographs showing the general conditions at the site are presented in Appendix F.

At this location, Highway 417 is a divided highway with four travel lanes in each direction separated by a concrete barrier wall. The westbound speed change lane of the Highway 417 / Bronson Avenue Interchange ends approximately 15 m east of Site 3-57/2.

Each of the existing structures is a single-span concrete rigid frame bridge that is supported on shallow foundations founded directly on bedrock. Information provided in the RFP indicates that the structures were built in 1962. The structures have a clear span of 18.3 m measured perpendicular to the abutments and are separated from each other by a longitudinal joint. The average overall deck width of each structure, measured perpendicular to the centerline of the highway, is approximately 20.6 m. Each abutment has two retaining walls located along the north and south sides of the highway embankment for retaining the embankment fill. Noise barriers are installed on concrete barriers on the north side of Highway 417 and carried through the entire length of the structures. There is a 1.2 m diameter watermain located just south of the eastbound structure which runs parallel to the highway.

The existing approach embankments are about 6 m to 7 m high relative to the elevation of Booth Street, with side slopes oriented at approximately 2 horizontal to 1 vertical (2H:1V). Based on a visual observation at the time of the site investigation, no signs of foundation settlement were observed, and the existing embankment slopes appear to be performing satisfactorily. There is an existing retaining wall located at the toe of the northeast highway embankment that runs parallel to Raymond Street.

2.2 Regional Geology

As delineated in *The Physiography of Southern Ontario*¹, this section of Highway 417 lies within the minor physiographic region known as the Ottawa Valley Clay Plain, which is within the major physiographic region of the Ottawa-St. Lawrence Lowland.

The Ottawa Valley Clay Plain region is characterized by relatively thick deposits of sensitive marine clay, silt and silty clay that were deposited within the former Champlain Sea basin. These deposits, known as the Champlain Sea clay or Leda clay, overlie relatively thin, commonly reworked glacial till and glaciofluvial deposits, that in turn overlie bedrock².

This region is underlain by a series of sedimentary rocks, consisting of sandstones, dolostones, limestones and shales that are, in turn, underlain at depth by igneous and metamorphic bedrock of the Precambrian Shield. Regional bedrock mapping indicates that the bedrock at this site is primarily limestone of the Verulam Formation.³ The limestone is described as interbedded bioclastic, sublithographic to fine crystalline with very thin to medium bedded shale interbeds up to 8 cm thick. Bedrock outcrops are mapped north and south of the Highway 417 / Bronson Avenue Interchange.

The site lies between two faults striking southeast to northeast. The more prominent fault, the Gloucester fault, crosses Highway 417 at the approximate location of Preston Street.⁴ The second fault crosses Highway 417 some 300 m east. Bedding which is normally sub-horizontal often dips steeply adjacent to and within fault zones.

The site falls within the Western Québec (WQ) seismic zone according to the Geological Survey of Canada. The WQ zone constitutes a large area which encompasses the urban areas of Montreal, Ottawa-Hull and Cornwall. Within the WQ zone recent seismic activity has been concentrated in two subzones; one along the Ottawa River and another more active subzone along the Montreal-Maniwaki axis. The two major earthquakes that have recently occurred in the WQ zone are the 1935 Témiscaming event, which had a magnitude (i.e., a measure of the intensity of the earthquake) of 6.2, and the 1944 Cornwall-Massena event, which had a magnitude of 5.6.

3.0 INVESTIGATION PROCEDURES

3.1 Current Investigations (2017 and 2018)

The field work for the 2017 investigation was carried out between March 20 and April 10, 2017 and included advancing a total of 24 coreholes, designated as 17-B01 to 17-B24, and four boreholes, designated as 17-121 to 17-124, located along Booth Street.

A supplemental investigation was carried out between October 2 and 11, 2018 and April 10 and 15, 2019, that included advancing eight additional boreholes located along the approach and highway embankments, designated as 18-1201 to 18-1208.

¹ Chapman, L. J. and Putnam, D. F., 1984. *The Physiography of Southern Ontario*, Ontario Geological Survey. Special Volume 2, Third Edition. Accompanied by Map P.2715, Scale 1:600,000. Ontario Ministry of Natural Resources

² Belanger, J.R. "Urban Geology of Canada's National Capital Area", in *Urban Geology of Canadian Cities*, Geological Association of Canada Special Paper 42, Ed. P.F. Karrow and O.L. White, 1998.

³ Williams, D.A. Rae, A.M., and Wolf, R.R. 1984: Paleozoic Geology of the Ottawa Area, Southern Ontario, Ontario Geological Survey, Map P.2716. Geological Series-Preliminary Map, scale 1:50,000. Geology 1982.

⁴ MacDonald, G. and Harrison, J.E. 1976: Generalized Bedrock Geology, Ottawa-Hull, Ontario and Quebec, Geological Survey of Canada, Map 1508A, scale 1:125,000. Geology 1967.

Five additional boreholes were also advanced as part of the investigation for the proposed staging areas for this project. These included Boreholes 18-1212 and 18-1213, which were advanced on November 19, 2018, and Boreholes 18-1209 to 18-1211, which were advanced on January 27, 2019.

Tables 1 and 2 further outline the location of the testholes with respect to the existing structures and staging areas.

The 24 coreholes (12 per abutment) were drilled at approximately 3 m spacing along Booth through the existing sidewalks using portable drilling equipment and were then subsequently hydro-excavated to expose the top of the existing footings. Eight of the coreholes (four per abutment) were further advanced into the underlying bedrock to form Drillholes 17-B01D, 17-B04D, 17-B08D, 17-B12D, 17-B13D, 17-B16D, 17-B20D, and 17-B24D. Following the vertical hydro-excavation all drillholes except for 17-B04 were drilled on an incline due to the proximity of their location to the adjacent abutment and existing utilities. The angle of inclination is indicated on the Record of Drillholes and is relative to the horizontal, with an azimuth perpendicular to the abutments.

Boreholes 17-121 to 17-124 were located on Booth Street to the north and south of the existing abutments, while Boreholes 18-1201 to 18-1204 were advanced through the existing Highway 417 embankments. Boreholes 18-1205 to 18-1208 were located within the highway approach embankments behind the existing abutments. Boreholes 18-1209 to 18-1213 were advanced at the proposed staging areas located in the existing parking lots south of Orangeville Street, to the east and west of Booth Street.

Boreholes 17-121 to 17-124 and Boreholes 18-1205 to 18-1213 were advanced using a combination of truck-mounted drilling and hydro-excavation equipment. The drilling equipment was supplied and operated by CCC Geotechnical & Environmental Drilling Ltd. of Ottawa, Ontario.

Boreholes 18-1201 to 18-1204 were advanced with portable rotary drilling equipment using NW and HW sized casing due to the proximity of the borehole locations to the adjacent abutment wingwalls and embankment slopes. The drilling equipment used a full weight hammer, but was dropped from a reduced height of 0.61 m. Where the reduced drop height was used, the N values presented on the Record of Boreholes are “uncorrected” and should be interpreted in consideration of their reduced penetration energy. This equipment was supplied and operated by Marathon Underground Constructors Corporation of Greely, Ontario.

Traffic control, required to close either the driving lanes of Highway 417 or Booth Street while carrying out field operations, was provided by Beacon Lite Ltd. of Ottawa, Ontario.

Grab samples of the overburden were recovered from within the hydro-excavations carried out at the coreholes and Boreholes 17-123 and 17-124. Soil samples in Boreholes 17-121 and 17-122 and Boreholes 18-1201 to 18-1204 were obtained at vertical sampling intervals of about 0.6 m, using a 50 mm outer diameter split-spoon sampler in general accordance with the Standard Penetration Test (SPT) procedure (ASTM D1586). Soil samples from boreholes advanced with truck-mounted drilling equipment (Boreholes 18-1205 to 18-1213) were obtained at vertical intervals of about 0.76 m, also in accordance with ASTM D1586.

Concrete and bedrock core samples were obtained in the drillholes using BQ sized equipment. Concrete and bedrock core samples were obtained in Boreholes 18-1201 to 18-1204 using a combination of NQ and HQ sized equipment.

Monitoring wells were installed in Boreholes 17-121, 17-124, and 18-1207, to observe the stabilised groundwater across the site. The monitoring wells consist of 32 mm outside diameter PVC tubing with a 1.5 m long slotted tip.

The final groundwater levels were measured in the wells on October 27, 2017 (Boreholes 17-121 and 17-124) and December 6, 2018 (Borehole 18-1207) and then the wells were decommissioned according to Ontario MOE Regulation 903 (O.Reg 903) by a licenced well technician.

Where cored, the holes advanced through the existing footings and bedrock were grouted following completion of the work. The coreholes/drillholes were then backfilled with granular material above the existing footing level to the underside of the existing sidewalk, then capped with concrete. The boreholes were backfilled with bentonite within the bedrock, and bentonite mixed with soil cuttings within the overburden. The boreholes were then capped with either concrete sidewalk patch or asphaltic concrete cold patch, depending on the surrounding surface cover. The boreholes were backfilled in general accordance with the intent of O.Reg 903, as amended. The site conditions were restored following completion of the field work.

The field work was supervised on a full-time basis by members of Golder's staff who located the testholes in the field, directed the drilling, sampling, and in-situ testing operations, logged the testholes and examined and cared for the samples. The soil and bedrock samples were identified in the field, placed in labelled containers, and transported to Golder's laboratory in Ottawa for further examination and testing. Index and classification tests consisting of water content determinations and grain size distribution analyses were carried out on selected soil samples at Golder's Ottawa laboratory. Unconfined compressive strength testing was carried out on select samples of the bedrock at Golder's Mississauga laboratory. The laboratory tests were carried out to MTO and/or ASTM Standards, as appropriate.

One soil sample from Borehole 17-122 was submitted to Eurofins Environment Testing for chemical analysis related to potential corrosion of exposed buried steel and potential sulphate attack on buried concrete elements (corrosion and sulphate attack).

In addition to the borehole investigations at the current sites, shear wave velocity profiling was completed at the nearby Highway 417 Overpass Structures at Rochester Street (Sites 3-56/1 and 3-56/2), located approximately 130 m west of Booth Street. Due to the close proximity and similar nature of the surficial and bedrock geology of the sites, the profiles developed at Rochester Street (Sites 3-56/1 and 3-56/2) are considered relevant to the current structures.

The shear wave velocity profiling was carried out in the grassy area next to the eastbound E-N/S off-ramp of the Highway 417 / Rochester Street Interchange, just west of Rochester Street, using the Multichannel Analysis of Surface Waves (MASW) technique. The MASW profiling was carried out on October 18, 2017, by personnel from Golder's Mississauga and Ottawa offices. A series of low frequency (4.5 Hz) geophones were laid out at 2 m intervals. A 9.9 kg sledgehammer and 34 kg drop weight were used as the seismic source. The source locations were offset at various distances beyond the end and collinear with the geophone array.

The testhole locations and elevations were surveyed by Golder using a Trimble R8 GPS unit referenced to the NAD83 CSRS CBNv6-2010.0 MTM Zone 9 geodetic datum. The testhole locations, including northing and easting coordinates, ground surface and top of existing abutment footing elevations, and drilled/cored depths are summarized in Tables 1 and 2.

Table 1: Summary of Corehole/Drillhole Locations

Corehole/ Drillhole ¹	Location	NAD83 CSRS CBNv6 2010.0 MTM Zone 9		Ground Surface Elevation (m)	Testhole Inclination ² (°)	Top of Existing Footing Elevation ³ (m)	Footing Thickness (m)	Corehole/ Drillhole Depth ⁴ (m)
		Northing (m)	Easting (m)					
17-B01/D	Sidewalk on Booth Street at east abutment	5029629.0	366875.9	66.4	88	65.7	0.9	2.4
17-B02		5029624.8	366877.7	66.4	Vertical	65.7	-	0.7
17-B03		5029622.2	366879.0	66.4	Vertical	65.7	-	0.7
17-B04/D		5029619.4	366880.2	66.4	Vertical	65.7	1.0	2.5
17-B05		5029616.6	366881.4	66.4	Vertical	65.7	-	0.7
17-B06		5029613.8	366882.6	66.4	Vertical	65.7	-	0.7
17-B07		5029611.1	366883.8	66.5	Vertical	65.9	-	0.6
17-B08/D		5029608.5	366884.9	66.5	84	65.9	1.0	2.2
17-B09		5029605.6	366886.2	66.5	Vertical	65.9	-	0.6
17-B10		5029602.8	366887.4	66.5	Vertical	65.9	-	0.6
17-B11		5029600.1	366888.6	66.6	Vertical	65.9	-	0.7
17-B12/D		5029597.1	366889.9	66.6	Vertical	65.9	0.9	2.6
17-B13/D		Sidewalk on Booth Street at west abutment	5029591.2	366873.2	66.6	77	65.8	1.0
17-B14	5029594.3		366871.9	66.6	Vertical	65.8	-	0.8
17-B15	5029597.4		366870.5	66.6	Vertical	65.8	-	0.8
17-B16/D	5029600.5		366869.2	66.5	77	65.8	1.1	2.3
17-B17	5029603.4		366867.9	66.5	Vertical	65.8	-	0.7
17-B18	5029606.6		366866.5	66.4	Vertical	65.8	-	0.6
17-B19	5029609.9		366865.1	66.4	Vertical	65.7	-	0.7
17-B20/D	5029612.6		366863.9	66.4	78	65.7	1.1	2.4
17-B21	5029615.6		366862.6	66.4	Vertical	65.7	-	0.7
17-B22	5029618.7		366861.3	66.3	Vertical	65.7	-	0.6
17-B23	5029621.8		366859.9	66.3	Vertical	65.7	-	0.6
17-B24/D	5029624.3	366858.8	66.3	69	65.7	0.9	2.3	

Notes: ¹ B = Corehole only; B/D = Combination Corehole and Drillhole

² Testhole inclination is measured counter-clockwise from the vertical

³ Top of footing elevation shown is measured vertically from the ground surface

⁴ Depth indicated is measured along the drill path

Table 2: Summary of Borehole Locations

Borehole ¹	Location	NAD83 CSRS CBNv6-2010.0 MTM Zone 9		Ground Surface Elevation (m)	Top of Existing Footing Elevation (m)	Footing Thickness (m)	Drilled Length (m)
		Northing (m)	Easting (m)				
17-121	Booth Street West Sidewalk South of west abutment	5029588.1	366875.8	66.6	N/A	N/A	4.1
17-122	Booth Street East Sidewalk South of east abutment	5029591.2	366891.0	66.7			4.2
17-123	Booth Street West Sidewalk North of west abutment	5029627.2	366858.8	66.3			4.8
17-124	Booth Street East Sidewalk North of east abutment	5029631.8	366873.5	66.4			4.4
18-1201	Highway 417 Embankment Northwest of west abutment	5029623.2	366850.6	68.4	65.5	0.9	5.6
18-1202	Highway 417 Embankment Southwest of west abutment	5029588.0	366868.8	69.5	66.7	1.0	5.7
18-1203	Highway 417 Embankment Northeast of east abutment	5029632.6	366880.7	68.7	66.1	1.1	5.5
18-1204	Highway 417 Embankment Southeast of east abutment	5029597.6	366900.1	70.5	66.2	1.0	7.1
18-1205	Highway 417 Westbound west of west abutment	5029618.3	366850.1	71.9	N/A	N/A	6.9
18-1206	Highway 417 Eastbound west of west abutment	5029601.2	366853.7	72.1			6.9

Borehole ¹	Location	NAD83 CSRS CBNv6-2010.0 MTM Zone 9		Ground Surface Elevation (m)	Top of Existing Footing Elevation (m)	Footing Thickness (m)	Drilled Length (m)		
		Northing (m)	Easting (m)						
18-1207	Highway 417 Westbound East of east abutment	5029618.2	366891.1	72.6	N/A	N/A	6.9		
18-1208	Highway 417 Eastbound East of east abutment	5029602.4	366898.5	72.9			7.6		
18-1209	Staging Area 1 Southwest of eastbound structure South of Orangeville Street	5029514.3	366806.2	65.3			1.0		
18-1210	Staging Area 1 Southwest of eastbound structure South of Orangeville Street	5029529.9	366838.3	66.0			1.0		
18-1211	Staging Area 1 Southwest of eastbound structure South of Orangeville Street	5029545.2	366884.1	66.8			1.6		
18-1212	Staging Area 2 Southeast of eastbound structure South of Orangeville Street	5029556.0	366916.4	67.2			N/A	N/A	1.6
18-1213	Staging Area 2 Southeast of eastbound structure South of Orangeville Street	5029572.0	366933.6	67.8					1.4

Note: ¹ All boreholes were drilled vertically with an inclination of 90°

3.2 Previous Investigation (1959)

A previous investigation was carried out for the design of the existing structures in 1959. The subsurface information and results of the original investigation are contained in the report titled:

- “*Report of Soil Investigation Site of Bridge No. 17, at Booth Street, the Queensway, For De Leuw, Cather & Company of Canada, Limited, Consulting Engineers, Report No. S-108-59, W.P. 941-59*”, dated December 9, 1959 (GEOCREC No. 31G05-030).

As part of the current assignment, previously collected subsurface information pertinent to the site was reviewed and compiled.

A total of seven boreholes were advanced at the site as part of the original investigation along the then proposed bridge alignment over Booth Street. The Soil Profile and Laboratory Test Sheets from the previous investigation are provided for reference in Appendix C. The approximate borehole locations and ground surface elevations are shown on Drawings 1 and 2.

The locations of the previous boreholes should be considered approximate since the locations were referenced to an imperial borehole location plan rather than metric MTM coordinates. Further, the boreholes from the previous investigation were advanced prior to construction of the bridge and the ground surface conditions shown may not be representative of the post-construction subsurface conditions, particularly with respect to the composition and thickness of overburden and fill. It is also unknown if the surface of the bedrock as encountered in the 1959 investigation was altered during construction of the overpass structure. Therefore, the stratigraphy encountered in the 1959 boreholes was not included in the stratigraphic profiles shown on Drawings 1 and 2.

4.0 DESCRIPTION OF SUBSURFACE CONDITIONS

4.1 General

The subsurface soil, bedrock and groundwater conditions encountered in the testholes and the results of in-situ testing from the current investigation are given on the Record of Borehole, Corehole, and Drillhole sheets presented in Appendix A. The results of the laboratory testing carried out during the current investigation are presented on the Record of Borehole sheets as well as on Figures B1 to B6 in Appendix B. The borehole locations and the interpreted stratigraphic profile projected along each abutment and staging area are provided on Drawings 1 to 5.

Photographs of the core recovered from the concrete footings and underlying bedrock are shown on Figures A1 to A31 provided in Appendix A. An assessment of the condition of the Portland Cement Concrete (PCC) footing cores is provided in Table A1 of Appendix A. The results of basic chemical analysis completed on select soil samples are provided in Appendix D.

The MASW test results and report from Sites 3-56/1 and 3-56/2 are presented in Appendix E and include the calculated shear wave velocity profile measured from the field testing and a graphical representation of the shear wave velocity profile with depth for those sites.

The stratigraphic boundaries shown on the testhole sheets and on the interpreted stratigraphic sections from Drawings 1 to 5, are inferred from observations of drilling progress and noncontinuous sampling and therefore, represent transitions between soil types rather than exact planes of geological change. The subsoil conditions will vary between and beyond the borehole locations.

4.2 Site Stratigraphy Overview

In general, the subsurface conditions at the testhole locations advanced along Booth Street consist of PCC sidewalk at surface, overlying granular fill overlying PCC footings and/or limestone bedrock.

At the approach boreholes the subsurface conditions consist of asphaltic concrete/Portland cement concrete surface cover, overlying fill materials, overlying native glacial till all underlain by limestone bedrock. Due to the age of the structures, it is possible that remnants of temporary works abandoned after construction of the existing structure may be buried in the fill.

At the embankment boreholes, the subsurface conditions consist of topsoil surface cover, overlying fill materials, overlying granular fill overlying PCC footing all underlain by limestone bedrock.

At the staging area boreholes, the subsurface conditions consist of asphaltic concrete surface cover, overlying fill materials, overlying native glacial till, all underlain by limestone bedrock.

The groundwater levels measured at the site at depths range from 2.2 to 6.9 m in depth, corresponding to Elevations 64.1 to 65.7 m.

A more detailed description of the overburden soil deposits, concrete footings, bedrock geology and groundwater conditions encountered during the field investigation is provided in the following sections.

4.3 Highway 417 Approach Embankments

4.3.1 Surface Cover / Surficial Materials

Boreholes 18-1205 to 18-1208 were advanced through the Highway 417 pavement structure. The thickness of the asphaltic concrete at the borehole locations ranges from 200 to 300 mm.

PCC was encountered below the asphaltic concrete in Boreholes 18-1205 and 18-1208 and is 300 mm in thickness.

4.3.2 Pavement Structure and Embankment Fills

Pavement structure fill consisting predominantly of sand and gravel was encountered below the asphaltic concrete in Boreholes 18-1206 and 18-1207 and below the PCC at Boreholes 18-1205 and 18-1208. The top of this layer was encountered at elevations ranging from 71.4 to 72.5 m. The thickness of the fill ranges from 300 to 600 mm.

Fill consisting predominantly of sand with varying amounts of silt and gravel was encountered at the ground surface at embankment Boreholes 18-1201 to 18-1204 and below the pavement structure at approach Boreholes 18-1205 to 18-1208. The top of this layer was encountered at elevations ranging from 68.4 to 72.1 m. The thickness of the fill ranges from 2.6 to 6.8 m. The SPT N values ranged from 4 to 91, indicating a loose to very dense state of packing, but more typically dense to very dense. The measured moisture content of the samples tested ranged from 5 to 10 percent. The results of grain size analysis testing carried out on nine samples of this material are provided on Figures B1 and B2 in Appendix B.

A sandy clayey silt fill was encountered in Boreholes 18-1206 and 18-1208 at elevations of 70.9 and 67.6 m respectively. The clayey silt fill at Borehole 18-1206 contains ash, asphalt debris and organic matter. The thickness of the silt fill at these locations was 0.2 and 0.6 m. One SPT N value of 2 was recorded in the clayey silt at Borehole 12-1208, indicating a firm state of packing. The measured moisture content of the two samples tested

of the clayey silt fill was 17 and 20 percent. The results of a grain size analysis test carried out on a single sample of this material are provided on Figure B3 in Appendix B.

4.3.3 Glacial Till

Glacial till was encountered below the fill in Borehole 18-1207. The glacial till generally consists of a heterogeneous mixture of cobbles within a soil matrix of sand and gravel. The till is classified as a gravelly sand some silt trace clay. This layer was encountered at Elevation 66.5 m and is about 800 mm in thickness.

One SPT N value of 6 was recorded in the till, indicating a loose state of packing. The higher blow count (i.e., 60) noted on the Record of Borehole may have been influenced by the underlying bedrock surface or the presence of cobbles or boulders within the till, rather than the state of packing of the soil matrix.

The measured moisture content of a single sample of the glacial till was 29 percent. The results of grain size distribution testing carried out on a single sample of the glacial till are provided on Figures B4 Appendix B.

4.4 Booth Street

Boreholes 17-121 to 17-124 and the coreholes/drillholes 17-B01 to 17-B24 were advanced within the Booth Street right-of-way along the existing abutments.

4.4.1 Surface Cover

A PCC sidewalk was encountered at the ground surface at Boreholes 17-121 to 17-124 and the coreholes/drillholes advanced along Booth Street. The thickness of the concrete ranges from 100 to 200 mm at the testhole locations.

4.4.2 Sand, Gravelly Sand, and Sand and Gravel Fill

A fill consisting predominantly of sand with varying amounts of silt and gravel was encountered below the PCC sidewalk at all testhole locations. The top of this layer was encountered at elevations ranging from 66.1 to 66.6 m. The thickness of the layer ranges from 0.4 to 1.0 m. The SPT N values ranged from 11 to 13, indicating a compact state of packing.

The moisture content of the samples tested ranged from 9 to 13 percent. The results of grain size analysis tests carried out on six samples of this material are provided on Figure B5 in Appendix B.

4.5 Staging Areas

Boreholes 18-1209 to 18-1211 were advanced within Staging Area 1 and Boreholes 18-1212 and 18-1213 were advanced within Staging Area 2. The locations of the staging areas are shown on the plan view on Drawing 5.

4.5.1 Surface Cover

Asphaltic concrete was encountered at the ground surface of all boreholes advanced within the staging areas.

The thickness of the asphaltic concrete at the borehole locations in Staging Area 1 ranges from 40 to 50 mm, while in Staging Area 2 the thickness ranges from 70 to 80 mm.

4.5.2 Fill

A fill consisting predominantly of sand and gravel with varying amounts of silt was encountered below the asphaltic concrete at all boreholes advanced in the staging areas. The top of this layer was encountered at

elevations ranging from 65.2 to 67.7 m. The thickness of the layer ranges from 0.95 to 1.6 m. The measured SPT N values ranged from 31 to 36, indicating a dense state of packing.

The measured moisture content of the five samples tested ranged from 3 to 8 percent. The results of a grain size analysis test carried out on a single sample of this material are provided on Figure B6 in Appendix B.

4.6 Concrete Footings

The existing concrete footings were encountered in coreholes/drillholes 17-B01 to 17-B24 and embankment Boreholes 18-1201 to 18-1204. The top of the concrete footing was encountered at elevations ranging from 66.7 to 65.5 m. The thickness of the footings ranges from 0.9 to 1.1 m, as indicated by coring through the existing footing to the underlying bedrock. Tables 1 and 2 in Section 3.1 provide the top of footing elevation and footing thickness at each of the drillhole locations and at Boreholes 18-1201 to 18-1204. An assessment of the condition of the PCC footing cores is provided in Table A1 of Appendix A.

4.7 Bedrock

The overburden and concrete footings are underlain by limestone bedrock with shale partings and interbeds. Regional bedrock mapping indicates that the bedrock at this site is primarily limestone of the Verulam Formation.

Bedrock was proven by coring using NQ sized equipment in Boreholes 17-121 to 17-124 and NQ and HQ sized equipment in Boreholes 18-1201 to 18-1204. Bedrock was proven by coring using BQ sized equipment in Drillholes 17-B01/D, 17-B04/D, 17-B08/D, 17-B12/D, 17-B13/D, 17-B16/D, 17-B20/D, and 17-B24/D. Photographs of the bedrock core are provided in Appendix A. Bedrock was also proven by coring using BX sized coring equipment in Boreholes 1 to 7 during the 1959 investigation.

Table 3 summarizes the depths and the elevations of the bedrock surface as encountered at the testhole locations from the current and previous investigations.

Table 3: Summary of Bedrock Surface Depths and Elevations

Drillhole / Borehole	Drillhole / Borehole Location	Existing Ground Surface Elevation (m)	Testhole Inclination ¹ (°)	Depth to Bedrock Surface ² (m)	Bedrock Surface Elevation ³ (m)
17-B01D	Sidewalk along Booth Street at east abutment	66.4	88	1.5	64.8
17-B04D		66.4	Vertical	1.7	64.7
17-B08D		66.5	84	1.7	64.9
17-B12D		66.6	79	1.7	65.0
17-B13D	Sidewalk along Booth Street at west abutment	66.6	77	1.8	64.9
17-B16D		66.5	77	1.8	64.8
17-B20D		66.4	78	1.9	64.6
17-B24D		66.3	69	1.6	64.9
17-121	Booth Street Southwest of west abutment	66.6	Vertical	0.9	65.7

Drillhole / Borehole	Drillhole / Borehole Location	Existing Ground Surface Elevation (m)	Testhole Inclination ¹ (°)	Depth to Bedrock Surface ² (m)	Bedrock Surface Elevation ³ (m)
17-122	Booth Street Southeast of east abutment	66.7	Vertical	1.0	65.7
17-123	Booth Street Northwest of west abutment	66.3	Vertical	1.2	65.1
17-124	Booth Street Northeast of east abutment	66.4	Vertical	0.9	65.5
18-1201	Highway 417 Embankment Northwest of west abutment	68.4	Vertical	3.9	64.5
18-1202	Highway 417 Embankment Southwest of west abutment	69.5	Vertical	3.8	65.7
18-1203	Highway 417 Embankment Northeast of east abutment	68.7	Vertical	3.7	65.0
18-1204	Highway 417 Embankment Southeast of east abutment	70.5	Vertical	5.3	65.2
1	West abutment	66.5	Vertical	1.1	65.4
2	West abutment	66.2	Vertical	1.0	65.2
3	East abutment	66.7	Vertical	0.9	65.8
4	East abutment	66.3	Vertical	0.8	65.5
5	West abutment	66.4	Vertical	0.8	65.6
6	East abutment	66.9	Vertical	1.0	65.9
7	East abutment	66.8	Vertical	0.7	66.1

Notes: ¹ Testhole inclination is measured counter clockwise from the vertical

² Depth indicated is measured along the drill path

³ Top of bedrock surface elevation shown is measured vertically from the ground surface

The bedrock encountered was slightly weathered to fresh and thinly to medium bedded. Thin shale interbeds were also present in the bedrock core. Rock Quality Designation (RQD) values measured on recovered bedrock core samples typically ranged from about 0 to 100 percent, but more generally ranged from about 53 to 100 percent indicating fair to excellent quality rock.

Results of unconfined compressive strength (UCS) testing carried out on four bedrock core samples are presented on Figure B7 provided in Appendix B. The samples tested had UCS values ranging from 36 to 74 MPa, indicating a medium strong to strong bedrock.

4.8 Groundwater Conditions

Monitoring wells were installed in Boreholes 17-121, 17-124, and 18-1207 to allow for measurement of the groundwater levels across the site.

Table 4 summarizes the depths and the elevations of the groundwater levels measured in the monitoring wells installed at the site.

Table 4: Summary of Groundwater Conditions

Borehole	Borehole Location	Screened Interval	Depth (m)	Elevation (m)	Date
17-121	West Abutment	Bedrock	2.5	64.1	October 27, 2017
17-124	East Abutment	Bedrock	2.0 2.2	64.4 64.2	April 26, 2017 October 27, 2017
18-1207	East Abutment	Fill and Bedrock	6.9	65.7	December 6, 2018

It is expected that the groundwater levels will be subject to fluctuations both seasonally and as a result of precipitation events.

4.9 Steel Corrosion and Sulphate Attack, Chemical Analysis

One soil sample from Borehole 17-122 was submitted to Eurofins Environmental Testing for chemical analysis related to potential corrosion of exposed buried steel and potential sulphate attack on buried concrete elements (corrosion and sulphate attack). The test results are provided in Appendix D and are summarized in Table 5.



Table 5: Steel Corrosion and Sulphate Attack, Chemical Analysis

Borehole	Sample	Sample Depth (m)	Sample Type	Chloride (%)	Sulphate (%)	Electrical Conductivity (mS/cm)	pH	Resistivity (ohm-cm)
17-122	SS1	0.3 – 0.9	Fill	0.028	<0.01	0.63	8.8	1590

5.0 CLOSURE

This report was prepared by Mr. Kenton Power, P.Eng. It was reviewed by Mr. Bill Cavers, P.Eng., a Senior Geotechnical Engineer and Associate of Golder, and Mr. Matt Kennedy, P.Eng., Senior Geotechnical Engineer. Mr. Fintan Heffernan, P.Eng. a Senior Consultant with Golder and the Designated MTO Foundations Contact for this project, carried out an independent quality control review of this report.

Golder Associates Ltd.



Kenton C. Power, P.Eng, M.A
Geotechnical Engineer



Matt Kennedy, P.Eng
Senior Geotechnical Engineer



Fintan J. Heffernan, P.Eng.
Designated MTO Foundations Contact

KCP/WC/MJK/FJH/hdw

<https://golderassociates.sharepoint.com/sites/18579g/foundations/6-reports/1120-booth/final/1662565-1120-001-reva-final-booth-st-bridge-2019-07-24.docx>

Golder and the G logo are trademarks of Golder Associates Corporation

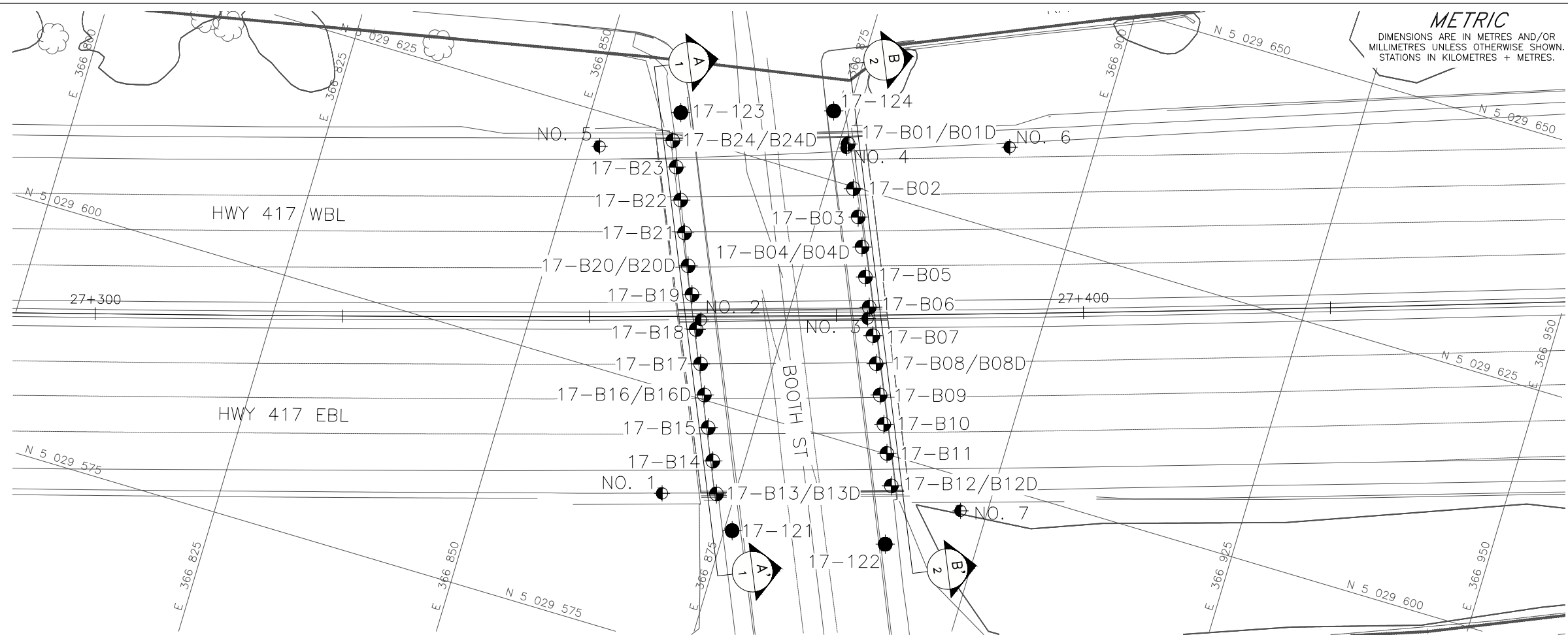

PLAN
SCALE
5 0 5 10 m

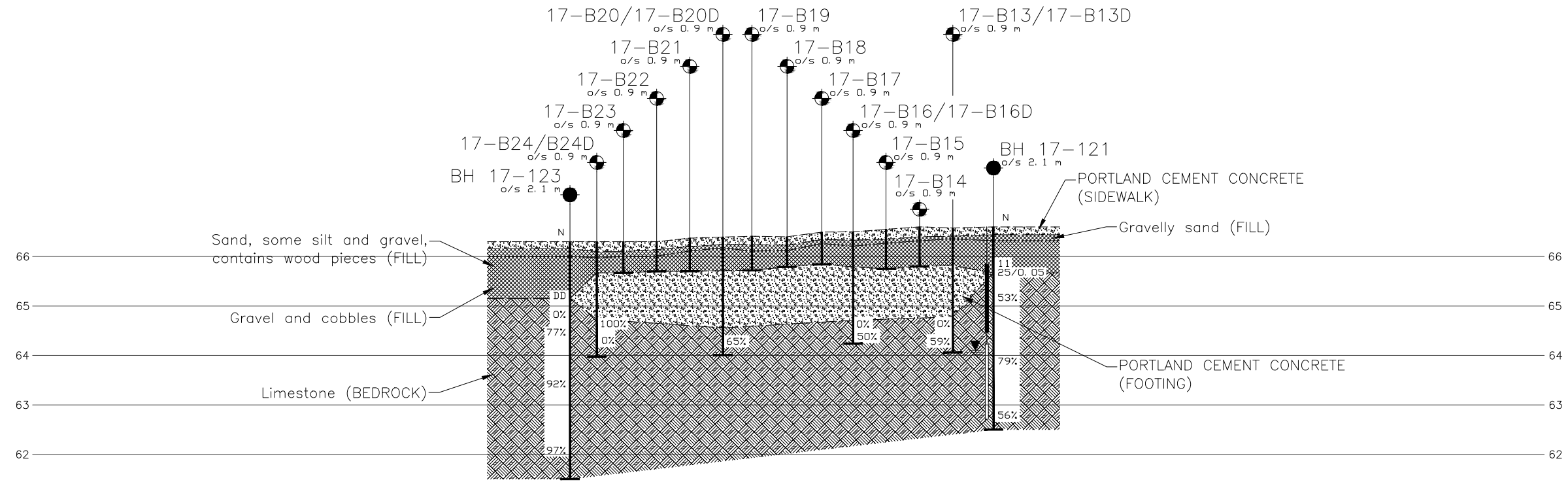

CROSS-SECTION A-A'

SCALE
5 0 5 10 m
1 0 1 2 m

NOTES
This drawing is for subsurface information only. The proposed structure details/works are shown for illustration purposes only and may not be consistent with the final design configuration as shown elsewhere in the Contracts Documents.
The boundaries between soil strata have been established only at borehole locations. Between boreholes the boundaries are assumed from geological evidence.

REFERENCE
Base plans provided in digital format by WSP Canada Limited, drawing file nos. MIDTOWN-XB1.dwg and 3416024-XA1-MEDIAN.dwg, received APR. 19, 2017.

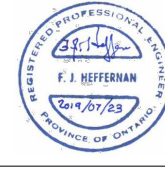
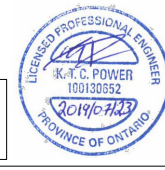

CONT No. GWP No. 4173-15-00
HIGHWAY 417 OVERPASS STRUCTURES AT BOOTH STREET
BOREHOLE LOCATIONS AND SOIL STRATA
LAT. 45.403689 LONG. -75.707079



KEY PLAN
SCALE
500 0 500 1000 m

- LEGEND**
- Borehole - Current Investigation
 - ⊕ Corehole - Current Investigation
 - ⊙ Borehole - Previous Investigation (Geocres No. 31G05-030)
 - Inclined Borehole Orientation
 - ⊥ Seal
 - ⊥ Piezometer
 - N Standard Penetration Test Value
 - 16 Blows/0.3m unless otherwise stated (Std. Pen. Test, 475 j/blow)
 - 100% Rock Quality Designation (RQD)
 - ≡ WL in piezometer, measured on OCTOBER 27, 2017

BOREHOLE CO-ORDINATES NAD 83 (CSRS)/MTM ZONE 9

No.	ELEVATION	NORTHING	EASTING
17-121	66.6	5029588.1	366875.8
17-122	66.7	5029591.2	366891.0
17-123	66.3	5029627.2	366858.8
17-124	66.4	5029631.8	366873.5
17-B01/B01D	66.4	5029629.0	366875.9
17-B02	66.4	5029624.8	366877.7
17-B03	66.4	5029622.2	366879.0
17-B04/B04D	66.4	5029619.4	366880.2
17-B05	66.4	5029616.6	366881.4
17-B06	66.4	5029613.8	366882.6
17-B07	66.5	5029611.1	366883.8
17-B08/B08D	66.5	5029608.5	366884.9
17-B09	66.5	5029605.6	366886.2
17-B10	66.5	5029602.8	366887.4
17-B11	66.6	5029600.1	366888.6
17-B12/B12D	66.6	5029597.1	366889.9
17-B13/B13D	66.6	5029591.2	366873.2
17-B14	66.6	5029594.3	366871.9
17-B15	66.6	5029597.4	366870.5
17-B16/B16D	66.5	5029600.5	366869.2
17-B17	66.5	5029603.4	366867.9
17-B18	66.4	5029606.6	366866.5
17-B19	66.4	5029609.9	366865.1
17-B20/B20D	66.4	5029612.6	366863.9
17-B21	66.4	5029615.6	366862.6
17-B22	66.3	5029618.7	366861.3
17-B23	66.3	5029621.8	366859.9
17-B24/B24D	66.3	5029624.3	366858.8
NO. 1	66.4	5029589.7	366867.9
NO. 2	66.2	5029607.6	366866.6
NO. 3	66.7	5029612.6	366862.8
NO. 4	66.3	5029628.5	366873.8
NO. 5	66.4	5029621.5	366851.8
NO. 6	66.9	5029633.3	366891.6
NO. 7	66.8	5029596.6	366897.3

NO.	DATE	BY	REVISION

Geocres No. 31G5-308

HWY. 417	PROJECT NO. 1655214-1120	DIST. EASTERN
SUBM'D. KP	CHKD. KP	DATE: 25/07/2019
DRAWN: JM	CHKD. FJH	APPD. FJH
		SITE: 3-57.1 & 3-57.2
		DWG. 1

PLOT DATE: 2019-07-25 10:15
 FILENAME: N:\Active\Spatial\LM\MTD\ Hwy417\Rehab\Working\99_PROJ\1655214_MTD\Hwy417\BoreholeLocations\120_BoothSt\1655214-1120-000.dwg

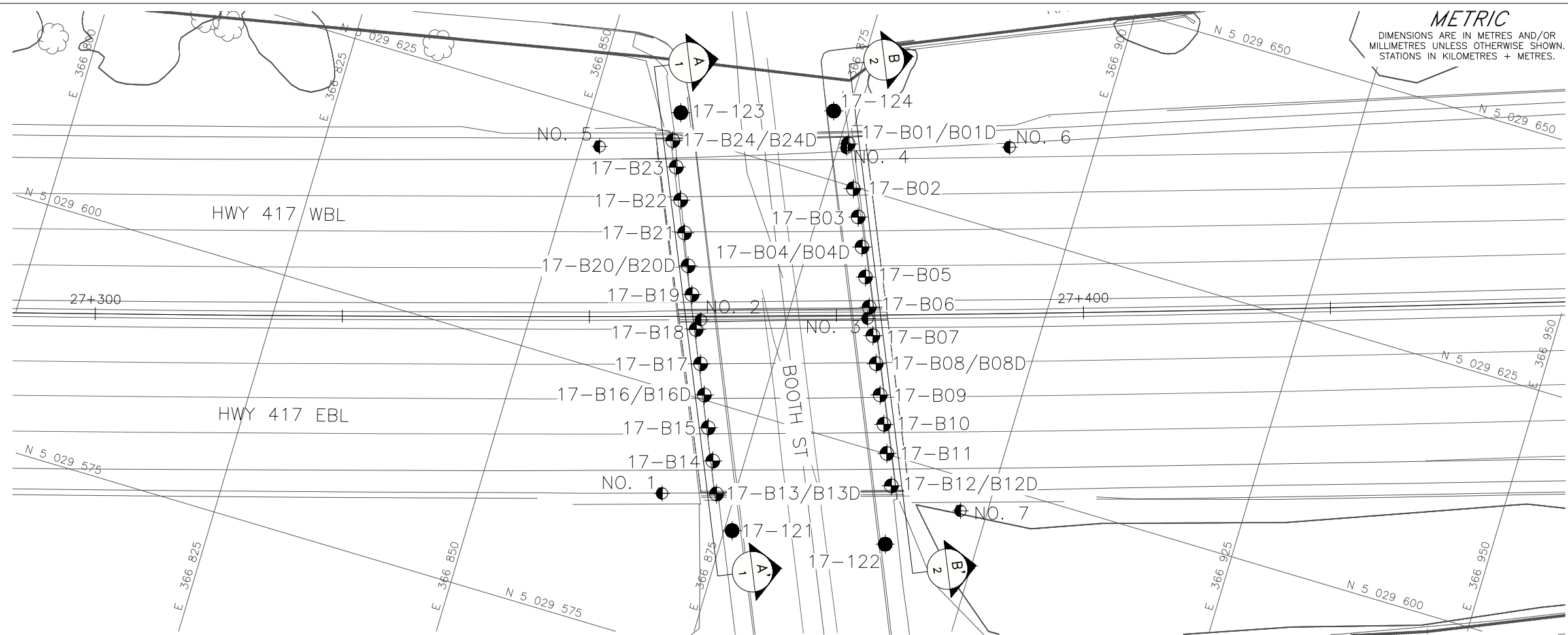

CONT No. GWP No. 4173-15-00

HIGHWAY 417 OVERPASS STRUCTURES AT BOOTH STREET

BOREHOLE LOCATIONS AND SOIL STRATA

LAT. 45.403689 LONG. -75.707079

SHEET

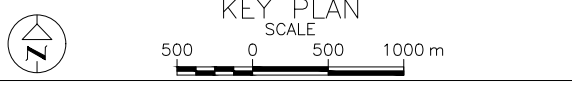

LEGEND

- Borehole - Current Investigation
- ⊕ Corehole - Current Investigation
- ⊙ Borehole - Previous Investigation (Geocres No. 31G05-030)
- Inclined Borehole Orientation
- ⊥ Seal
- ⊥ Piezometer
- N Standard Penetration Test Value
- 16 Blows/0.3m unless otherwise stated (Std. Pen. Test, 475 j/blow)
- 100% Rock Quality Designation (RQD)
- ⊥ WL in piezometer, measured on OCTOBER 27, 2017

BOREHOLE CO-ORDINATES NAD 83 (CSRS)/MTM ZONE 9

No.	ELEVATION	NORTHING	EASTING
17-121	66.6	5029588.1	366875.8
17-122	66.7	5029591.2	366891.0
17-123	66.3	5029627.2	366858.8
17-124	66.4	5029631.8	366873.5
17-B01/B01D	66.4	5029629.0	366875.9
17-B02	66.4	5029624.8	366877.7
17-B03	66.4	5029622.2	366879.0
17-B04/B04D	66.4	5029619.4	366880.2
17-B05	66.4	5029616.6	366881.4
17-B06	66.4	5029613.8	366882.6
17-B07	66.5	5029611.1	366883.8
17-B08/B08D	66.5	5029608.5	366884.9
17-B09	66.5	5029605.6	366886.2
17-B10	66.5	5029602.8	366887.4
17-B11	66.6	5029600.1	366888.6
17-B12/B12D	66.6	5029597.1	366889.9
17-B13/B13D	66.6	5029591.2	366873.2
17-B14	66.6	5029594.3	366871.9
17-B15	66.6	5029597.4	366870.5
17-B16/B16D	66.5	5029600.5	366869.2
17-B17	66.5	5029603.4	366867.9
17-B18	66.4	5029606.6	366866.5
17-B19	66.4	5029609.9	366865.1
17-B20/B20D	66.4	5029612.6	366863.9
17-B21	66.4	5029615.6	366862.6
17-B22	66.3	5029618.7	366861.3
17-B23	66.3	5029621.8	366859.9
17-B24/B24D	66.3	5029624.3	366858.8
NO. 1	66.4	5029589.7	366867.9
NO. 2	66.2	5029607.6	366866.6
NO. 3	66.7	5029612.6	366862.8
NO. 4	66.3	5029628.5	366873.8
NO. 5	66.4	5029621.5	366851.8
NO. 6	66.9	5029633.3	366891.6
NO. 7	66.8	5029596.6	366897.3

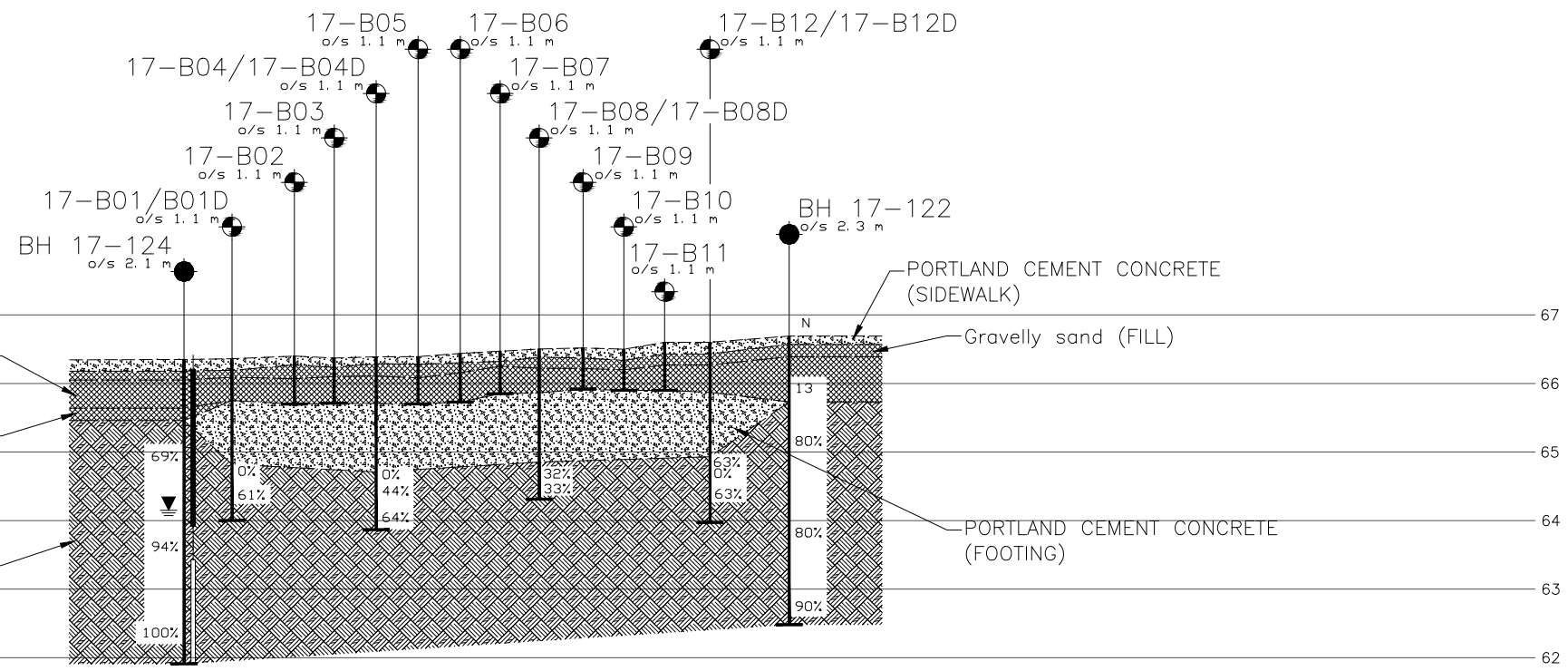

CROSS-SECTION B-B'

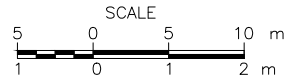

NOTES

This drawing is for subsurface information only. The proposed structure details/works are shown for illustration purposes only and may not be consistent with the final design configuration as shown elsewhere in the Contracts Documents.

The boundaries between soil strata have been established only at borehole locations. Between boreholes the boundaries are assumed from geological evidence.

REFERENCE

Base plans provided in digital format by WSP Canada Limited, drawing file nos. MIDTOWN-XB1.dwg and 3416024-XA1-MEDIAN.dwg, received APR. 19, 2017.



NO.	DATE	BY	REVISION

Geocres No. 31G5-308

HWY. 417	PROJECT NO. 1655214-1120	DIST. EASTERN
SUBM'D. KP	CHKD. KP	DATE: 25/07/2019
DRAWN: JM	CHKD. FJH	APPD. FJH
		SITE: 3-57.1 & 3-57.2
		DWG. 2

PLOT DATE: 16/05/2019
 FILENAME: N:\Active\Spatial\LM\MTD\ Hwy417\Rehab\Replacement\1655214-1120-000.dwg

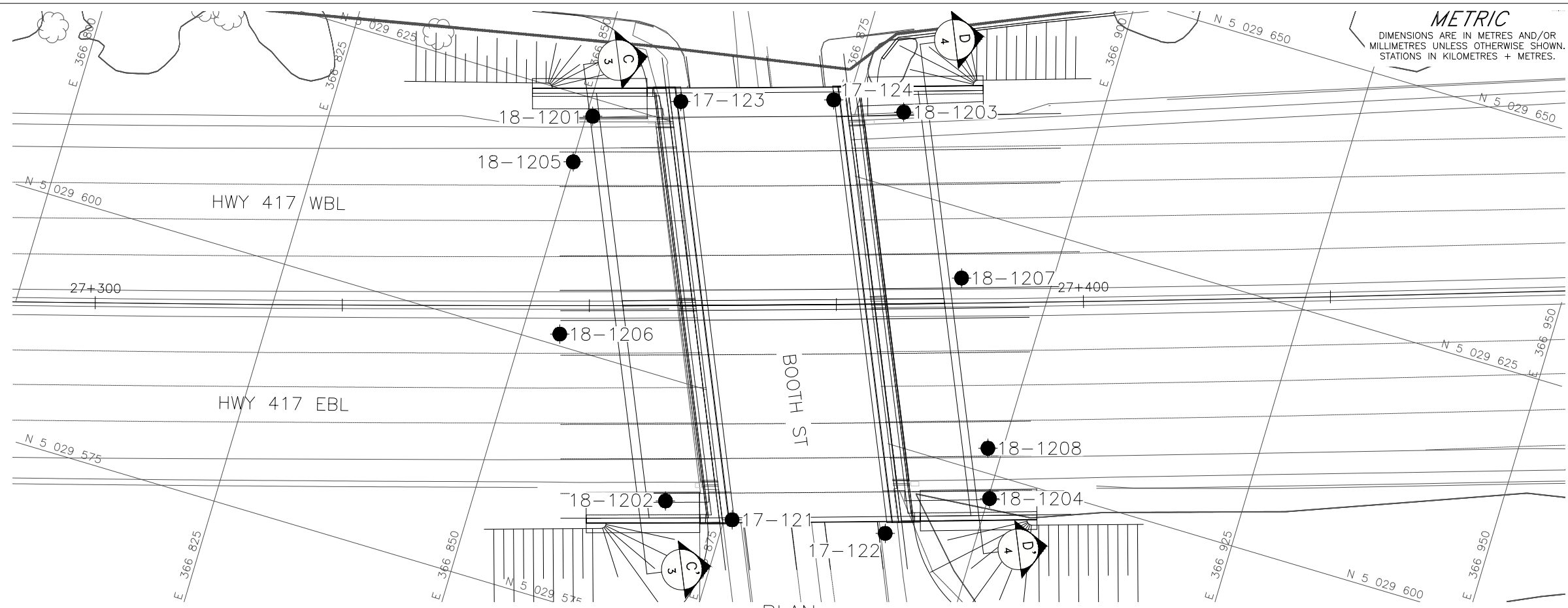

PLAN
SCALE
5 0 5 10 m

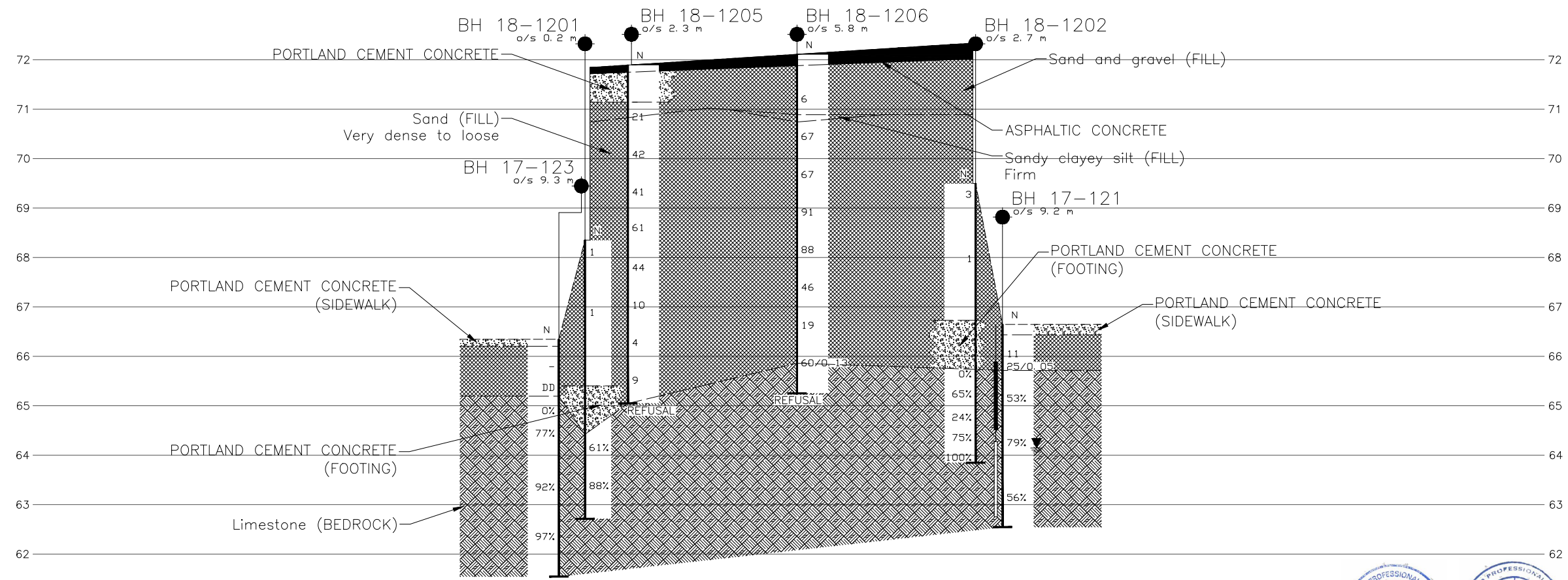

CROSS-SECTION C-C'
SCALE
5 0 5 10 m
1 0 1 2 m

REFERENCE
Base plans provided in digital format by WSP Canada Limited, drawing file no. S3416024-306-001GA.dwg, received MAY 07, 2019.

METRIC
DIMENSIONS ARE IN METRES AND/OR MILLIMETRES UNLESS OTHERWISE SHOWN. STATIONS IN KILOMETRES + METRES.

CONT No.
GWP No. 4173-15-00

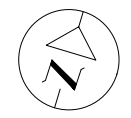

**HIGHWAY 417 OVERPASS
STRUCTURES AT BOOTH STREET**
BOREHOLE LOCATIONS AND SOIL STRATA
LAT. 45.403689 LONG. -75.707079

SHEET



KEY PLAN
SCALE
500 0 500 1000 m

LEGEND

- Borehole - Current Investigation
- ⊥ Seal
- ⊥ Piezometer
- N Standard Penetration Test Value
- 16 Blows/0.3m unless otherwise stated (Std. Pen. Test, 475 j/blow)
- 100% Rock Quality Designation (RQD)
- ⊥ WL in piezometer, measured on OCTOBER 27, 2017

BOREHOLE CO-ORDINATES NAD 83 (CSRS)/MTM ZONE 9

No.	ELEVATION	NORTHING	EASTING
17-121	66.6	5029588.1	366875.8
17-122	67.0	5029591.2	366891.0
17-123	66.3	5029627.2	366858.8
17-124	66.4	5029631.8	366873.5
18-1201	68.4	5029623.2	366850.6
18-1202	69.5	5029588.0	366868.8
18-1203	68.7	5029632.6	366880.7
18-1204	70.5	5029597.6	366900.1
18-1205	71.9	5029618.3	366850.1
18-1206	72.1	5029601.2	366853.7
18-1207	72.6	5029618.2	366891.1
18-1208	72.9	5029602.4	366898.5
18-1209	65.3	5029514.3	366806.2
18-1210	66.0	5029529.9	366838.3
18-1211	66.8	5029545.2	366884.1
18-1212	67.2	5029556.0	366916.4
18-1213	67.8	5029572.0	366933.6

NOTES

This drawing is for subsurface information only. The proposed structure details/works are shown for illustration purposes only and may not be consistent with the final design configuration as shown elsewhere in the Contracts Documents.
The boundaries between soil strata have been established only at borehole locations. Between boreholes the boundaries are assumed from geological evidence.

NO.	DATE	BY	REVISION

Geocres No. 31G5-308		PROJECT NO. 1655214-1120		DIST. EASTERN	
HWY. 417	CHKD. KP	DATE: 25/07/2019	SITE: 3-57.1 & 3-57.2		
SUBM'D. KP	CHKD. FJH	APPD. FJH	DWG. 3		

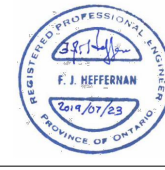

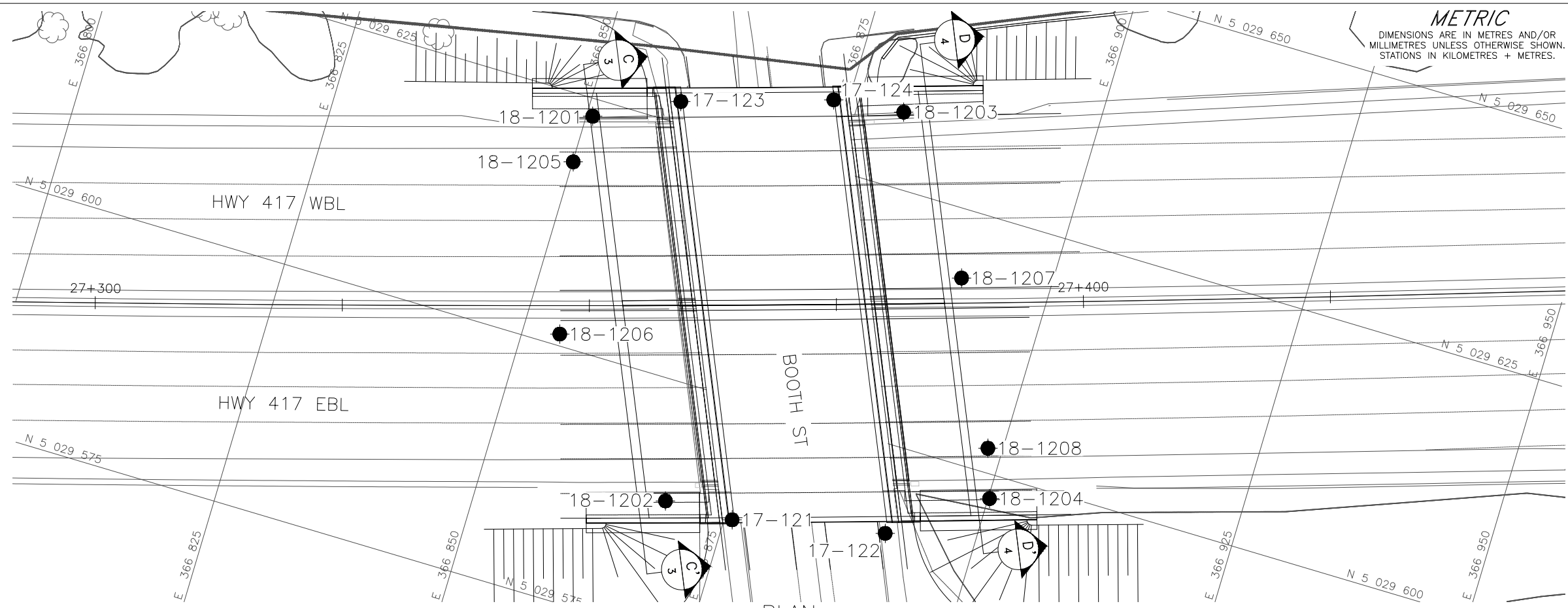

METRIC
DIMENSIONS ARE IN METRES AND/OR MILLIMETRES UNLESS OTHERWISE SHOWN. STATIONS IN KILOMETRES + METRES.

CONT No. GWP No. 4173-15-00

HIGHWAY 417 OVERPASS STRUCTURES AT BOOTH STREET
BOREHOLE LOCATIONS AND SOIL STRATA
LAT. 45.403689 LONG. -75.707079

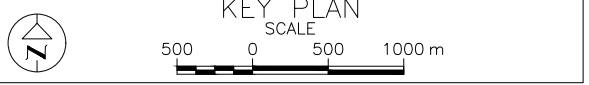
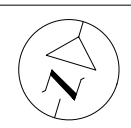

LEGEND

- Borehole - Current Investigation
- ⊥ Seal
- ⊏ Piezometer
- N Standard Penetration Test Value
- 16 Blows/0.3m unless otherwise stated (Std. Pen. Test, 475 j/blow)
- 100% Rock Quality Designation (RQD)
- ≡ WL in piezometer, measured on OCTOBER 27, 2017 and DECEMBER 6, 2018

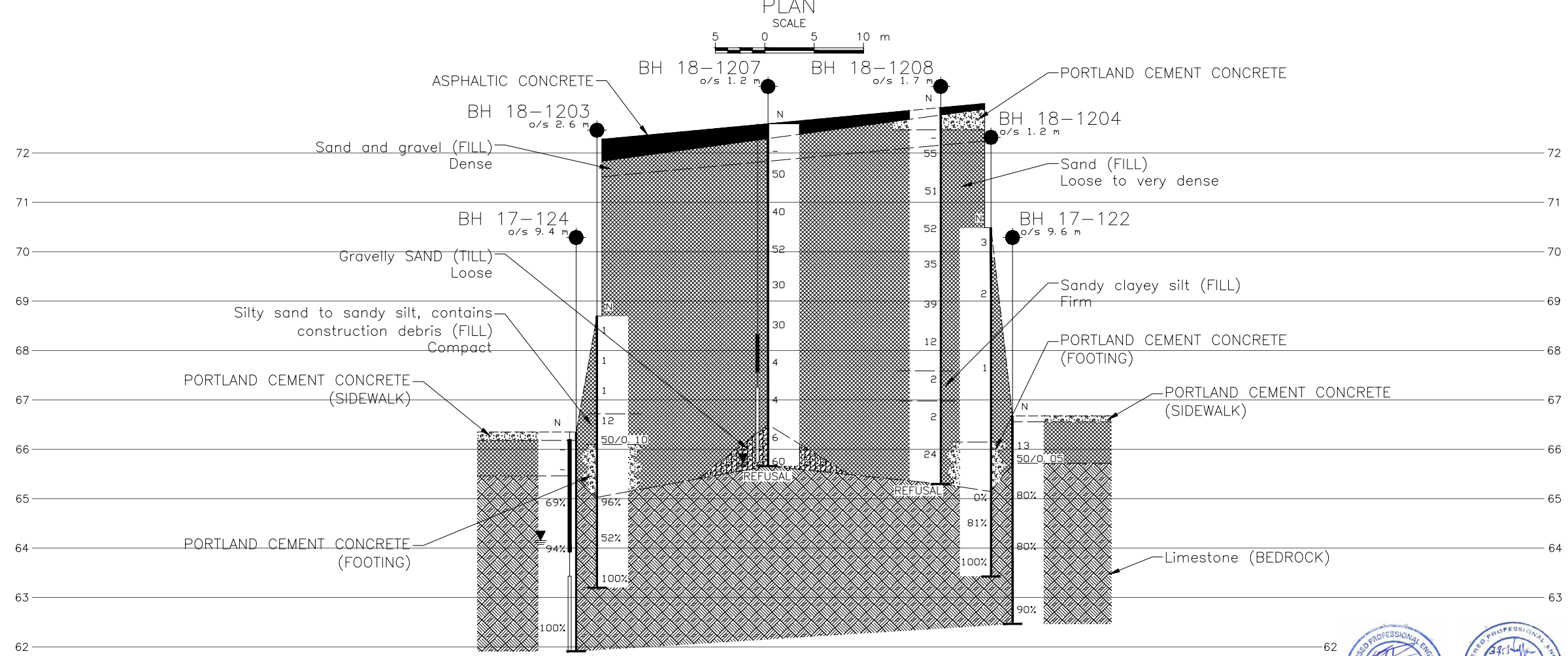

BOREHOLE CO-ORDINATES NAD 83 (CSRS)/MTM ZONE 9

No.	ELEVATION	NORTHING	EASTING
17-121	66.6	5029588.1	366875.8
17-122	67.0	5029591.2	366891.0
17-123	66.3	5029627.2	366858.8
17-124	66.4	5029631.8	366873.5
18-1201	68.4	5029623.2	366850.6
18-1202	69.5	5029588.0	366868.8
18-1203	68.7	5029632.6	366880.7
18-1204	70.5	5029597.6	366900.1
18-1205	71.9	5029618.3	366850.1
18-1206	72.1	5029601.2	366853.7
18-1207	72.6	5029618.2	366891.1
18-1208	72.9	5029602.4	366898.5
18-1209	65.3	5029514.3	366806.2
18-1210	66.0	5029529.9	366838.3
18-1211	66.8	5029545.2	366884.1
18-1212	67.2	5029556.0	366916.4
18-1213	67.8	5029572.0	366933.6

NOTES

This drawing is for subsurface information only. The proposed structure details/works are shown for illustration purposes only and may not be consistent with the final design configuration as shown elsewhere in the Contracts Documents.

The boundaries between soil strata have been established only at borehole locations. Between boreholes the boundaries are assumed from geological evidence.

REFERENCE
Base plans provided in digital format by WSP Canada Limited, drawing file no. S3416024-306-001GA.dwg, received MAY 07, 2019.

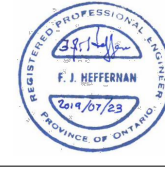
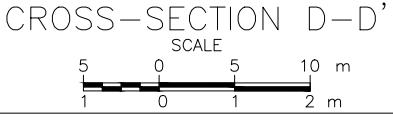

NO.	DATE	BY	REVISION

Geocres No. 31G5-308

HWY. 417	PROJECT NO. 1655214-1120	DIST. EASTERN
SUBM'D. KP	CHKD. KP	DATE: 25/07/2019
DRAWN: JM	CHKD. FJH	APPD. FJH
		SITE: 3-57.1 & 3-57.2
		DWG. 4

PLOT DATE: 16_05_2019
 FILENAME: N:\Active\Spatial\LM\MTD\ Hwy417\Rehab\Working\99_PROJ\1655214_LTD_Hwy417\Rehab\Placement\99_PROJ\Phase1120_BoothSt\1655214-1120-001.dwg

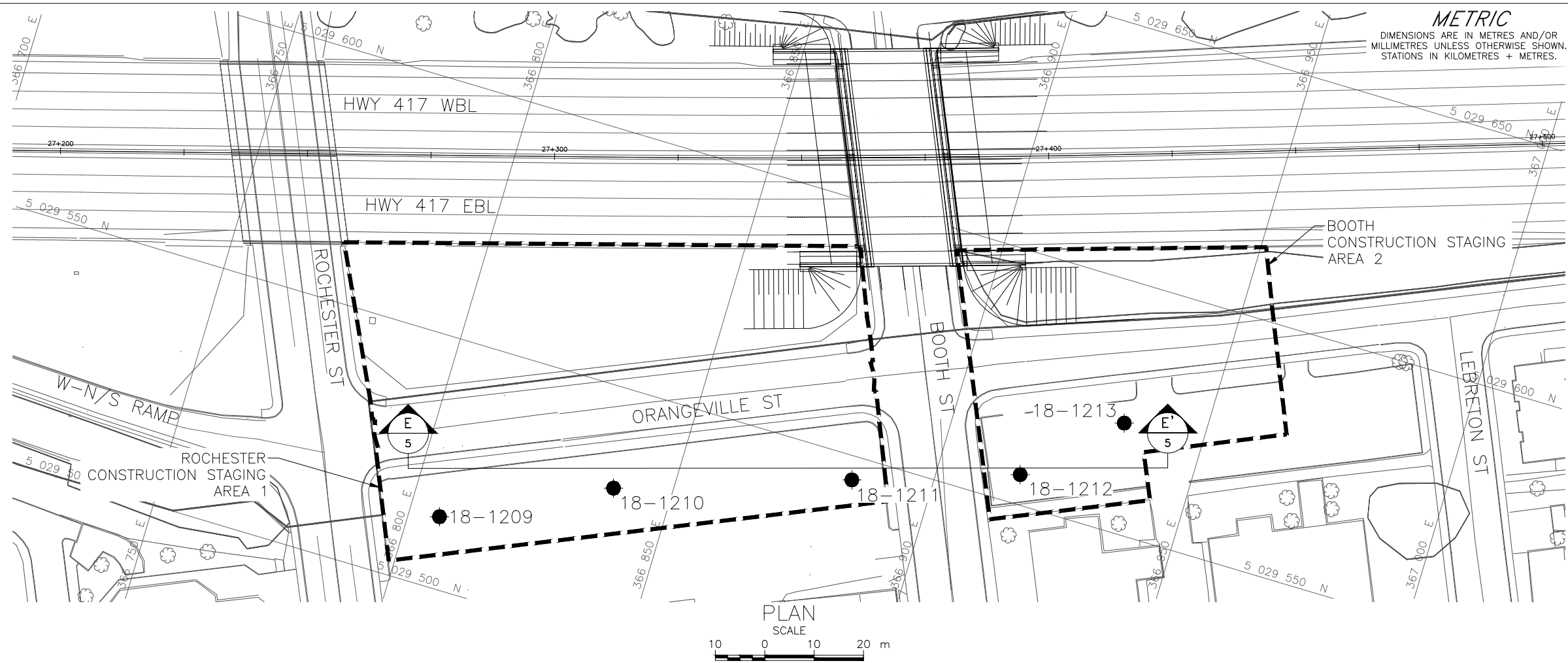

METRIC
DIMENSIONS ARE IN METRES AND/OR MILLIMETRES UNLESS OTHERWISE SHOWN. STATIONS IN KILOMETRES + METRES.

CONT No. GWP No. 4173-15-00



HIGHWAY 417 OVERPASS STRUCTURES AT BOOTH STREET
STAGING AREAS
BOREHOLE LOCATIONS AND SOIL STRATA
LAT. 45.403170 LONG. -75.706753

SHEET



KEY PLAN
SCALE
500 0 500 1000 m

LEGEND

- Borehole - Current Investigation
- N Standard Penetration Test Value
- 16 Blows/0.3m unless otherwise stated (Std. Pen. Test, 475 j/blow)

BOREHOLE CO-ORDINATES NAD 83 (CSRS)/MTM ZONE 9

No.	ELEVATION	NORTHING	EASTING
18-1209	65.3	5029514.3	366806.2
18-1210	66.0	5029529.9	366838.3
18-1211	66.8	5029545.2	366884.1
18-1212	67.2	5029556.0	366916.4
18-1213	67.8	5029572.0	366933.6

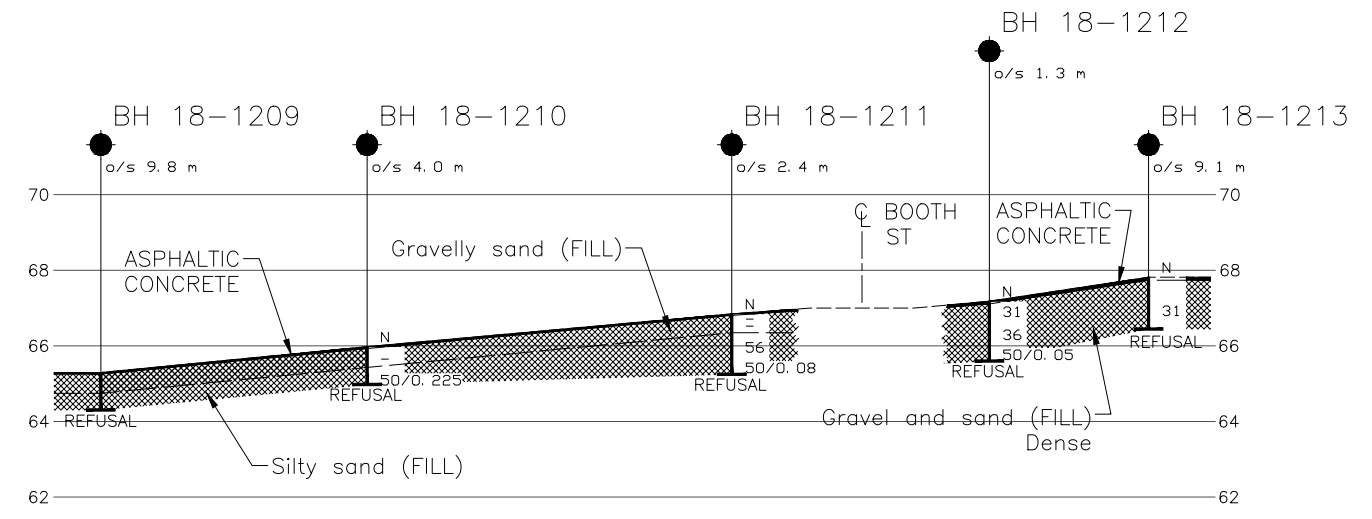

CROSS-SECTION E-E'

SCALE
10 0 10 20 m
2 0 2 4 m

REFERENCE



Base plans provided in digital format by WSP Canada Limited, drawing file no. 3416024-XSTAGING AREA.dwg, received MARCH 22, 2019.

NOTES
This drawing is for subsurface information only. The proposed structure details/works are shown for illustration purposes only and may not be consistent with the final design configuration as shown elsewhere in the Contracts Documents.
The boundaries between soil strata have been established only at borehole locations. Between boreholes the boundaries are assumed from geological evidence.

NO.	DATE	BY	REVISION

Geocres No. 31G5-308

HWY. 417	PROJECT NO. 1655214-1120	DIST. EASTERN
SUBM'D. KP	CHKD. KP	DATE: 25/07/2019
DRAWN: JM	CHKD. FJH	APPD. FJH
		SITE: 3-57.1 & 3-57.2
		DWG. 5

APPENDIX A

Lists of Abbreviations and Symbols
Lithological and Geotechnical Rock Description Terminology
Record of Coreholes/Drillholes 17-B01 to 17-B24
Record of Boreholes 17-121 to 17-124
Record of Boreholes 18-1201 to 18-1213
Bedrock Core Photographs, Figures A1 to A31
Table A1 - Concrete Core Condition Assessment

LIST OF SYMBOLS

Unless otherwise stated, the symbols employed in the report are as follows:

I.	GENERAL	(a)	Index Properties (continued)
π	3.1416	w	water content
$\ln x$,	natural logarithm of x	w_l or LL	liquid limit
\log_{10}	x or log x, logarithm of x to base 10	w_p or PL	plastic limit
g	acceleration due to gravity	I_p or PI	plasticity index = $(w_l - w_p)$
t	time	w_s	shrinkage limit
FoS	factor of safety	I_L	liquidity index = $(w - w_p) / I_p$
		IC	consistency index = $(w_l - w) / I_p$
		e_{max}	void ratio in loosest state
		e_{min}	void ratio in densest state
		I_D	density index = $(e_{max} - e) / (e_{max} - e_{min})$ (formerly relative density)
II.	STRESS AND STRAIN	(b)	Hydraulic Properties
γ	shear strain	h	hydraulic head or potential
Δ	change in, e.g. in stress: $\Delta \sigma$	q	rate of flow
ε	linear strain	v	velocity of flow
ε_v	volumetric strain	i	hydraulic gradient
η	coefficient of viscosity	k	hydraulic conductivity (coefficient of permeability)
ν	Poisson's ratio	j	seepage force per unit volume
σ	total stress	(c)	Consolidation (one-dimensional)
σ'	effective stress ($\sigma' = \sigma - u$)	C	compression index (normally consolidated range)
σ'_{vo}	initial effective overburden stress	C_r	recompression index (over-consolidated range)
$\sigma_1, \sigma_2, \sigma_3$	principal stress (major, minor)	C_s	swelling index
σ_{oct}	mean stress or octahedral stress = $(\sigma_1 + \sigma_2 + \sigma_3) / 3$	C_α	secondary compression index
τ	shear stress	m_v	coefficient of volume change
u	porewater pressure	C_v	coefficient of consolidation (vertical direction)
E	modulus of deformation	C_h	coefficient of consolidation (horizontal direction)
G	shear modulus of deformation	T_v	time factor (vertical direction)
K	bulk modulus of compressibility	U	degree of consolidation
III.	SOIL PROPERTIES	σ'_p	pre-consolidation stress
(a)	Index Properties	OCR	over-consolidation ratio = σ'_p / σ'_{vo}
$\rho(\gamma)$	bulk density (bulk unit weight)*	(d)	Shear Strength
$\rho_d(\gamma_d)$	dry density (dry unit weight)	τ_p, τ_r	peak and residual shear strength
$\rho_w(\gamma_w)$	density (unit weight) of water	ϕ'	effective angle of internal friction
$\rho_s(\gamma_s)$	density (unit weight) of solid particles	δ	angle of interface friction
γ'	unit weight of submerged soil ($\gamma' = \gamma - \gamma_w$)	μ	coefficient of friction = $\tan \delta$
D_R	relative density (specific gravity) of solid particles ($D_R = \rho_s / \rho_w$) (formerly G_s)	c'	effective cohesion
e	void ratio	c_u, s_u	undrained shear strength ($\phi = 0$ analysis)
n	porosity	p	mean total stress $(\sigma_1 + \sigma_3) / 2$
S	degree of saturation	p'	mean effective stress $(\sigma'_1 + \sigma'_3) / 2$
		q	$(\sigma_1 - \sigma_3) / 2$ or $(\sigma'_1 - \sigma'_3) / 2$
		q_u	compressive strength $(\sigma_1 - \sigma_3)$
		S_t	sensitivity

* Density symbol is ρ . Unit weight symbol is γ where $\gamma = \rho g$ (i.e. mass density multiplied by acceleration due to gravity)

Notes: 1
2

$\tau = c' + \sigma' \tan \phi'$
shear strength = (compressive strength)/2

LIST OF ABBREVIATIONS

The abbreviations commonly employed on Records of Boreholes, on figures and in the text of the report are as follows:

I. SAMPLE TYPE

AS	Auger sample
BS	Block sample
CS	Chunk sample
DS	Denison type sample
FS	Foil sample
RC	Rock core
SC	Soil core
SS	Split-spoon
ST	Slotted tube
TO	Thin-walled, open
TP	Thin-walled, piston
WS	Wash sample

II. PENETRATION RESISTANCE

Standard Penetration Resistance (SPT), N:

The number of blows by a 63.5 kg. (140 lb.) hammer dropped 760 mm (30 in.) required to drive a 50 mm (2 in.) drive open sampler for a distance of 300 mm (12 in.)

Dynamic Cone Penetration Resistance; N_d :

The number of blows by a 63.5 kg (140 lb.) hammer dropped 760 mm (30 in.) to drive uncased a 50 mm (2 in.) diameter, 60° cone attached to "A" size drill rods for a distance of 300 mm (12 in.).

PH: Sampler advanced by hydraulic pressure

PM: Sampler advanced by manual pressure

WH: Sampler advanced by static weight of hammer

WR: Sampler advanced by weight of sampler and rod

Piezo-Cone Penetration Test (CPT)

A electronic cone penetrometer with a 60° conical tip and a project end area of 10 cm² pushed through ground at a penetration rate of 2 cm/s. Measurements of tip resistance (Q_t), porewater pressure (PWP) and friction along a sleeve are recorded electronically at 25 mm penetration intervals.

III. SOIL DESCRIPTION

(a) Non-Cohesive (Cohesionless) Soils

Compactness Condition	N Blows/300 mm or Blows/ft
Very loose	0 to 4
Loose	4 to 10
Compact	10 to 30
Dense	30 to 50
Very dense	over 50

(b) Cohesive Soils

Consistency	kPa	psf
Very soft		
Soft	0 to 12	0 to 250
Firm	12 to 25	250 to 500
Stiff	25 to 50	500 to 1,000
Very stiff	100 to 200	1,000 to 2,000
Hard	over 200	over 4,000

IV. SOIL TESTS

w	water content
w _p	plastic limit
w _l	liquid limit
C	consolidation (oedometer) test
CHEM	chemical analysis (refer to text)
CID	consolidated isotropically drained triaxial test ¹
CIU	consolidated isotropically undrained triaxial test with porewater pressure measurement ¹
D _R	relative density (specific gravity, G _s)
DS	direct shear test
M	sieve analysis for particle size
MH	combined sieve and hydrometer (H) analysis
MPC	Modified Proctor compaction test
SPC	Standard Proctor compaction test
OC	organic content test
SO ₄	concentration of water-soluble sulphates
UC	unconfined compression test
UU	unconsolidated undrained triaxial test
V	field vane (LV-laboratory vane test)
γ	unit weight

Note: 1 Tests which are anisotropically consolidated prior to shear are shown as CAD, CAU.

V. MINOR SOIL CONSTITUENTS

Per cent by Weight	Modifier	Example
0 to 10	Trace	Trace sand
10 to 20	Some	Some sand
20 to 35	(ey) or (y)	Sandy
over 35	And	Sand and Gravel

LITHOLOGICAL AND GEOTECHNICAL ROCK DESCRIPTION TERMINOLOGY

WEATHERINGS STATE

Fresh: no visible sign of weathering

Faintly weathered: weathering limited to the surface of major discontinuities.

Slightly weathered: penetrative weathering developed on open discontinuity surfaces but only slight weathering of rock material.

Moderately weathered: weathering extends throughout the rock mass but the rock material is not friable.

Highly weathered: weathering extends throughout rock mass and the rock material is partly friable.

Completely weathered: rock is wholly decomposed and in a friable condition but the rock and structure are preserved.

BEDDING THICKNESS

<u>Description</u>	<u>Bedding Plane Spacing</u>
Very thickly bedded	Greater than 2 m
Thickly bedded	0.6 m to 2 m
Medium bedded	0.2 m to 0.6 m
Thinly bedded	60 mm to 0.2 m
Very thinly bedded	20 mm to 60 mm
Laminated	6 mm to 20 mm
Thinly laminated	Less than 6 mm

JOINT OR FOLIATION SPACING

<u>Description</u>	<u>Spacing</u>
Very wide	Greater than 3 m
Wide	1 m to 3 m
Moderately close	0.3 m to 1 m
Close	50 mm to 300 mm
Very close	Less than 50 mm

GRAIN SIZE

<u>Term</u>	<u>Size*</u>
Very Coarse Grained	Greater than 60 mm
Coarse Grained	2 mm to 60 mm
Medium Grained	60 microns to 2 mm
Fine Grained	2 microns to 60 microns
Very Fine Grained	Less than 2 microns

Note: * Grains greater than 60 microns diameter are visible to the naked eye.

CORE CONDITION

Total Core Recovery (TCR)

The percentage of solid drill core recovered regardless of quality or length, measured relative to the length of the total core run.

Solid Core Recovery (SCR)

The percentage of solid drill core, regardless of length, recovered at full diameter, measured relative to the length of the total core run.

Rock Quality Designation (RQD)

The percentage of solid drill core, greater than 100 mm length, as measured along the centerline axis of the core, relative to the length of the total core run. RQD varies from 0% for completely broken core to 100% for core in solid segments.

DISCONTINUITY DATA

Fracture Index

A count of the number of discontinuities (physical separations) in the rock core, including both naturally occurring fractures and mechanically induced breaks caused by drilling.

Dip with Respect to Core Axis

The angle of the discontinuity relative to the axis (length) of the core. In a vertical borehole a discontinuity with a 90° angle is horizontal.

Description and Notes

An abbreviation description of the discontinuities, whether naturally occurring separations such as fractures, bedding planes and foliation planes or mechanically induced features caused by drilling such as ground or shattered core and mechanically separated bedding or foliation surfaces. Additional information concerning the nature of fracture surfaces and infillings are also noted.

Abbreviations

JN Joint	PL Planar
FLT Fault	CU Curved
SH Shear	UN Undulating
VN Vein	IR Irregular
FR Fracture	K Slickensided
SY Stylolite	PO Polished
BD Bedding	SM Smooth
FO Foliation	SR Slightly Rough
CO Contact	RO Rough
AXJ Axial Joint	VR Very Rough
KV Karstic Void	
MB Mechanical Break	



PROJECT <u>1655214-1120</u>	RECORD OF COREHOLE No 17-B01	SHEET 1 OF 1	METRIC
G.W.P. <u>4173-15-00</u>	LOCATION <u>N 5029629.0; E 366875.9 NAD 83 MTM ZONE 9 (LAT. 45.403855; LONG. -75.707036)</u>	ORIGINATED BY <u>DWM</u>	
DIST <u>Eastern</u> HWY <u>417</u>	BOREHOLE TYPE <u>Portable Drill/Hydro-excavation</u>	COMPILED BY <u>ZS</u>	
DATUM <u>Geodetic</u>	DATE <u>March 20, 2017</u>	CHECKED BY <u>KCP</u>	

SOIL PROFILE		SAMPLES			GROUND WATER CONDITIONS	ELEVATION SCALE	DYNAMIC CONE PENETRATION RESISTANCE PLOT					PLASTIC LIMIT W _p	NATURAL MOISTURE CONTENT W	LIQUID LIMIT W _L	UNIT WEIGHT γ kN/m ³	REMARKS & GRAIN SIZE DISTRIBUTION (%) GR SA SI CL
ELEV DEPTH	DESCRIPTION	STRAT PLOT	NUMBER	TYPE			"N" VALUES	20	40	60	80					
66.4	GROUND SURFACE															
0.0	PORTLAND CEMENT CONCRETE (SIDEWALK)															
66.2																
66.1	(SP) Gravelly sand (FILL) Grey															
0.3	(SP) Gravelly sand, trace silt, contains cobbles (FILL) Brown					66										
65.8	END OF COREHOLE															
0.6	NOTES: 1. Corehole continued on Record of Drillhole 17-B01D.															

GTA-MTO 001 N:\ACTIVE\SPATIAL_IMMTO\HWY417REHAB&WIDENING\02_DATA\GINT\1655214.GPJ GAL-GTA.GDT 6/12/19 JM

+³, ×³: Numbers refer to Sensitivity ○ 3% STRAIN AT FAILURE

PROJECT <u>1655214-1120</u>	RECORD OF COREHOLE No 17-B02	SHEET 1 OF 1	METRIC
G.W.P. <u>4173-15-00</u>	LOCATION <u>N 5029624.8; E 366877.7 NAD 83 MTM ZONE 9 (LAT. 45.403817; LONG. -75.707014)</u>	ORIGINATED BY <u>DWM</u>	
DIST <u>Eastern</u> HWY <u>417</u>	BOREHOLE TYPE <u>Portable Drill/Hydro-excavation</u>	COMPILED BY <u>ZS</u>	
DATUM <u>Geodetic</u>	DATE <u>March 20, 2017</u>	CHECKED BY <u>KCP</u>	

SOIL PROFILE		SAMPLES			GROUND WATER CONDITIONS	ELEVATION SCALE	DYNAMIC CONE PENETRATION RESISTANCE PLOT					PLASTIC LIMIT W _p	NATURAL MOISTURE CONTENT W	LIQUID LIMIT W _L	UNIT WEIGHT γ kN/m ³	REMARKS & GRAIN SIZE DISTRIBUTION (%) GR SA SI CL
ELEV DEPTH	DESCRIPTION	STRAT PLOT	NUMBER	TYPE			"N" VALUES	20	40	60	80					
66.4	GROUND SURFACE															
0.0	PORTLAND CEMENT CONCRETE (SIDEWALK)															
66.3	(SP) Gravelly sand (FILL) Grey-brown															
0.1																
65.7						66										
0.7	END OF COREHOLE															

GTA-MTO 001 N:\ACTIVE\SPATIAL_IMMTO\HWY417REHAB&WIDENING02_DATA\GINT\1655214.GPJ GAL-GTA.GDT 6/12/19 JM

PROJECT <u>1655214-1120</u>	RECORD OF COREHOLE No 17-B04	SHEET 1 OF 1	METRIC
G.W.P. <u>4173-15-00</u>	LOCATION <u>N 5029619.4; E 366880.2 NAD 83 MTM ZONE 9 (LAT. 45.403768; LONG. -75.706982)</u>	ORIGINATED BY <u>DWM</u>	
DIST <u>Eastern</u> HWY <u>417</u>	BOREHOLE TYPE <u>Portable Drill/Hydro-excavation</u>	COMPILED BY <u>ZS</u>	
DATUM <u>Geodetic</u>	DATE <u>March 20, 2017</u>	CHECKED BY <u>KCP</u>	

SOIL PROFILE		SAMPLES			GROUND WATER CONDITIONS	ELEVATION SCALE	DYNAMIC CONE PENETRATION RESISTANCE PLOT					PLASTIC LIMIT W _p	NATURAL MOISTURE CONTENT W	LIQUID LIMIT W _L	UNIT WEIGHT γ	REMARKS & GRAIN SIZE DISTRIBUTION (%)		
ELEV DEPTH	DESCRIPTION	STRAT PLOT	NUMBER	TYPE			"N" VALUES	20	40	60	80						100	WATER CONTENT (%)
66.4	GROUND SURFACE																	
0.0	PORTLAND CEMENT CONCRETE (SIDEWALK)																	
66.3	(SP) Gravelly sand (FILL) Grey																	
0.1																		
66.1																		
0.3	(SP) Sand, trace silt and gravel, contains cobbles (FILL) Brown																	
66.7																		
0.7	END OF COREHOLE																	
	NOTES: 1. Corehole continued on Record of Drillhole 17-B04D.																	

GTA-MTO 001 N:\ACTIVE\SPATIAL_IMMTO\HWY417REHAB&WIDENING02_DATA\GINT\1655214.GPJ GAL-GTA.GDT 6/12/19 JM

+³, ×³: Numbers refer to Sensitivity ○ 3% STRAIN AT FAILURE

PROJECT: 1655214-1120

RECORD OF DRILLHOLE: 17-B04D

SHEET 1 OF 1

LOCATION: N 5029619.4 ;E 366880.2

DRILLING DATE: March 27, 2017

DATUM: Geodetic

INCLINATION: -90° AZIMUTH: ---

DRILL RIG: Portable Drill

DRILLING CONTRACTOR: CCC

DEPTH SCALE METRES	DRILLING RECORD	DESCRIPTION	SYMBOLIC LOG	ELEV. DEPTH (m)	RUN No.	NOTE: For abbreviations, symbols and descriptions refer to LITHOLOGICAL AND GEOTECHNICAL ROCK DESCRIPTION TERMINOLOGY											FEATURES								
						RECOVERY		R.Q.D. %	FRACT. INDEX PER	DISCONTINUITY DATA			HYDRAULIC CONDUCTIVITY K, cm/sec			WEATHERING INDEX									
						TOTAL CORE %	SOLID CORE %			TYPE AND SURFACE DESCRIPTION	Jr	Ja	10 ^u	10 ^v	10 ^w	W1		W2	W3	W4	W5	W6			
		TOP OF FOOTING		65.71																					
1	Portable Drill BC Core	PORTLAND CEMENT CONCRETE (FOOTING)		0.68	C1																				
2		Limestone (BEDROCK), with black shale partings Slightly weathered Thinly to medium bedded Grey Fine grained Non-porous Medium strong to strong		64.71 1.68	C1 C2 C3																				
3		END OF DRILLHOLE		63.87 2.52																					
4																									
5																									

GTA-RCK 031 N:\ACTIVE\SPATIAL_IMMTO\HWY417\REHAB&WIDENING\02_DATA\GINT\1655214.GPJ GAL-MISS_GDT_6/12/19_JM

DEPTH SCALE

1 : 25



LOGGED: DWM

CHECKED: KCP



PROJECT <u>1655214-1120</u>	RECORD OF COREHOLE No 17-B05	SHEET 1 OF 1	METRIC
G.W.P. <u>4173-15-00</u>	LOCATION <u>N 5029616.6; E 366881.4 NAD 83 MTM ZONE 9 (LAT. 45.403743; LONG. -75.706967)</u>	ORIGINATED BY <u>DWM</u>	
DIST <u>Eastern</u> HWY <u>417</u>	BOREHOLE TYPE <u>Portable Drill/Hydro-excavation</u>	COMPILED BY <u>ZS</u>	
DATUM <u>Geodetic</u>	DATE <u>March 20, 2017</u>	CHECKED BY <u>KCP</u>	

SOIL PROFILE		SAMPLES			GROUND WATER CONDITIONS	ELEVATION SCALE	DYNAMIC CONE PENETRATION RESISTANCE PLOT					PLASTIC LIMIT W _p	NATURAL MOISTURE CONTENT W	LIQUID LIMIT W _L	UNIT WEIGHT γ	REMARKS & GRAIN SIZE DISTRIBUTION (%)
ELEV DEPTH	DESCRIPTION	STRAT PLOT	NUMBER	TYPE			"N" VALUES	20	40	60	80					
66.4	GROUND SURFACE															
0.0	PORTLAND CEMENT CONCRETE (SIDEWALK)															
66.3	(SP) Gravelly sand (FILL) Grey															
0.1																
66.1	(SM) Silty sand, some gravel, contains cobbles (FILL) Brown		1	GRAB	-											17 62 (21)
0.3																
65.7	END OF COREHOLE															
0.7																

GTA-MTO 001 N:\ACTIVE\SPATIAL_IMMTO\HWY417REHAB&WIDENING\02_DATA\GINT\1655214.GPJ GAL-GTA.GDT 6/12/19 JM

+³, ×³: Numbers refer to Sensitivity ○ 3% STRAIN AT FAILURE

PROJECT <u>1655214-1120</u>	RECORD OF COREHOLE No 17-B06	SHEET 1 OF 1	METRIC
G.W.P. <u>4173-15-00</u>	LOCATION <u>N 5029613.8; E 366882.6 NAD 83 MTM ZONE 9 (LAT. 45.403717; LONG. -75.706952)</u>	ORIGINATED BY <u>DWM</u>	
DIST <u>Eastern</u> HWY <u>417</u>	BOREHOLE TYPE <u>Portable Drill/Hydro-excavation</u>	COMPILED BY <u>ZS</u>	
DATUM <u>Geodetic</u>	DATE <u>March 20, 2017</u>	CHECKED BY <u>KCP</u>	

SOIL PROFILE		SAMPLES			GROUND WATER CONDITIONS	ELEVATION SCALE	DYNAMIC CONE PENETRATION RESISTANCE PLOT					PLASTIC LIMIT W _p	NATURAL MOISTURE CONTENT W	LIQUID LIMIT W _L	UNIT WEIGHT γ	REMARKS & GRAIN SIZE DISTRIBUTION (%)		
ELEV DEPTH	DESCRIPTION	STRAT PLOT	NUMBER	TYPE			"N" VALUES	20	40	60	80						100	25
66.4	GROUND SURFACE																	
0.0	PORTLAND CEMENT CONCRETE (SIDEWALK)																	
66.3	(SP) Gravelly sand (FILL) Grey																	
0.1																		
66.1																		
0.3	(SP) Sand, trace silt, some gravel, contains cobbles (FILL) Brown																	
65.7						66												
0.7	END OF COREHOLE																	

GTA-MTO 001 N:\ACTIVE\SPATIAL_IMMTO\HWY417REHAB&WIDENING\02_DATA\GINT\1655214.GPJ GAL-GTA.GDT 6/12/19 JM

PROJECT <u>1655214-1120</u>	RECORD OF COREHOLE No 17-B07	SHEET 1 OF 1	METRIC
G.W.P. <u>4173-15-00</u>	LOCATION <u>N 5029611.1; E 366883.8 NAD 83 MTM ZONE 9 (LAT. 45.403693; LONG. -75.706937)</u>	ORIGINATED BY <u>DWM</u>	
DIST <u>Eastern</u> HWY <u>417</u>	BOREHOLE TYPE <u>Portable Drill/Hydro-excavation</u>	COMPILED BY <u>ZS</u>	
DATUM <u>Geodetic</u>	DATE <u>March 20, 2017</u>	CHECKED BY <u>KCP</u>	

SOIL PROFILE		SAMPLES			GROUND WATER CONDITIONS	ELEVATION SCALE	DYNAMIC CONE PENETRATION RESISTANCE PLOT					PLASTIC LIMIT NATURAL MOISTURE CONTENT LIQUID LIMIT			UNIT WEIGHT γ kN/m ³	REMARKS & GRAIN SIZE DISTRIBUTION (%)	
ELEV DEPTH	DESCRIPTION	STRAT PLOT	NUMBER	TYPE			"N" VALUES	20	40	60	80	100	W _p	W			W _L
66.5	GROUND SURFACE																
0.0	PORTLAND CEMENT CONCRETE (SIDEWALK)																
66.4																	
0.2	(SP) Gravelly sand (FILL) Grey (SP-SM) Sand, some silt and gravel (FILL) Brown Moist		1	GRAB	-												
65.9						66											
0.6	END OF COREHOLE																

GTA-MTO 001 N:\ACTIVE\SPATIAL_IMMTO\HWY417REHAB&WIDENING02_DATA\GINT\1655214.GPJ GAL-GTA.GDT 6/12/19 JM

+³, ×³: Numbers refer to Sensitivity ○ 3% STRAIN AT FAILURE

PROJECT <u>1655214-1120</u>	RECORD OF COREHOLE No 17-B08	SHEET 1 OF 1	METRIC
G.W.P. <u>4173-15-00</u>	LOCATION <u>N 5029608.5; E 366884.9 NAD 83 MTM ZONE 9 (LAT. 45.403670; LONG. -75.706923)</u>	ORIGINATED BY <u>DWM</u>	
DIST <u>Eastern</u> HWY <u>417</u>	BOREHOLE TYPE <u>Portable Drill/Hydro-excavation</u>	COMPILED BY <u>ZS</u>	
DATUM <u>Geodetic</u>	DATE <u>March 20, 2017</u>	CHECKED BY <u>KCP</u>	

SOIL PROFILE		SAMPLES			GROUND WATER CONDITIONS	ELEVATION SCALE	DYNAMIC CONE PENETRATION RESISTANCE PLOT					PLASTIC NATURAL LIQUID LIMIT			UNIT WEIGHT	REMARKS & GRAIN SIZE DISTRIBUTION (%)
ELEV DEPTH	DESCRIPTION	STRAT PLOT	NUMBER	TYPE			"N" VALUES	20	40	60	80	100	W _p	W		
66.5	GROUND SURFACE															
0.0	PORTLAND CEMENT CONCRETE (SIDEWALK)															
66.4																
0.1	(SP) Gravelly sand, contains cobbles (FILL)		1	GRAB	-											
66.2	Grey															
0.3	(SP-SM) Sand, some silt and gravel (FILL)															
65.9	Brown															
0.6	END OF COREHOLE															
	NOTES: 1. Corehole continued on Record of Drillhole 17-B08D.															

GTA-MTO 001 N:\ACTIVE\SPATIAL_IMMTO\HWY417REHAB&WIDENING02_DATA\GINT\1655214.GPJ GAL-GTA.GDT 6/12/19 JM

+³, ×³: Numbers refer to Sensitivity ○ 3% STRAIN AT FAILURE

PROJECT: 1655214-1120
 LOCATION: N 5029608.5 ; E 366884.9
 INCLINATION: -84° AZIMUTH:

RECORD OF DRILLHOLE: 17-B08D

SHEET 1 OF 1
 DATUM: Geodetic

DRILLING DATE: March 23, 2017
 DRILL RIG: Portable Drill
 DRILLING CONTRACTOR: CCC

DEPTH SCALE METRES	DRILLING RECORD	DESCRIPTION	SYMBOLIC LOG	ELEV. DEPTH (m)	RUN No.	NOTE: For abbreviations, symbols and descriptions refer to LITHOLOGICAL AND GEOTECHNICAL ROCK DESCRIPTION TERMINOLOGY										FEATURES									
						RECOVERY		R.Q.D. %	FRACT. INDEX PER	DISCONTINUITY DATA			HYDRAULIC CONDUCTIVITY K, cm/sec				WEATHERING INDEX								
						TOTAL CORE %	SOLID CORE %			TYPE AND SURFACE DESCRIPTION	Jr	Ja	10 ^u	10 ^v	10 ^w		W1	W2	W3	W4	W5	W6			
		TOP OF FOOTING		65.87																					
1	Portable Drill BQ Core	PORTLAND CEMENT CONCRETE (FOOTING)		0.64	C1	0																			
2		Limestone (BEDROCK), with black shale partings Slightly weathered Thinly to medium bedded Grey Fine grained Non-porous Medium strong to strong		64.86 1.65	C2	0																			
		END OF DRILLHOLE		64.32 2.19	C3	0																			
3																									
4																									
5																									

GTA-RCK 031 N:\ACTIVE\SPATIAL_IMMTO\HWY417\REHAB&WIDENING\02_DATA\GINT\1655214.GPJ GAL-MISS.GDT 6/12/19 JM

DEPTH SCALE
1 : 25



LOGGED: DWM
CHECKED: KCP

PROJECT <u>1655214-1120</u>	RECORD OF COREHOLE No 17-B09	SHEET 1 OF 1	METRIC
G.W.P. <u>4173-15-00</u>	LOCATION <u>N 5029605.6; E 366886.2 NAD 83 MTM ZONE 9 (LAT. 45.403643; LONG. -75.706907)</u>	ORIGINATED BY <u>DWM</u>	
DIST <u>Eastern</u> HWY <u>417</u>	BOREHOLE TYPE <u>Portable Drill/Hydro-excavation</u>	COMPILED BY <u>ZS</u>	
DATUM <u>Geodetic</u>	DATE <u>March 20, 2017</u>	CHECKED BY <u>KCP</u>	

SOIL PROFILE		SAMPLES			GROUND WATER CONDITIONS	ELEVATION SCALE	DYNAMIC CONE PENETRATION RESISTANCE PLOT					PLASTIC LIMIT W _p	NATURAL MOISTURE CONTENT W	LIQUID LIMIT W _L	UNIT WEIGHT γ kN/m ³	REMARKS & GRAIN SIZE DISTRIBUTION (%) GR SA SI CL
ELEV DEPTH	DESCRIPTION	STRAT PLOT	NUMBER	TYPE			"N" VALUES	20	40	60	80					
66.5	GROUND SURFACE															
0.0	PORTLAND CEMENT CONCRETE (SIDEWALK)															
66.4	(SP) Gravelly sand (FILL) Grey															
0.1																
66.2																
0.3	(SP-SM) Sand, some silt and gravel (FILL) Brown															
65.9																
0.6	END OF COREHOLE															
						66										

GTA-MTO 001 N:\ACTIVE\SPATIAL_IMMTO\HWY417REHAB&WIDENING02_DATA\GINT\1655214.GPJ GAL-GTA.GDT 6/12/19 JM

+³, ×³: Numbers refer to Sensitivity ○ 3% STRAIN AT FAILURE

PROJECT <u>1655214-1120</u>	RECORD OF COREHOLE No 17-B10	SHEET 1 OF 1	METRIC
G.W.P. <u>4173-15-00</u>	LOCATION <u>N 5029602.8; E 366887.4 NAD 83 MTM ZONE 9 (LAT. 45.403619; LONG. -75.706892)</u>	ORIGINATED BY <u>DWM</u>	
DIST <u>Eastern</u> HWY <u>417</u>	BOREHOLE TYPE <u>Portable Drill/Hydro-excavation</u>	COMPILED BY <u>ZS</u>	
DATUM <u>Geodetic</u>	DATE <u>March 20, 2017</u>	CHECKED BY <u>KCP</u>	

SOIL PROFILE		SAMPLES			GROUND WATER CONDITIONS	ELEVATION SCALE	DYNAMIC CONE PENETRATION RESISTANCE PLOT					PLASTIC LIMIT W _p	NATURAL MOISTURE CONTENT W	LIQUID LIMIT W _L	UNIT WEIGHT γ	REMARKS & GRAIN SIZE DISTRIBUTION (%)
ELEV DEPTH	DESCRIPTION	STRAT PLOT	NUMBER	TYPE			"N" VALUES	20	40	60	80					
66.5	GROUND SURFACE															
0.0	PORTLAND CEMENT CONCRETE (SIDEWALK)															
66.3	(SP) Gravelly sand (FILL) Grey															
0.2 66.2	(SP-SM) Sand, some silt and gravel (FILL) Brown Moist		1	GRAB	-											
0.3																
65.9																
0.6	END OF COREHOLE															

GTA-MTO 001 N:\ACTIVE\SPATIAL_IMMTO\HWY417REHAB&WIDENING02_DATA\GINT\1655214.GPJ GAL-GTA.GDT 6/12/19 JM

+³, ×³: Numbers refer to Sensitivity ○ 3% STRAIN AT FAILURE

PROJECT <u>1655214-1120</u>	RECORD OF COREHOLE No 17-B11	SHEET 1 OF 1	METRIC
G.W.P. <u>4173-15-00</u>	LOCATION <u>N 5029600.1; E 366888.6 NAD 83 MTM ZONE 9 (LAT. 45.403594; LONG. -75.706877)</u>	ORIGINATED BY <u>DWM</u>	
DIST <u>Eastern</u> HWY <u>417</u>	BOREHOLE TYPE <u>Portable Drill/Hydro-excavation</u>	COMPILED BY <u>ZS</u>	
DATUM <u>Geodetic</u>	DATE <u>March 20, 2017</u>	CHECKED BY <u>KCP</u>	

SOIL PROFILE		SAMPLES			GROUND WATER CONDITIONS	ELEVATION SCALE	DYNAMIC CONE PENETRATION RESISTANCE PLOT					PLASTIC LIMIT NATURAL MOISTURE CONTENT LIQUID LIMIT			UNIT WEIGHT γ kN/m ³	REMARKS & GRAIN SIZE DISTRIBUTION (%) GR SA SI CL
ELEV DEPTH	DESCRIPTION	STRAT PLOT	NUMBER	TYPE			"N" VALUES	20	40	60	80	100	W _p	W		
66.6	GROUND SURFACE															
0.0	PORTLAND CEMENT CONCRETE (SIDEWALK)															
66.4	(SP) Gravelly sand (FILL) Grey		1	GRAB	-											
66.3	(SP-SM) Sand some silt and gravel, contains bedrock fragments (FILL) Brown Moist		2	GRAB	-											
65.9	END OF COREHOLE					66										
0.7																

GTA-MTO 001 N:\ACTIVE\SPATIAL_IMMTO\HWY417REHAB&WIDENING02_DATA\GINT\1655214.GPJ GAL-GTA.GDT 6/12/19 JM

+³, ×³: Numbers refer to Sensitivity ○ 3% STRAIN AT FAILURE

PROJECT <u>1655214-1120</u>	RECORD OF COREHOLE No 17-B12	SHEET 1 OF 1	METRIC
G.W.P. <u>4173-15-00</u>	LOCATION <u>N 5029597.1; E 366889.9 NAD 83 MTM ZONE 9 (LAT. 45.403566; LONG. -75.706860)</u>	ORIGINATED BY <u>DWM</u>	
DIST <u>Eastern</u> HWY <u>417</u>	BOREHOLE TYPE <u>Portable Drill/Hydro-excavation</u>	COMPILED BY <u>ZS</u>	
DATUM <u>Geodetic</u>	DATE <u>March 20, 2017</u>	CHECKED BY <u>KCP</u>	

SOIL PROFILE		SAMPLES			GROUND WATER CONDITIONS	ELEVATION SCALE	DYNAMIC CONE PENETRATION RESISTANCE PLOT					PLASTIC NATURAL LIQUID LIMIT			UNIT WEIGHT	REMARKS & GRAIN SIZE DISTRIBUTION (%)
ELEV DEPTH	DESCRIPTION	STRAT PLOT	NUMBER	TYPE			"N" VALUES	20	40	60	80	100	W _p	W		
66.6	GROUND SURFACE															
0.0	PORTLAND CEMENT CONCRETE (SIDEWALK)															
66.4	(SM/GM) Sand and gravel, some silt (FILL)		1	GRAB	-										35 54 (11)	
66.3	Grey															
0.3	(SP-SM) Sand, some silt and gravel (FILL)		2	GRAB	-											
65.9	Brown Moist															
0.7	END OF COREHOLE															
	NOTES: 1. Corehole continued on Record of Drillhole 17-B12D.															

GTA-MTO 001 N:\ACTIVE\SPATIAL_IMMTO\HWY417REHAB&WIDENING\02_DATA\GINT\1655214.GPJ GAL-GTA.GDT 6/12/19 JM

+³, ×³: Numbers refer to Sensitivity ○ 3% STRAIN AT FAILURE

PROJECT <u>1655214-1120</u>	RECORD OF COREHOLE No 17-B13	SHEET 1 OF 1	METRIC
G.W.P. <u>4173-15-00</u>	LOCATION <u>N 5029591.2; E 366873.2 NAD 83 MTM ZONE 9 (LAT. 45.403516; LONG. -75.707075)</u>	ORIGINATED BY <u>DWM</u>	
DIST <u>Eastern</u> HWY <u>417</u>	BOREHOLE TYPE <u>Portable Drill/Hydro-excavation</u>	COMPILED BY <u>ZS</u>	
DATUM <u>Geodetic</u>	DATE <u>March 28, 2017</u>	CHECKED BY <u>KCP</u>	

SOIL PROFILE		SAMPLES			GROUND WATER CONDITIONS	ELEVATION SCALE	DYNAMIC CONE PENETRATION RESISTANCE PLOT					PLASTIC NATURAL LIQUID LIMIT			UNIT WEIGHT	REMARKS & GRAIN SIZE DISTRIBUTION (%)
ELEV DEPTH	DESCRIPTION	STRAT PLOT	NUMBER	TYPE			"N" VALUES	20	40	60	80	100	W _p	W		
66.6	GROUND SURFACE															
0.0	PORTLAND CEMENT CONCRETE (SIDEWALK)															
66.4			1	GRAB	-											
0.2	(SP) Gravelly sand (FILL) Grey															
	(SM) Sand, some silt (FILL) Brown Moist		2	GRAB	-											3 83 (14)
65.8																
0.8	END OF COREHOLE															
	NOTES: 1. Corehole continued on Record of Drillhole 17-B13D.															

GTA-MTO 001 N:\ACTIVE\SPATIAL_IMMTO\HWY417REHAB&WIDENING02_DATA\GINT\1655214.GPJ GAL-GTA.GDT 6/12/19 JM

+³, ×³: Numbers refer to Sensitivity ○ 3% STRAIN AT FAILURE

PROJECT: 1655214-1120
 LOCATION: N 5029591.2 ;E 366873.2
 INCLINATION: -77° AZIMUTH:

RECORD OF DRILLHOLE: 17-B13D

SHEET 1 OF 1
 DATUM: Geodetic

DRILLING DATE: March 30, 2017
 DRILL RIG: Portable Drill
 DRILLING CONTRACTOR: CCC

DEPTH SCALE METRES	DRILLING RECORD	DESCRIPTION	SYMBOLIC LOG	ELEV. DEPTH (m)	RUN No.	NOTE: For abbreviations, symbols and descriptions refer to LITHOLOGICAL AND GEOTECHNICAL ROCK DESCRIPTION TERMINOLOGY										FEATURES							
						RECOVERY		R.Q.D. %	FRACT. INDEX PER	DISCONTINUITY DATA		HYDRAULIC CONDUCTIVITY K, cm/sec		WEATHERING INDEX									
						TOTAL CORE %	SOLID CORE %			TYPE AND SURFACE DESCRIPTION	Jr	Ja	W1	W2	W3		W4	W5	W6				
		TOP OF FOOTING		65.87																			
1	Portable Drill BQ Core	PORTLAND CEMENT CONCRETE (FOOTING)		0.75	C1	0-100																	
				64.86	C2	0-100																	
2		Limestone (BEDROCK), with shale partings Slightly weathered Thinly bedded Grey Fine grained Non-porous Medium strong to strong		1.79	C2	0																	
				64.16	C3	0																	
		END OF DRILLHOLE		2.51																			
3																							
4																							
5																							

GTA-RCK 031 N:\ACTIVE\SPATIAL_IMMTO\HWY417\REHAB&WIDENING\02_DATA\GINT\1655214.GPJ GAL-MISS.GDT 6/12/19 JM

PROJECT <u>1655214-1120</u>	RECORD OF COREHOLE No 17-B14	SHEET 1 OF 1	METRIC
G.W.P. <u>4173-15-00</u>	LOCATION <u>N 5029594.3; E 366871.9 NAD 83 MTM ZONE 9 (LAT. 45.403544; LONG. -75.707091)</u>	ORIGINATED BY <u>DWM</u>	
DIST <u>Eastern</u> HWY <u>417</u>	BOREHOLE TYPE <u>Portable Drill/Hydro-excavation</u>	COMPILED BY <u>ZS</u>	
DATUM <u>Geodetic</u>	DATE <u>March 28, 2017</u>	CHECKED BY <u>KCP</u>	

SOIL PROFILE		SAMPLES			GROUND WATER CONDITIONS	ELEVATION SCALE	DYNAMIC CONE PENETRATION RESISTANCE PLOT					PLASTIC LIMIT W _p	NATURAL MOISTURE CONTENT W	LIQUID LIMIT W _L	UNIT WEIGHT γ kN/m ³	REMARKS & GRAIN SIZE DISTRIBUTION (%) GR SA SI CL
ELEV DEPTH	DESCRIPTION	STRAT PLOT	NUMBER	TYPE			"N" VALUES	SHEAR STRENGTH kPa								
							20	40	60	80	100					
66.6	GROUND SURFACE															
0.0	PORTLAND CEMENT CONCRETE (SIDEWALK)															
66.4	(SP) Gravelly sand (FILL) Grey															
0.3	(SP-SM) Sand, some silt and gravel, contains cobbles (FILL) Brown					66										
65.8	END OF COREHOLE															
0.8																

GTA-MTO 001 N:\ACTIVE\SPATIAL_IMMTO\HWY417REHAB&WIDENING02_DATA\GINT\1655214.GPJ GAL-GTA.GDT 6/12/19 JM

+³, ×³: Numbers refer to Sensitivity ○ 3% STRAIN AT FAILURE

PROJECT <u>1655214-1120</u>	RECORD OF COREHOLE No 17-B15	SHEET 1 OF 1	METRIC
G.W.P. <u>4173-15-00</u>	LOCATION <u>N 5029597.4; E 366870.5 NAD 83 MTM ZONE 9 (LAT. 45.403571; LONG. -75.707109)</u>	ORIGINATED BY <u>DWM</u>	
DIST <u>Eastern</u> HWY <u>417</u>	BOREHOLE TYPE <u>Portable Drill/Hydro-excavation</u>	COMPILED BY <u>ZS</u>	
DATUM <u>Geodetic</u>	DATE <u>March 28, 2017</u>	CHECKED BY <u>KCP</u>	

SOIL PROFILE		SAMPLES			GROUND WATER CONDITIONS	ELEVATION SCALE	DYNAMIC CONE PENETRATION RESISTANCE PLOT					PLASTIC NATURAL LIQUID LIMIT			UNIT WEIGHT	REMARKS & GRAIN SIZE DISTRIBUTION (%)
ELEV DEPTH	DESCRIPTION	STRAT PLOT	NUMBER	TYPE			"N" VALUES	20	40	60	80	100	W _p	W		
66.6	GROUND SURFACE															
0.0	PORTLAND CEMENT CONCRETE (SIDEWALK)															
66.4	(SP) Gravelly sand (FILL) Grey															
0.3	(SP-SM) Sand some silt and gravel, contains cobbles (FILL) Brown		1	GRAB	-											
65.8																
0.8	END OF COREHOLE															

GTA-MTO 001 N:\ACTIVE\SPATIAL_IMMTO\HWY417REHAB&WIDENING02_DATA\GINT\1655214.GPJ GAL-GTA.GDT 6/12/19 JM

PROJECT <u>1655214-1120</u>	RECORD OF COREHOLE No 17-B16	SHEET 1 OF 1	METRIC
G.W.P. <u>4173-15-00</u>	LOCATION <u>N 5029600.5; E 366869.2 NAD 83 MTM ZONE 9 (LAT. 45.403599; LONG. -75.707125)</u>	ORIGINATED BY <u>DWM</u>	
DIST <u>Eastern</u> HWY <u>417</u>	BOREHOLE TYPE <u>Portable Drill/Hydro-excavation</u>	COMPILED BY <u>ZS</u>	
DATUM <u>Geodetic</u>	DATE <u>March 28, 2017</u>	CHECKED BY <u>KCP</u>	

SOIL PROFILE		SAMPLES			GROUND WATER CONDITIONS	ELEVATION SCALE	DYNAMIC CONE PENETRATION RESISTANCE PLOT					PLASTIC NATURAL LIQUID LIMIT MOISTURE LIMIT CONTENT			UNIT WEIGHT γ kN/m ³	REMARKS & GRAIN SIZE DISTRIBUTION (%) GR SA SI CL		
ELEV DEPTH	DESCRIPTION	STRAT PLOT	NUMBER	TYPE			"N" VALUES	20	40	60	80	100	W _p	W			W _L	25
66.5	GROUND SURFACE																	
0.0	PORTLAND CEMENT CONCRETE (SIDEWALK)																	
66.3																		
66.2	(SP) Gravelly sand (FILL) Grey Moist		1	GRAB	-													
0.3	(SP-SM) Sand some silt and gravel (FILL) Brown Moist																	
65.8	END OF COREHOLE																	
0.7	NOTES: 1. Corehole continued on Record of Drillhole 17-B16D.																	

GTA-MTO 001 N:\ACTIVE\SPATIAL_IMMTO\HWY417REHAB&WIDENING02_DATA\GINT\1655214.GPJ GAL-GTA.GDT 6/12/19 JM

PROJECT <u>1655214-1120</u>	RECORD OF COREHOLE No 17-B17	SHEET 1 OF 1	METRIC
G.W.P. <u>4173-15-00</u>	LOCATION <u>N 5029603.4; E 366867.9 NAD 83 MTM ZONE 9 (LAT. 45.403625; LONG. -75.707141)</u>	ORIGINATED BY <u>DWM</u>	
DIST <u>Eastern</u> HWY <u>417</u>	BOREHOLE TYPE <u>Portable Drill/Hydro-excavation</u>	COMPILED BY <u>ZS</u>	
DATUM <u>Geodetic</u>	DATE <u>March 28, 2017</u>	CHECKED BY <u>KCP</u>	

SOIL PROFILE		SAMPLES			GROUND WATER CONDITIONS	ELEVATION SCALE	DYNAMIC CONE PENETRATION RESISTANCE PLOT					PLASTIC NATURAL LIQUID LIMIT MOISTURE LIMIT CONTENT			UNIT WEIGHT γ kN/m ³	REMARKS & GRAIN SIZE DISTRIBUTION (%) GR SA SI CL
ELEV DEPTH	DESCRIPTION	STRAT PLOT	NUMBER	TYPE			"N" VALUES	20	40	60	80	100	W _p	W		
66.5	GROUND SURFACE															
0.0	PORTLAND CEMENT CONCRETE (SIDEWALK)															
66.4	(SP) Gravelly sand (FILL) Grey															
0.2	(SP-SM) Sand, some silt and gravel, contains cobbles (FILL) Brown Moist		1	GRAB	-											
65.8																
0.7	END OF COREHOLE															

GTA-MTO 001 N:\ACTIVE\SPATIAL_IMMTO\HWY417REHAB&WIDENING02_DATA\GINT\1655214.GPJ GAL-GTA.GDT 6/12/19 JM

PROJECT <u>1655214-1120</u>	RECORD OF COREHOLE No 17-B18	SHEET 1 OF 1	METRIC
G.W.P. <u>4173-15-00</u>	LOCATION <u>N 5029606.6; E 366866.5 NAD 83 MTM ZONE 9 (LAT. 45.403654; LONG. -75.707159)</u>	ORIGINATED BY <u>DWM</u>	
DIST <u>Eastern</u> HWY <u>417</u>	BOREHOLE TYPE <u>Portable Drill/Hydro-excavation</u>	COMPILED BY <u>ZS</u>	
DATUM <u>Geodetic</u>	DATE <u>March 28, 2017</u>	CHECKED BY <u>KCP</u>	

SOIL PROFILE		SAMPLES			GROUND WATER CONDITIONS	ELEVATION SCALE	DYNAMIC CONE PENETRATION RESISTANCE PLOT					PLASTIC NATURAL LIQUID LIMIT			UNIT WEIGHT	REMARKS & GRAIN SIZE DISTRIBUTION (%)		
ELEV DEPTH	DESCRIPTION	STRAT PLOT	NUMBER	TYPE			"N" VALUES	20	40	60	80	100	W _p	W			W _L	25
66.4	GROUND SURFACE																	
0.0	PORTLAND CEMENT CONCRETE (SIDEWALK)																	
66.2																		
66.1	(SP) Gravelly sand (FILL) Grey																	
0.3	(SP-SM) Sand, some silt and gravel (FILL) Brown Moist		1	GRAB	-													
65.8																		
0.6	END OF COREHOLE																	

GTA-MTO 001 N:\ACTIVE\SPATIAL_IMMTO\HWY417REHAB&WIDENING02_DATA\GINT\1655214.GPJ GAL-GTA.GDT 6/12/19 JM

+³, ×³: Numbers refer to Sensitivity ○ 3% STRAIN AT FAILURE

PROJECT <u>1655214-1120</u>	RECORD OF COREHOLE No 17-B19	SHEET 1 OF 1	METRIC
G.W.P. <u>4173-15-00</u>	LOCATION <u>N 5029609.9; E 366865.1 NAD 83 MTM ZONE 9 (LAT. 45.403684; LONG. -75.707176)</u>	ORIGINATED BY <u>DWM</u>	
DIST <u>Eastern</u> HWY <u>417</u>	BOREHOLE TYPE <u>Portable Drill/Hydro-excavation</u>	COMPILED BY <u>ZS</u>	
DATUM <u>Geodetic</u>	DATE <u>March 28, 2017</u>	CHECKED BY <u>KCP</u>	

ELEV DEPTH	SOIL PROFILE DESCRIPTION	STRAT PLOT	SAMPLES			GROUND WATER CONDITIONS	ELEVATION SCALE	DYNAMIC CONE PENETRATION RESISTANCE PLOT					PLASTIC LIMIT W _p	NATURAL MOISTURE CONTENT W	LIQUID LIMIT W _L	UNIT WEIGHT γ kN/m ³	REMARKS & GRAIN SIZE DISTRIBUTION (%) GR SA SI CL
			NUMBER	TYPE	"N" VALUES			20	40	60	80	100					
66.4	GROUND SURFACE																
0.0	PORTLAND CEMENT CONCRETE (SIDEWALK)																
66.2																	
66.1	(SM/GM) Sand and gravel, some silt (FILL) Grey Moist		1	GRAB	-												38 50 (12)
0.3	(SP-SM) Sand, some silt, trace gravel (FILL) Brown Moist						66										
65.7																	
0.7	END OF COREHOLE																

GTA-MTO 001 N:\ACTIVE\SPATIAL_IMMTO\HWY417REHAB&WIDENING02_DATA\GINT\1655214.GPJ GAL-GTA.GDT 6/12/19 JM

PROJECT <u>1655214-1120</u>	RECORD OF COREHOLE No 17-B20	SHEET 1 OF 1	METRIC
G.W.P. <u>4173-15-00</u>	LOCATION <u>N 5029612.6; E 366863.9 NAD 83 MTM ZONE 9 (LAT. 45.403708; LONG. -75.707191)</u>	ORIGINATED BY <u>DWM</u>	
DIST <u>Eastern</u> HWY <u>417</u>	BOREHOLE TYPE <u>Portable Drill/Hydro-excavation</u>	COMPILED BY <u>ZS</u>	
DATUM <u>Geodetic</u>	DATE <u>March 28, 2017</u>	CHECKED BY <u>KCP</u>	

SOIL PROFILE		SAMPLES			GROUND WATER CONDITIONS	ELEVATION SCALE	DYNAMIC CONE PENETRATION RESISTANCE PLOT					PLASTIC LIMIT NATURAL MOISTURE CONTENT LIQUID LIMIT			UNIT WEIGHT γ kN/m ³	REMARKS & GRAIN SIZE DISTRIBUTION (%) GR SA SI CL
ELEV DEPTH	DESCRIPTION	STRAT PLOT	NUMBER	TYPE			"N" VALUES	20	40	60	80	100	W _p	W		
66.4	GROUND SURFACE															
0.0	PORTLAND CEMENT CONCRETE (SIDEWALK)															
66.3	(SM/GM) Sand and gravel, some silt (FILL) Grey															
0.2	(SP-SM) Sand, some silt, trace gravel (FILL) Brown Moist		1	GRAB	-	66										
65.7	END OF COREHOLE															
0.7	NOTES: 1. Corehole continued on Record of Drillhole 17-B20D.															

GTA-MTO 001 N:\ACTIVE\SPATIAL_IMMTO\HWY417REHAB&WIDENING\02_DATA\GINT\1655214.GPJ GAL-GTA.GDT 6/12/19 JM

+³, ×³: Numbers refer to Sensitivity ○ 3% STRAIN AT FAILURE

PROJECT <u>1655214-1120</u>	RECORD OF COREHOLE No 17-B21	SHEET 1 OF 1	METRIC
G.W.P. <u>4173-15-00</u>	LOCATION <u>N 5029615.6; E 366862.6 NAD 83 MTM ZONE 9 (LAT. 45.403736; LONG. -75.707207)</u>	ORIGINATED BY <u>DWM</u>	
DIST <u>Eastern</u> HWY <u>417</u>	BOREHOLE TYPE <u>Portable Drill/Hydro-excavation</u>	COMPILED BY <u>ZS</u>	
DATUM <u>Geodetic</u>	DATE <u>March 28, 2017</u>	CHECKED BY <u>KCP</u>	

SOIL PROFILE		SAMPLES			GROUND WATER CONDITIONS	ELEVATION SCALE	DYNAMIC CONE PENETRATION RESISTANCE PLOT					PLASTIC NATURAL LIQUID LIMIT MOISTURE LIMIT CONTENT			UNIT WEIGHT γ kN/m ³	REMARKS & GRAIN SIZE DISTRIBUTION (%) GR SA SI CL
ELEV DEPTH	DESCRIPTION	STRAT PLOT	NUMBER	TYPE			"N" VALUES	SHEAR STRENGTH kPa					WATER CONTENT (%)			
						20	40	60	80	100	W _p	W	W _L			
66.4	GROUND SURFACE															
0.0	PORTLAND CEMENT CONCRETE (SIDEWALK)															
66.2																
66.1	(SP) Gravelly sand (FILL) Grey															
0.3	(SP-SM) Sand, some silt, trace gravel (FILL) Brown															
65.7																
0.7	END OF COREHOLE															

GTA-MTO 001 N:\ACTIVE\SPATIAL_IMMTO\HWY417REHAB&WIDENING02_DATA\GINT\1655214.GPJ GAL-GTA.GDT 6/12/19 JM

PROJECT <u>1655214-1120</u>	RECORD OF COREHOLE No 17-B22	SHEET 1 OF 1	METRIC
G.W.P. <u>4173-15-00</u>	LOCATION <u>N 5029618.7; E 366861.3 NAD 83 MTM ZONE 9 (LAT. 45.403764; LONG. -75.707224)</u>	ORIGINATED BY <u>DWM</u>	
DIST <u>Eastern</u> HWY <u>417</u>	BOREHOLE TYPE <u>Portable Drill/Hydro-excavation</u>	COMPILED BY <u>ZS</u>	
DATUM <u>Geodetic</u>	DATE <u>March 28, 2017</u>	CHECKED BY <u>KCP</u>	

SOIL PROFILE		SAMPLES			GROUND WATER CONDITIONS	ELEVATION SCALE	DYNAMIC CONE PENETRATION RESISTANCE PLOT					PLASTIC NATURAL LIQUID LIMIT			UNIT WEIGHT	REMARKS & GRAIN SIZE DISTRIBUTION (%)
ELEV DEPTH	DESCRIPTION	STRAT PLOT	NUMBER	TYPE			"N" VALUES	20	40	60	80	100	W _p	W		
66.3	GROUND SURFACE															
0.0	PORTLAND CEMENT CONCRETE (SIDEWALK)															
66.1	(SP) Gravelly sand (FILL) Grey															
66.0	(SP-SM) Sand, some silt, trace gravel (FILL) Brown Moist		1	GRAB	-											
65.7	END OF COREHOLE															
0.6																

GTA-MTO 001 N:\ACTIVE\SPATIAL_IMMTO\HWY417REHAB&WIDENING02_DATA\GINT\1655214.GPJ GAL-GTA.GDT 6/12/19 JM

+³, ×³: Numbers refer to Sensitivity ○ 3% STRAIN AT FAILURE

PROJECT <u>1655214-1120</u>	RECORD OF COREHOLE No 17-B23	SHEET 1 OF 1	METRIC
G.W.P. <u>4173-15-00</u>	LOCATION <u>N 5029621.8; E 366859.9 NAD 83 MTM ZONE 9 (LAT. 45.403792; LONG. -75.707241)</u>	ORIGINATED BY <u>DWM</u>	
DIST <u>Eastern</u> HWY <u>417</u>	BOREHOLE TYPE <u>Portable Drill/Hydro-excavation</u>	COMPILED BY <u>ZS</u>	
DATUM <u>Geodetic</u>	DATE <u>March 28, 2017</u>	CHECKED BY <u>KCP</u>	

SOIL PROFILE		SAMPLES			GROUND WATER CONDITIONS	ELEVATION SCALE	DYNAMIC CONE PENETRATION RESISTANCE PLOT					PLASTIC LIMIT NATURAL MOISTURE CONTENT LIQUID LIMIT			UNIT WEIGHT γ kN/m ³	REMARKS & GRAIN SIZE DISTRIBUTION (%) GR SA SI CL
ELEV DEPTH	DESCRIPTION	STRAT PLOT	NUMBER	TYPE			"N" VALUES	20	40	60	80	100	W _p	W		
66.3	GROUND SURFACE															
0.0	PORTLAND CEMENT CONCRETE (SIDEWALK)															
66.2	(SP) Gravelly sand (FILL) Grey															
0.1																
66.0	(SP-SM) Sand, some silt, trace gravel (FILL) Brown Moist		1	GRAB	-											
0.3																
65.7	END OF COREHOLE															
0.6																

GTA-MTO 001 N:\ACTIVE\SPATIAL_IMMTO\HWY417REHAB&WIDENING02_DATA\GINT\1655214.GPJ GAL-GTA.GDT 6/12/19 JM

+³, ×³: Numbers refer to Sensitivity ○ 3% STRAIN AT FAILURE

PROJECT <u>1655214-1120</u>	RECORD OF COREHOLE No 17-B24	SHEET 1 OF 1	METRIC
G.W.P. <u>4173-15-00</u>	LOCATION <u>N 5029624.3; E 366858.8 NAD 83 MTM ZONE 9 (LAT. 45.403814; LONG. -75.707255)</u>	ORIGINATED BY <u>DWM</u>	
DIST <u>Eastern</u> HWY <u>417</u>	BOREHOLE TYPE <u>Portable Drill/Hydro-excavation</u>	COMPILED BY <u>ZS</u>	
DATUM <u>Geodetic</u>	DATE <u>March 28, 2017</u>	CHECKED BY <u>KCP</u>	

ELEV DEPTH	SOIL PROFILE DESCRIPTION	STRAT PLOT	SAMPLES			GROUND WATER CONDITIONS	ELEVATION SCALE	DYNAMIC CONE PENETRATION RESISTANCE PLOT					PLASTIC LIMIT W _p	NATURAL MOISTURE CONTENT W	LIQUID LIMIT W _L	UNIT WEIGHT γ kN/m ³	REMARKS & GRAIN SIZE DISTRIBUTION (%) GR SA SI CL
			NUMBER	TYPE	"N" VALUES			20	40	60	80	100					
66.3	GROUND SURFACE																
0.0	PORTLAND CEMENT CONCRETE (SIDEWALK)																
66.1	(SP) Gravelly sand (FILL) Grey Moist		1	GRAB	-												
66.0	(SP-SM) Sand, some silt, trace gravel (FILL) Brown Moist		2	GRAB	-												
65.7	END OF COREHOLE																
0.6	NOTES: 1. Corehole continued on Record of Drillhole 17-B24D.																

GTA-MTO 001 N:\ACTIVE\SPATIAL_IMMTO\HWY417REHAB&WIDENING02_DATA\GINT\1655214.GPJ GAL-GTA.GDT 6/12/19 JM

+³, ×³: Numbers refer to Sensitivity ○ 3% STRAIN AT FAILURE

PROJECT: 1655214-1120
 LOCATION: N 5029624.3 ; E 366858.8
 INCLINATION: -69° AZIMUTH:

RECORD OF DRILLHOLE: 17-B24D

SHEET 1 OF 1
 DATUM: Geodetic

DRILLING DATE: March 29, 2017
 DRILL RIG: Portable Drill
 DRILLING CONTRACTOR: CCC

DEPTH SCALE METRES	DRILLING RECORD	DESCRIPTION	SYMBOLIC LOG	ELEV. DEPTH (m)	RUN No.	NOTE: For abbreviations, symbols and descriptions refer to LITHOLOGICAL AND GEOTECHNICAL ROCK DESCRIPTION TERMINOLOGY										FEATURES							
						RECOVERY		R.Q.D. %	FRACT. INDEX PER	DISCONTINUITY DATA		HYDRAULIC CONDUCTIVITY K, cm/sec		WEATHERING INDEX									
						TOTAL CORE %	SOLID CORE %			TYPE AND SURFACE DESCRIPTION	Jr	Ja	W1	W2	W3		W4	W5	W6				
		TOP OF FOOTING		65.73																			
1	Portable Drill BQ Core	PORTLAND CEMENT CONCRETE (FOOTING)		0.63	C1	100																	
2		Limestone (BEDROCK), with black shale partings Slightly weathered Thinly to medium bedded Grey Fine grained Non-porous Medium strong to strong		64.85 1.57	C1 C2	0 0																	
		END OF DRILLHOLE		64.14 2.33																			
3																							
4																							
5																							

GTA-RCK 031 N:\ACTIVE\SPATIAL_IMMTO\HWY417\REHAB&WIDENING\02_DATA\GINT\1655214.GPJ GAL-MISS.GDT 6/12/19 JM

PROJECT 1655214-1120 **RECORD OF BOREHOLE No 17-121** **SHEET 1 OF 2** **METRIC**
G.W.P. 4173-15-00 **LOCATION** N 5029588.1; E 366875.8 NAD 83 MTM ZONE 9 (LAT. 45.403487; LONG. -75.707042) **ORIGINATED BY** DWM
DIST Eastern **HWY** 417 **BOREHOLE TYPE** Continuous 50 mm Diam. Split Spoon/NQ Core **COMPILED BY** ZS
DATUM Geodetic **DATE** March 31, 2017 **CHECKED BY** KCP

SOIL PROFILE		SAMPLES			GROUND WATER CONDITIONS	ELEVATION SCALE	DYNAMIC CONE PENETRATION RESISTANCE PLOT					PLASTIC LIMIT W _p	NATURAL MOISTURE CONTENT W	LIQUID LIMIT W _L	UNIT WEIGHT γ	REMARKS & GRAIN SIZE DISTRIBUTION (%)								
ELEV DEPTH	DESCRIPTION	STRAT PLOT	NUMBER	TYPE			"N" VALUES	20	40	60	80						100	20	40	60	80	100	25	50
66.6	GROUND SURFACE																							
0.0	PORTLAND CEMENT CONCRETE (SIDEWALK)																							
66.4																								
66.3	(SP) Gravelly sand (FILL) Grey																							
0.3	(SP-SM) Sand, trace gravel and silt, contains organic matter (FILL) Compact Brown Dry		1	SS	11																			9 81 8 2
65.7			2	SS	25/0.05																			
0.9	Limestone (BEDROCK) Bedrock cored from depths of 0.9 m to 4.1 m For bedrock coring details refer to Record of Drillhole 17-121		C1	RC	REC 86%																			RQD = 53%
			C2	RC	REC 98%																			RQD = 79%
			C3	RC	REC 92%																			RQD = 56%
62.5	END OF BOREHOLE																							
4.1	NOTES: 1. Water level in well screen at a depth of 2.5 m below ground surface (Elev. 64.1 m), measured on October 27, 2017.																							

GTA-MTO 001 N:\ACTIVE\SPATIAL_IMMTO\HWY417REHAB&WIDENING\02_DATA\GINT\1655214.GPJ GAL-GTA.GDT 6/12/19 JM

 +³, ×³: Numbers refer to Sensitivity ○ 3% STRAIN AT FAILURE

PROJECT 1655214-1120	RECORD OF BOREHOLE No 17-122	SHEET 1 OF 2	METRIC
G.W.P. 4173-15-00	LOCATION N 5029591.2; E 366891.0 NAD 83 MTM ZONE 9 (LAT. 45.403514; LONG. -75.706847)	ORIGINATED BY DWM	
DIST Eastern HWY 417	BOREHOLE TYPE Continuous 50 mm Diam. Split Spoon/NQ Core	COMPILED BY ZS	
DATUM Geodetic	DATE April 3, 2017	CHECKED BY KCP	

SOIL PROFILE		SAMPLES			GROUND WATER CONDITIONS	ELEVATION SCALE	DYNAMIC CONE PENETRATION RESISTANCE PLOT					PLASTIC LIMIT W _p	NATURAL MOISTURE CONTENT W	LIQUID LIMIT W _L	UNIT WEIGHT γ	REMARKS & GRAIN SIZE DISTRIBUTION (%)				
ELEV DEPTH	DESCRIPTION	STRAT PLOT	NUMBER	TYPE			"N" VALUES	SHEAR STRENGTH kPa									WATER CONTENT (%)			
						20	40	60	80	100	20	40	60	80	100	25	50	75		GR SA SI CL
66.7	GROUND SURFACE																			
0.0	PORTLAND CEMENT CONCRETE (SIDEWALK)																			
66.6	(SP) Gravelly sand (FILL) Grey																			
0.1																				
66.4	(SP) Sand, some gravel, trace silt (FILL) Compact Grey brown Dry																			
0.3			1	SS		13														
65.7			2	SS		50/0.05														
1.0	Limestone (BEDROCK) Bedrock cored from depths of 1.0 m to 4.2 m For bedrock coring details refer to Record of Drillhole 17-122		C1	RC		REC 96%														RQD = 80%
			C2	RC		REC 99%														RQD = 80%
			C3	RC		REC 100%														RQD = 90%
62.5	END OF BOREHOLE																			
4.2																				

GTA-MTO 001 N:\ACTIVE\SPATIAL_IMMTO\HWY417REHAB&WIDENING02_DATA\GINT\1655214.GPJ GAL-GTA.GDT 6/12/19 JM

+³, ×³: Numbers refer to Sensitivity ○ 3% STRAIN AT FAILURE

PROJECT <u>1655214-1120</u>	RECORD OF BOREHOLE No 17-123	SHEET 1 OF 2	METRIC
G.W.P. <u>4173-15-00</u>	LOCATION <u>N 5029627.2; E 366858.8 NAD 83 MTM ZONE 9 (LAT. 45.403840; LONG. -75.707255)</u>	ORIGINATED BY <u>KM</u>	
DIST <u>Eastern</u> HWY <u>417</u>	BOREHOLE TYPE <u>Hydro-excavation/NQ Core</u>	COMPILED BY <u>ZS</u>	
DATUM <u>Geodetic</u>	DATE <u>April 6/10, 2017</u>	CHECKED BY <u>KCP</u>	

ELEV DEPTH	SOIL PROFILE DESCRIPTION	STRAT PLOT	SAMPLES			GROUND WATER CONDITIONS	ELEVATION SCALE	DYNAMIC CONE PENETRATION RESISTANCE PLOT					PLASTIC LIMIT W _p	NATURAL MOISTURE CONTENT W	LIQUID LIMIT W _L	UNIT WEIGHT γ	REMARKS & GRAIN SIZE DISTRIBUTION (%)	
			NUMBER	TYPE	"N" VALUES			SHEAR STRENGTH kPa										WATER CONTENT (%)
								20	40	60	80	100						GR SA SI CL
66.3	GROUND SURFACE																	
0.0	PORTLAND CEMENT CONCRETE (SIDEWALK)																	
66.2	(SP) Gravelly sand (FILL) Grey																	
0.1																		
66.0																		
0.3	(SP) Sand, trace gravel and silt, contains organic matter (FILL) Brown Moist		1	GRAB	-		66											
65.5																		
0.8	(GP) Gravel and cobbles (FILL)																	
65.2			2	RC	DD													
1.2	Limestone (BEDROCK)																	
	Bedrock cored from depths of 1.2 m to 4.8 m		C1	RC	REC 65%		65											RQD = 0%
	For bedrock coring details refer to Record of Drillhole 17-123		C2	RC	REC 95%													RQD = 77%
			C3	RC	REC 99%		64											RQD = 92%
			C4	RC	REC 97%		63											RQD = 97%
							62											
61.5																		
4.8	END OF BOREHOLE																	

GTA-MTO 001 N:\ACTIVE\SPATIAL_IMMTO\HWY417REHAB&WIDENING\02_DATA\GINT\1655214.GPJ GAL-GTA.GDT 6/12/19 JM

+³, ×³: Numbers refer to Sensitivity ○ 3% STRAIN AT FAILURE

PROJECT <u>1655214-1120</u>	RECORD OF BOREHOLE No 17-124	SHEET 1 OF 2	METRIC
G.W.P. <u>4173-15-00</u>	LOCATION <u>N 5029631.8; E 366873.5 NAD 83 MTM ZONE 9 (LAT. 45.403880; LONG. -75.707066)</u>	ORIGINATED BY <u>DWM</u>	
DIST <u>Eastern</u> HWY <u>417</u>	BOREHOLE TYPE <u>Hydro-excavation/NQ Core</u>	COMPILED BY <u>ZS</u>	
DATUM <u>Geodetic</u>	DATE <u>April 6/10, 2017</u>	CHECKED BY <u>KCP</u>	

ELEV DEPTH	SOIL PROFILE DESCRIPTION	STRAT PLOT	SAMPLES			GROUND WATER CONDITIONS	ELEVATION SCALE	DYNAMIC CONE PENETRATION RESISTANCE PLOT					PLASTIC LIMIT W _p	NATURAL MOISTURE CONTENT W	LIQUID LIMIT W _L	UNIT WEIGHT γ	REMARKS & GRAIN SIZE DISTRIBUTION (%)						
			NUMBER	TYPE	"N" VALUES			SHEAR STRENGTH kPa										WATER CONTENT (%)					
								20	40	60	80	100						GR	SA	SI	CL		
66.4	GROUND SURFACE																						
0.0	PORTLAND CEMENT CONCRETE																						
66.2	(SP) Gravelly sand (FILL) Grey																						
66.1	(SP-SM) Sand, some gravel, trace silt (FILL) Moist		1	GRAB	-		66												11	78	9	2	
65.7	(GP) Gravel and cobbles (FILL)		2	GRAB	-																		
65.5	Limestone (BEDROCK)																						
0.9	Bedrock cored from depths 0.9 m to 4.4 m For bedrock coring details refer to Record of Drillhole 17-124		C1	RC	REC 96%		65															RQD = 69%	
			C2	RC	REC 96%		64																RQD = 94%
			C3	RC	REC 100%		63																RQD = 100%
62.0	END OF BOREHOLE						62																
4.4	NOTES: 1. Water level in well screen at a depth of 2.2 m below ground surface (Elev. 64.2 m), measured on October 27, 2017.																						

GTA-MTO 001 N:\ACTIVE\SPATIAL_IMMTO\HWY417REHAB&WIDENING\02_DATA\GINT\1655214.GPJ GAL-GTA.GDT 6/12/19 JM

+³, ×³: Numbers refer to Sensitivity ○ 3% STRAIN AT FAILURE

PROJECT 1655214-1120 **RECORD OF BOREHOLE No 18-1201** SHEET 1 OF 2 **METRIC**
 G.W.P. 4173-15-00 LOCATION N 5029623.2; E 366850.6 NAD 83 MTM ZONE 9 (LAT. 45.403800; LONG. -75.707360) ORIGINATED BY RI
 DIST Eastern HWY 417 BOREHOLE TYPE Rotary Drill/Wash Boring, HW Casing/HQ Core COMPILED BY ZS
 DATUM Geodetic DATE April 12, 2019 CHECKED BY KCP

SOIL PROFILE		SAMPLES			GROUND WATER CONDITIONS	ELEVATION SCALE	DYNAMIC CONE PENETRATION RESISTANCE PLOT					PLASTIC LIMIT W _p	NATURAL MOISTURE CONTENT W	LIQUID LIMIT W _L	UNIT WEIGHT γ	REMARKS & GRAIN SIZE DISTRIBUTION (%)			
ELEV DEPTH	DESCRIPTION	STRAT PLOT	NUMBER	TYPE			"N" VALUES	20	40	60	80						100	25	50
68.4 0.0	GROUND SURFACE (SW-SM) Sand, trace silt (FILL) Brown Moist to wet		1	SS	1														
			2	SS	1														
65.5 3.0	PORTLAND CEMENT CONCRETE (FOOTING)		1	RC	-														
			2A	RC	-														
64.5 3.9	Limestone (BEDROCK) Bedrock cored from depths 3.9 m to 5.6 m For bedrock coring details refer to Record of Drillhole 18-1201		2B	RC	REC 100%														RQD = 61%
			3	RC	REC 97%														RQD = 88%
62.8 5.6	END OF BOREHOLE NOTE: 1. A reduced SPT hammer drop of 0.61 m was used for all split spoon samples "N" values are not representative of ASTM D1586 SPTN and should be interpreted in consideration of this reduced energy.																		

GTA-MTO 001 N:\ACTIVE\SPATIAL_IMMTO\HWY417REHAB&WIDENING\02_DATA\GINT\1655214.GPJ GAL-GTA.GDT 6/12/19 JM

+³, ×³: Numbers refer to Sensitivity ○ 3% STRAIN AT FAILURE

PROJECT <u>1655214-1120</u>	RECORD OF BOREHOLE No 18-1202	SHEET 1 OF 2	METRIC
G.W.P. <u>4173-15-00</u>	LOCATION <u>N 5029588.0; E 366868.8 NAD 83 MTM ZONE 9 (LAT. 45.403480; LONG. -75.707130)</u>	ORIGINATED BY <u>RI/RK</u>	
DIST <u>Eastern</u> HWY <u>417</u>	BOREHOLE TYPE <u>Rotary Drill/Wash Boring, HW Casing/HQ Core</u>	COMPILED BY <u>ZS</u>	
DATUM <u>Geodetic</u>	DATE <u>April 11, 2019</u>	CHECKED BY <u>KCP</u>	

ELEV DEPTH	SOIL PROFILE DESCRIPTION	STRAT PLOT	SAMPLES			GROUND WATER CONDITIONS	ELEVATION SCALE	DYNAMIC CONE PENETRATION RESISTANCE PLOT					PLASTIC LIMIT W _p	NATURAL MOISTURE CONTENT W	LIQUID LIMIT W _L	UNIT WEIGHT γ kN/m ³	REMARKS & GRAIN SIZE DISTRIBUTION (%) GR SA SI CL
			NUMBER	TYPE	"N" VALUES			SHEAR STRENGTH kPa									
							20	40	60	80	100						
69.5 0.0	GROUND SURFACE (SW) Sand (FILL) Brown Moist to wet		1	SS	3												
							69										
			2	SS	1												
							68										
							67										
66.9 2.8	(SW) Sand, some gravel, contains cobbles (FILL) Brown Moist PORTLAND CEMENT CONCRETE (FOOTING)		1	RC	-												
			2	RC	-												
			3A	RC	-												
			3B	RC	-												
							66										
65.7 3.8	Limestone (BEDROCK) Bedrock cored from depths 3.8 m to 5.7 m For bedrock coring details refer to Record of Drillhole 18-1202		4	RC	REC 88%											RQD = 65%	
			5	RC	REC 100%											RQD = 24%	
			6	RC	REC 100%											RQD = 75%	
			7	RC	REC 100%											RQD = 100%	
							65										
							64										
63.9 5.7	END OF BOREHOLE NOTE: 1. A reduced SPT hammer drop of 0.61 m was used for all split spoon samples "N" values are not representative of ASTM D1586 SPTN and should be interpreted in consideration of this reduced energy.																

GTA-MTO 001 N:\ACTIVE\SPATIAL_IMMTO\HWY417\REHAB&WIDENING\02_DATA\GINT\1655214.GPJ GAL-GTA.GDT 6/12/19 JM

+³, ×³: Numbers refer to Sensitivity ○ 3% STRAIN AT FAILURE

PROJECT <u>1655214-1120</u>	RECORD OF BOREHOLE No 18-1203	SHEET 1 OF 2	METRIC
G.W.P. <u>4173-15-00</u>	LOCATION <u>N 5029632.6; E 366880.7 NAD 83 MTM ZONE 9 (LAT. 45.403880; LONG. -75.706970)</u>	ORIGINATED BY <u>RI</u>	
DIST <u>Eastern</u> HWY <u>417</u>	BOREHOLE TYPE <u>Rotary Drill/Wash Boring, HW Casing/HQ Core</u>	COMPILED BY <u>ZS</u>	
DATUM <u>Geodetic</u>	DATE <u>April 15, 2019</u>	CHECKED BY <u>KCP</u>	

ELEV DEPTH	SOIL PROFILE DESCRIPTION	STRAT PLOT	SAMPLES			GROUND WATER CONDITIONS	ELEVATION SCALE	DYNAMIC CONE PENETRATION RESISTANCE PLOT					PLASTIC LIMIT W _p	NATURAL MOISTURE CONTENT W	LIQUID LIMIT W _L	UNIT WEIGHT γ kN/m ³	REMARKS & GRAIN SIZE DISTRIBUTION (%) GR SA SI CL
			NUMBER	TYPE	"N" VALUES			SHEAR STRENGTH kPa									
							20	40	60	80	100						
68.7 0.0	GROUND SURFACE (SW) Sand (FILL) Brown Moist		1	SS	1												
			2	SS	1											1 96 (3)	
			3	SS	1												
66.7 2.0	(SM/ML) Silty sand to sandy silt, some gravel, contains wood, mortar, organic matter, brick and cobbles (FILL) Compact		4	SS	12												
66.1 2.6	Black to dark brown Moist to wet PORTLAND CEMENT CONCRETE (FOOTING)		5	SS	50/0,10												
			1	RC	-												
			2A	RC	-												
65.0 3.7	Limestone (BEDROCK) Bedrock cored from depths 3.7 m to 5.5 m For bedrock coring details refer to Record of Drillhole 18-1203		2B	RC	REC 100%											RQD = 96%	
			3	RC	REC 74%											RQD = 52%	
			4	RC	REC 100%											RQD = 100%	
63.2 5.5	END OF BOREHOLE NOTE: 1. A reduced SPT hammer drop of 0.61 m was used for all split spoon samples "N" values are not representative of ASTM D1586 SPTN and should be interpreted in consideration of this reduced energy.																

GTA-MTO 001 N:\ACTIVE\SPATIAL_IMMTO\HWY417REHAB&WIDENING02_DATA\GINT\1655214.GPJ GAL-GTA.GDT 6/12/19 JM

+³, ×³: Numbers refer to Sensitivity ○ 3% STRAIN AT FAILURE

PROJECT <u>1655214-1120</u>	RECORD OF BOREHOLE No 18-1204	SHEET 1 OF 2	METRIC
G.W.P. <u>4173-15-00</u>	LOCATION <u>N 5029597.6; E 366900.1 NAD 83 MTM ZONE 9 (LAT. 45.403560; LONG. -75.706730)</u>	ORIGINATED BY <u>RI/RK</u>	
DIST <u>Eastern</u> HWY <u>417</u>	BOREHOLE TYPE <u>Rotary Drill/Wash Boring, NW Casing/NQ Core</u>	COMPILED BY <u>ZS</u>	
DATUM <u>Geodetic</u>	DATE <u>April 10, 2019</u>	CHECKED BY <u>KCP</u>	

ELEV DEPTH	SOIL PROFILE DESCRIPTION	STRAT PLOT	SAMPLES			GROUND WATER CONDITIONS	ELEVATION SCALE	DYNAMIC CONE PENETRATION RESISTANCE PLOT					PLASTIC LIMIT W _p	NATURAL MOISTURE CONTENT W	LIQUID LIMIT W _L	UNIT WEIGHT γ kN/m ³	REMARKS & GRAIN SIZE DISTRIBUTION (%) GR SA SI CL
			NUMBER	TYPE	"N" VALUES			SHEAR STRENGTH kPa									
								20	40	60	80	100					
70.5	GROUND SURFACE																
0.0	(SM) Silty sand, contains organic matter (FILL) Brown to dark brown Moist		1	SS	3		70										
69.9	(SW) Sand (FILL) Brown Moist to wet		2	SS	2		69										
0.6							68										
67.3			3	SS	1		67										3 94 (3)
3.2	BOULDER						66										
66.7							65										
3.8	(SW) Sand, contains cobbles (FILL) Brown Moist to wet		1	RC	-		64										
66.2							63										
4.3	PORTLAND CEMENT CONCRETE (FOOTING)		2A	RC	-		62										
65.2							61										
5.3	Limestone (BEDROCK) Bedrock cored from depths 5.3 m to 7.1 m For bedrock coring details refer to Record of Drillhole 18-1204		2B	RC	REC 100%		60										RQD = 0%
			3	RC	REC 93%		59										RQD = 81%
63.4			4	RC	REC 100%		58										RQD = 100%
7.1	END OF BOREHOLE NOTE: 1. A reduced SPT hammer drop of 0.61 m was used for all split spoon samples "N" values are not representative of ASTM D1586 SPTN and should be interpreted in consideration of this reduced energy.						57										

GTA-MTO 001 N:\ACTIVE\SPATIAL_IMMTO\HWY417REHAB&WIDENING\02_DATA\GINT\1655214.GPJ GAL-GTA.GDT 6/12/19 JM

+³, ×³: Numbers refer to Sensitivity ○ 3% STRAIN AT FAILURE

PROJECT <u>1655214-1120</u>	RECORD OF BOREHOLE No 18-1205	SHEET 1 OF 1	METRIC
G.W.P. <u>4173-15-00</u>	LOCATION <u>N 5029618.3; E 366850.1 NAD 83 MTM ZONE 9 (LAT. 45.403750; LONG. -75.707360)</u>	ORIGINATED BY <u>DJG</u>	
DIST <u>Eastern</u> HWY <u>417</u>	BOREHOLE TYPE <u>Power Auger, 200 mm Diam. (Hollow Stem)</u>	COMPILED BY <u>ZS</u>	
DATUM <u>Geodetic</u>	DATE <u>October 11, 2018</u>	CHECKED BY <u>KCP</u>	

ELEV DEPTH	SOIL PROFILE DESCRIPTION	STRAT PLOT	SAMPLES			GROUND WATER CONDITIONS	ELEVATION SCALE	DYNAMIC CONE PENETRATION RESISTANCE PLOT					PLASTIC LIMIT W _p	NATURAL MOISTURE CONTENT W	LIQUID LIMIT W _L	UNIT WEIGHT γ	REMARKS & GRAIN SIZE DISTRIBUTION (%)
			NUMBER	TYPE	"N" VALUES			SHEAR STRENGTH kPa									
							20	40	60	80	100						
71.9	GROUND SURFACE																
0.0	ASPHALTIC CONCRETE																
0.2	PORTLAND CEMENT CONCRETE, with rebar																
0.5	(SP/GP) Sand and gravel (FILL) Grey Moist		1	GS	-												
0.8	(SP/SM) Sand, trace silt and gravel Loose to very dense Brown Moist		2	SS	21		71										
			3	SS	42		70										
			4	SS	41												
			5	SS	61												
			6	SS	44												
			7	SS	10											3 89 (8)	
			8	SS	4												
			9	SS	9												
65.0	END OF BOREHOLE AUGER REFUSAL						65										
6.9	NOTES: 1. Borehole dry upon completion of drilling.																

GTA-MTO 001 N:\ACTIVE\SPATIAL_IMMTO\HWY417REHAB&WIDENING02_DATA\GINT\1655214.GPJ GAL-GTA.GDT 6/12/19 JM

+³, ×³: Numbers refer to Sensitivity ○ 3% STRAIN AT FAILURE

PROJECT 1655214-1120 **RECORD OF BOREHOLE No 18-1206** **SHEET 1 OF 1** **METRIC**
G.W.P. 4173-15-00 **LOCATION** N 5029601.2; E 366853.7 NAD 83 MTM ZONE 9 (LAT. 45.403600; LONG. -75.707320) **ORIGINATED BY** RI
DIST Eastern **HWY** 417 **BOREHOLE TYPE** Power Auger, 200 mm Diam. (Hollow Stem) **COMPILED BY** ZS
DATUM Geodetic **DATE** October 2 and 3, 2018 **CHECKED BY** KCP

SOIL PROFILE		SAMPLES			GROUND WATER CONDITIONS	ELEVATION SCALE	DYNAMIC CONE PENETRATION RESISTANCE PLOT					PLASTIC NATURAL LIQUID LIMIT			UNIT WEIGHT γ	REMARKS & GRAIN SIZE DISTRIBUTION (%)		
ELEV DEPTH	DESCRIPTION	STRAT PLOT	NUMBER	TYPE			"N" VALUES	20	40	60	80	100	W _p	W			W _L	GR
72.1	GROUND SURFACE																	
0.0	ASPHALTIC CONCRETE																	
71.9																		
0.2	(SP/GP) Sand and gravel (FILL) Grey Moist																	
71.3																		
0.8	(SP) Sand, some gravel (FILL) Loose Brown Moist		1	SS	6													
70.9																		
1.4	(CL/CI) Sandy clayey silt, contains ash/asphalt debris and organic matter (FILL) Firm Grey brown Moist		2	SS	67													
	(SM) Sand, some silt and gravel (FILL) Very dense Brown Moist		3	SS	67													
			4	SS	91													
			5	SS	88													
			6	SS	46													
			7	SS	19													
66.8			8	SS	60/0.13													
5.3	(SP) Sand (FILL) Compact Brown Moist																	
65.8																		
6.3	Weathered Shale (BEDROCK)																	
65.2																		
6.9	END OF BOREHOLE AUGER REFUSAL																	
	NOTES: 1. Borehole dry upon completion of drilling.																	

GTA-MTO 001 N:\ACTIVE\SPATIAL_IMMTO\HWY417REHAB&WIDENING02_DATA\GINT\1655214.GPJ GAL-GTA.GDT 6/12/19 JM

PROJECT <u>1655214-1120</u>	RECORD OF BOREHOLE No 18-1207	SHEET 1 OF 1	METRIC
G.W.P. <u>4173-15-00</u>	LOCATION <u>N 5029618.2; E 366891.1 NAD 83 MTM ZONE 9 (LAT. 45.403750; LONG. -75.706840)</u>	ORIGINATED BY <u>DJG</u>	
DIST <u>Eastern</u> HWY <u>417</u>	BOREHOLE TYPE <u>Power Auger, 200 mm Diam. (Hollow Stem)</u>	COMPILED BY <u>ZS</u>	
DATUM <u>Geodetic</u>	DATE <u>October 4, 2018</u>	CHECKED BY <u>KCP</u>	

ELEV DEPTH	SOIL PROFILE DESCRIPTION	STRAT PLOT	SAMPLES			GROUND WATER CONDITIONS	ELEVATION SCALE	DYNAMIC CONE PENETRATION RESISTANCE PLOT					UNIT WEIGHT γ kN/m ³	REMARKS & GRAIN SIZE DISTRIBUTION (%) GR SA SI CL
			NUMBER	TYPE	"N" VALUES			SHEAR STRENGTH kPa						
							20 40 60 80 100	○ UNCONFINED + FIELD VANE ● QUICK TRIAXIAL × REMOULDED						
							20 40 60 80 100	PLASTIC LIMIT W _p	NATURAL MOISTURE CONTENT W	LIQUID LIMIT W _L				
								WATER CONTENT (%)						
								25	50	75				
72.6	GROUND SURFACE													
0.0	ASPHALTIC CONCRETE													
72.3														
0.3	(SP/GP) Sand and gravel (FILL) Grey Moist		1	GS	-		72							
71.8														
0.8	(SP-SM) Sand, trace silt (FILL) Very dense to loose Brown Moist		2	SS	50		71							
			3	SS	40									
			4	SS	52		70						2 92 (6)	
			5	SS	30									
			6	SS	30		69							
			7	SS	4		68						1 96 (3)	
			8	SS	4		67							
66.5														
6.1	(SM) Gravelly SAND, some silt, trace clay, contains shale bedrock fragments and organic matter (TILL) Loose Grey brown Wet		9	SS	6		66						25 55 14 6	
65.7			10	SS	60									
6.9	END OF BOREHOLE AUGER REFUSAL													
	NOTES: 1. Water level in well screen at a depth of 6.9 m below ground surface (Elev. 65.7 m), measured on Dec. 6, 2018.													

GTA-MTO 001 N:\ACTIVE\SPATIAL_IMMTO\HWY417REHAB&WIDENING\02_DATA\GINT\1655214.GPJ GAL-GTA.GDT 6/12/19 JM

+³, ×³: Numbers refer to Sensitivity ○ 3% STRAIN AT FAILURE

PROJECT 1655214-1120 **RECORD OF BOREHOLE No 18-1208** SHEET 1 OF 1 **METRIC**
G.W.P. 4173-15-00 **LOCATION** N 5029602.4; E 366898.5 NAD 83 MTM ZONE 9 (LAT. 45.403610; LONG. -75.706750) **ORIGINATED BY** DJG
DIST Eastern **HWY** 417 **BOREHOLE TYPE** Power Auger, 200 mm Diam. (Hollow Stem) **COMPILED BY** ZS
DATUM Geodetic **DATE** October 9, 2018 **CHECKED BY** KCP

SOIL PROFILE		SAMPLES			GROUND WATER CONDITIONS	ELEVATION SCALE	DYNAMIC CONE PENETRATION RESISTANCE PLOT					PLASTIC LIMIT W _p	NATURAL MOISTURE CONTENT W	LIQUID LIMIT W _L	UNIT WEIGHT γ	REMARKS & GRAIN SIZE DISTRIBUTION (%)								
ELEV DEPTH	DESCRIPTION	STRAT PLOT	NUMBER	TYPE			"N" VALUES	SHEAR STRENGTH kPa									WATER CONTENT (%)							
						20	40	60	80	100	20	40	60	80	100	25	50	75		GR	SA	SI	CL	
72.9	GROUND SURFACE																							
0.0	ASPHALTIC CONCRETE																							
72.5	PORTLAND CEMENT CONCRETE, with rebar																							
0.4	(SP/GP) Sand and gravel (FILL) Grey Moist		1	GS	-																			
72.1	(SP) Sand, trace silt and gravel (FILL) Very dense to compact Brown Dry		2	SS	55																			
0.8			3	SS	51																			
			4	SS	52																			
			5	SS	35																			
			6	SS	39																			
			7	SS	12																			2 96 (2)
67.6	(CL) Sandy clayey silt (FILL) Firm Brown Moist		8	SS	2																			2 45 32 21
5.3			9	SS	2																			
67.0	(SP) Sand, trace silt (FILL) Very loose to compact Brown Moist		10	SS	24																			
5.9																								
65.3	END OF BOREHOLE AUGER REFUSAL																							
7.6																								

GTA-MTO 001 N:\ACTIVE\SPATIAL_IMMTO\HWY417REHAB&WIDENING02_DATA\GINT\1655214.GPJ GAL-GTA.GDT 6/12/19 JM

+³, ×³: Numbers refer to Sensitivity ○ 3% STRAIN AT FAILURE

PROJECT <u>1655214-1120</u>	RECORD OF BOREHOLE No 18-1209	SHEET 1 OF 1	METRIC
G.W.P. <u>4173-15-00</u>	LOCATION <u>N 5029514.3; E 366806.2 NAD 83 MTM ZONE 9 (LAT. 45.402820; LONG. -75.707940)</u>	ORIGINATED BY <u>PAH</u>	
DIST <u>Eastern</u> HWY <u>417</u>	BOREHOLE TYPE <u>Power Auger, 200 mm Diam. (Hollow Stem)</u>	COMPILED BY <u>ZS</u>	
DATUM <u>Geodetic</u>	DATE <u>January 27, 2019</u>	CHECKED BY <u>KCP</u>	

SOIL PROFILE		SAMPLES			GROUND WATER CONDITIONS	ELEVATION SCALE	DYNAMIC CONE PENETRATION RESISTANCE PLOT					PLASTIC LIMIT W _p	NATURAL MOISTURE CONTENT W	LIQUID LIMIT W _L	UNIT WEIGHT γ kN/m ³	REMARKS & GRAIN SIZE DISTRIBUTION (%) GR SA SI CL
ELEV DEPTH	DESCRIPTION	STRAT PLOT	NUMBER	TYPE			"N" VALUES	20	40	60	80					
65.3	GROUND SURFACE															
64.8	ASPHALTIC CONCRETE (40 mm) (SP) Gravelly sand, angular (FILL) Grey		1	GS	-											
64.7			2	GS	-											
64.3	(SM) Silty sand, trace gravel, angular (FILL) Grey brown		3	GS	-											
64.3	END OF BOREHOLE AUGER REFUSAL															
64.3	NOTE: 1. Borehole dry upon completion of drilling															

GTA-MTO 001 N:\ACTIVE\SPATIAL_IMMTO\HWY417REHAB&WIDENING\02_DATA\GINT\1655214.GPJ GAL-GTA.GDT 6/12/19 JM

+³, ×³: Numbers refer to Sensitivity ○ 3% STRAIN AT FAILURE

PROJECT <u>1655214-1120</u>	RECORD OF BOREHOLE No 18-1210	SHEET 1 OF 1	METRIC
G.W.P. <u>4173-15-00</u>	LOCATION <u>N 5029529.9; E 366838.3 NAD 83 MTM ZONE 9 (LAT. 45.402960; LONG. -75.707530)</u>	ORIGINATED BY <u>PAH</u>	
DIST <u>Eastern</u> HWY <u>417</u>	BOREHOLE TYPE <u>Power Auger, 200 mm Diam. (Hollow Stem)</u>	COMPILED BY <u>ZS</u>	
DATUM <u>Geodetic</u>	DATE <u>January 27, 2019</u>	CHECKED BY <u>KCP</u>	

SOIL PROFILE		SAMPLES			GROUND WATER CONDITIONS	ELEVATION SCALE	DYNAMIC CONE PENETRATION RESISTANCE PLOT					PLASTIC NATURAL LIQUID LIMIT MOISTURE LIMIT CONTENT			UNIT WEIGHT γ kN/m ³	REMARKS & GRAIN SIZE DISTRIBUTION (%) GR SA SI CL		
ELEV DEPTH	DESCRIPTION	STRAT PLOT	NUMBER	TYPE			"N" VALUES	20	40	60	80	100	W _p	W			W _L	25
66.0	GROUND SURFACE																	
65.7	ASPHALTIC CONCRETE (50 mm) (SP) Gravelly sand, angular (FILL) Grey		1	GS	-													
65.4	(SM) Silty sand, angular (FILL) Grey brown		2	SS	50/0.225							o						
65.0	END OF BOREHOLE AUGER REFUSAL																	
1.0	NOTE: 1. Borehole dry upon completion of drilling																	

GTA-MTO 001 N:\ACTIVE\SPATIAL_IMMTO\HWY417REHAB&WIDENING\02_DATA\GINT\1655214.GPJ GAL-GTA.GDT 6/12/19 JM

+³, ×³: Numbers refer to Sensitivity ○ 3% STRAIN AT FAILURE

PROJECT <u>1655214-1120</u>	RECORD OF BOREHOLE No 18-1211	SHEET 1 OF 1	METRIC
G.W.P. <u>4173-15-00</u>	LOCATION <u>N 5029545.2; E 366884.1 NAD 83 MTM ZONE 9 (LAT. 45.403090; LONG. -75.706940)</u>	ORIGINATED BY <u>PAH</u>	
DIST <u>Eastern</u> HWY <u>417</u>	BOREHOLE TYPE <u>Power Auger, 200 mm Diam. (Hollow Stem)</u>	COMPILED BY <u>ZS</u>	
DATUM <u>Geodetic</u>	DATE <u>January 27, 2019</u>	CHECKED BY <u>KCP</u>	

ELEV DEPTH	SOIL PROFILE DESCRIPTION	STRAT PLOT	SAMPLES			GROUND WATER CONDITIONS	ELEVATION SCALE	DYNAMIC CONE PENETRATION RESISTANCE PLOT					PLASTIC LIMIT W _p	NATURAL MOISTURE CONTENT W	LIQUID LIMIT W _L	UNIT WEIGHT γ kN/m ³	REMARKS & GRAIN SIZE DISTRIBUTION (%) GR SA SI CL
			NUMBER	TYPE	"N" VALUES			20	40	60	80	100					
66.8	GROUND SURFACE																
66.8	ASPHALTIC CONCRETE (40 mm)		1	GS	-												
66.3	(SW) Gravelly sand (FILL) Grey		2	GS	-												
66.3	(SM) Silty sand, angular (FILL) Very dense Grey brown																
65.2			3	SS	56		66										
65.2			4	SS	50/0.08												
65.2	END OF BOREHOLE AUGER REFUSAL																

GTA-MTO 001 N:\ACTIVE\SPATIAL_IMMTO\HWY417REHAB&WIDENING02_DATA\GINT\1655214.GPJ GAL-GTA.GDT 6/12/19 JM

+³, ×³: Numbers refer to Sensitivity ○ 3% STRAIN AT FAILURE

PROJECT <u>1655214-1120</u>	RECORD OF BOREHOLE No 18-1212	SHEET 1 OF 1	METRIC
G.W.P. <u>4173-15-00</u>	LOCATION <u>N 5029556.0; E 366916.4 NAD 83 MTM ZONE 9 (LAT. 45.403190; LONG. -75.706520)</u>	ORIGINATED BY <u>KM</u>	
DIST <u>Eastern</u> HWY <u>417</u>	BOREHOLE TYPE <u>Power Auger, 200 mm Diam. (Hollow Stem)</u>	COMPILED BY <u>ZS</u>	
DATUM <u>Geodetic</u>	DATE <u>November 19, 2018</u>	CHECKED BY <u>KCP</u>	

SOIL PROFILE		SAMPLES			GROUND WATER CONDITIONS	ELEVATION SCALE	DYNAMIC CONE PENETRATION RESISTANCE PLOT					PLASTIC LIMIT W _p	NATURAL MOISTURE CONTENT W	LIQUID LIMIT W _L	UNIT WEIGHT γ	REMARKS & GRAIN SIZE DISTRIBUTION (%)		
ELEV DEPTH	DESCRIPTION	STRAT PLOT	NUMBER	TYPE			"N" VALUES	20	40	60	80						100	25
67.2	GROUND SURFACE																	
0.0	ASPHALTIC CONCRETE (70 mm)																	
0.1	(GM/SM) Gravel and sand, contains cobbles and boulders (FILL) Dense Brown Moist		1	SS	31													
			2	SS	36													45 37 18 18
65.6	END OF BOREHOLE AUGER REFUSAL		3	SS	50/0.05													
1.6	NOTE: 1. Borehole dry upon completion of drilling																	

GTA-MTO 001 N:\ACTIVE\SPATIAL_IMMTO\HWY417REHAB&WIDENING\02_DATA\GINT\1655214.GPJ GAL-GTA.GDT 6/12/19 JM

PROJECT <u>1655214-1120</u>	RECORD OF BOREHOLE No 18-1213	SHEET 1 OF 1	METRIC
G.W.P. <u>4173-15-00</u>	LOCATION <u>N 5029572.0; E 366933.6 NAD 83 MTM ZONE 9 (LAT. 45.403330; LONG. -75.706300)</u>	ORIGINATED BY <u>IAN</u>	
DIST <u>Eastern</u> HWY <u>417</u>	BOREHOLE TYPE <u>Power Auger, 200 mm Diam. (Hollow Stem)</u>	COMPILED BY <u>ZS</u>	
DATUM <u>Geodetic</u>	DATE <u>November 19, 2018</u>	CHECKED BY <u>KCP</u>	

SOIL PROFILE		SAMPLES			GROUND WATER CONDITIONS	ELEVATION SCALE	DYNAMIC CONE PENETRATION RESISTANCE PLOT					PLASTIC LIMIT W _p	NATURAL MOISTURE CONTENT W	LIQUID LIMIT W _L	UNIT WEIGHT γ	REMARKS & GRAIN SIZE DISTRIBUTION (%) GR SA SI CL				
ELEV DEPTH	DESCRIPTION	STRAT PLOT	NUMBER	TYPE			"N" VALUES	20	40	60	80						100	20	40	60
67.8	GROUND SURFACE																			
0.0 0.1	ASPHALTIC CONCRETE (80 mm) (GM/SM) Gravel and sand, some silt, contains cobbles (FILL) Dense Brown Moist																			
			1	SS	31															
66.4 1.4	END OF BOREHOLE AUGER REFUSAL NOTE: 1. Borehole dry upon completion																			

GTA-MTO 001 N:\ACTIVE\SPATIAL_IMMTO\HWY417REHAB&WIDENING\02_DATA\GINT\1655214.GPJ GAL-GTA.GDT 6/12/19 JM

+³, ×³: Numbers refer to Sensitivity ○ 3% STRAIN AT FAILURE

CH 17B-01 (Dry)
Core Box 1 of 1

Elevation 65.75 m Top Footing

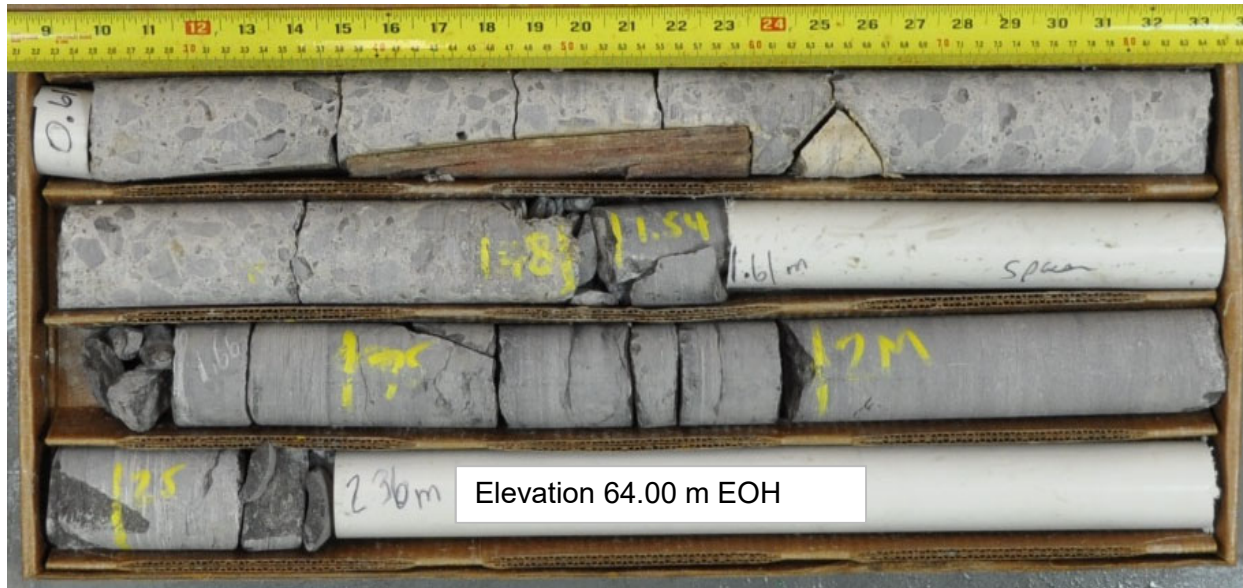

Foundation Investigation
Highway 417 Overpass Structures at Booth Street
Ottawa, Ontario

Project No.	1655214 / 1120
Drawn:	KS
Date:	2019-05-03
Checked:	KCP
Review:	FJH

Figure A1

CH 17B-01 (Wet)
Core Box 1 of 1

Elevation 65.75 m Top Footing



Elevation 64.00 m EOH



Foundation Investigation
Highway 417 Overpass Structures at Booth Street
Ottawa, Ontario

Project No.	1655214 / 1120
Drawn:	KS
Date:	2019-05-03
Checked:	KCP
Review:	FJH

Figure A2

CH 17B-04 (Dry)
Core Box 1 of 1

Elevation 65.71 m Top Footing

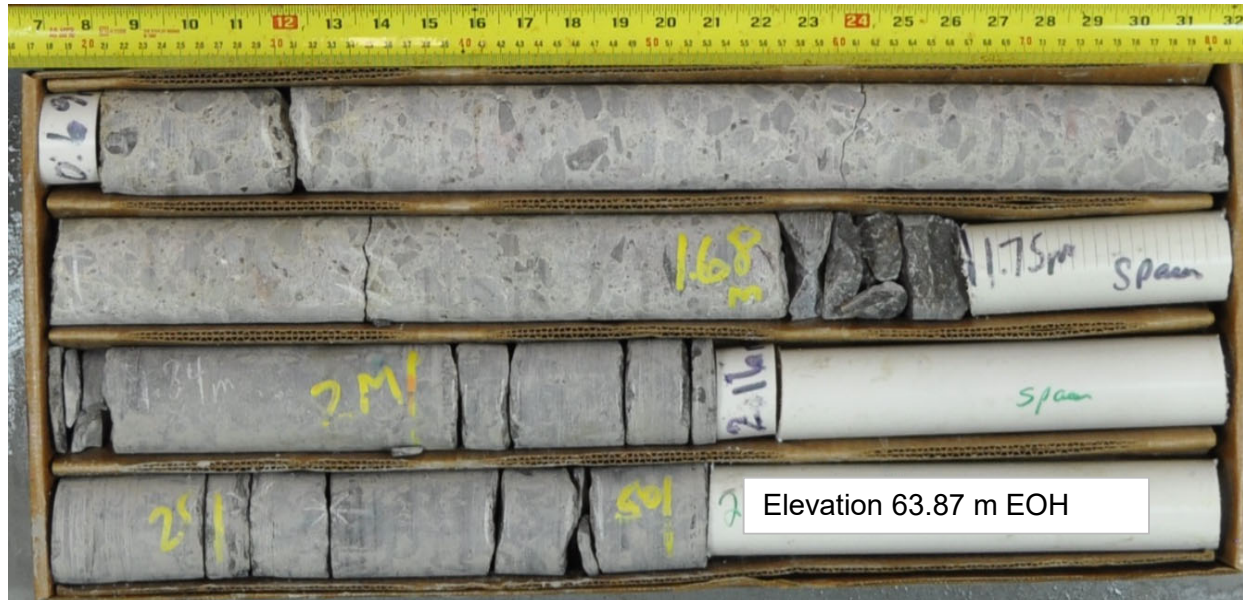

Foundation Investigation
Highway 417 Overpass Structures at Booth Street
Ottawa, Ontario

Project No.	1655214 / 1120
Drawn:	KS
Date:	2019-05-03
Checked:	KCP
Review:	FJH

Figure A3

CH 17B-04 (Wet)
Core Box 1 of 1

Elevation 65.71 m Top Footing

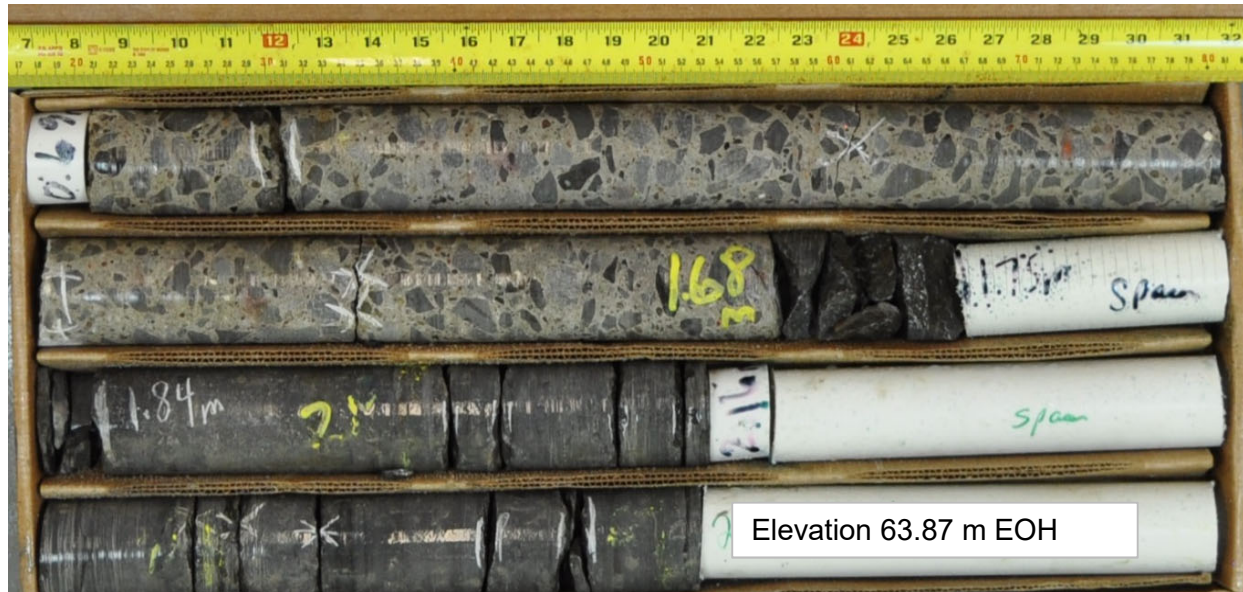

Foundation Investigation
Highway 417 Overpass Structures at Booth Street
Ottawa, Ontario

Project No.	1655214 / 1120
Drawn:	KS
Date:	2019-05-03
Checked:	KCP
Review:	FJH

Figure A4

CH 17-B08 (Dry)
Core Box 1 of 1

Elevation 65.87 m Top Footing



Elevation 64.32 m EOH



Foundation Investigation
Highway 417 Overpass Structures at Booth Street
Ottawa, Ontario

Project No.	1655214 / 1120
Drawn:	KS
Date:	2019-05-03
Checked:	KCP
Review:	FJH

Figure A5

CH 17-B08 (Wet)
Core Box 1 of 1

Elevation 65.86 m Top Footing

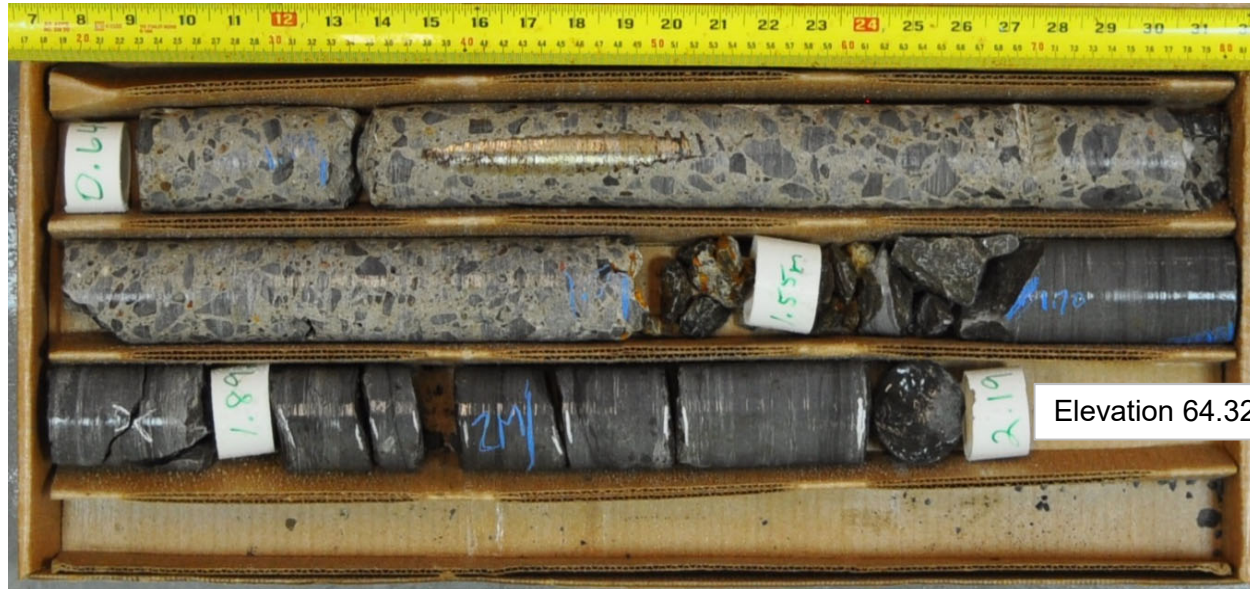

Elevation 64.32 m EOH



Foundation Investigation
Highway 417 Overpass Structures at Booth Street
Ottawa, Ontario

Project No.	1655214 / 1120
Drawn:	KS
Date:	2019-05-03
Checked:	KCP
Review:	FJH

Figure A6

CH 17-B12 (Dry)
Core Box 1 of 1

Elevation 65.88 m Top Footing

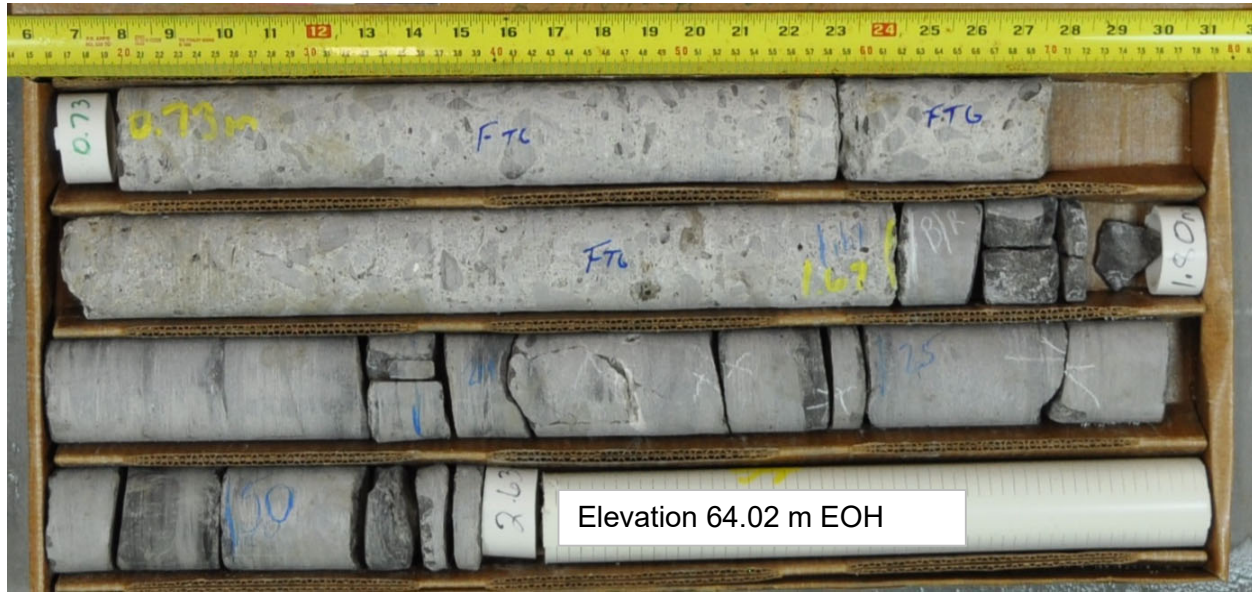

Elevation 64.02 m EOH



Foundation Investigation
Highway 417 Overpass Structures at Booth Street
Ottawa, Ontario

Project No.	1655214 / 1120
Drawn:	KS
Date:	2019-05-03
Checked:	KCP
Review:	FJH

Figure A7

CH 17-B12 (Wet)
Core Box 1 of 1

Elevation 65.88 m Top Footing

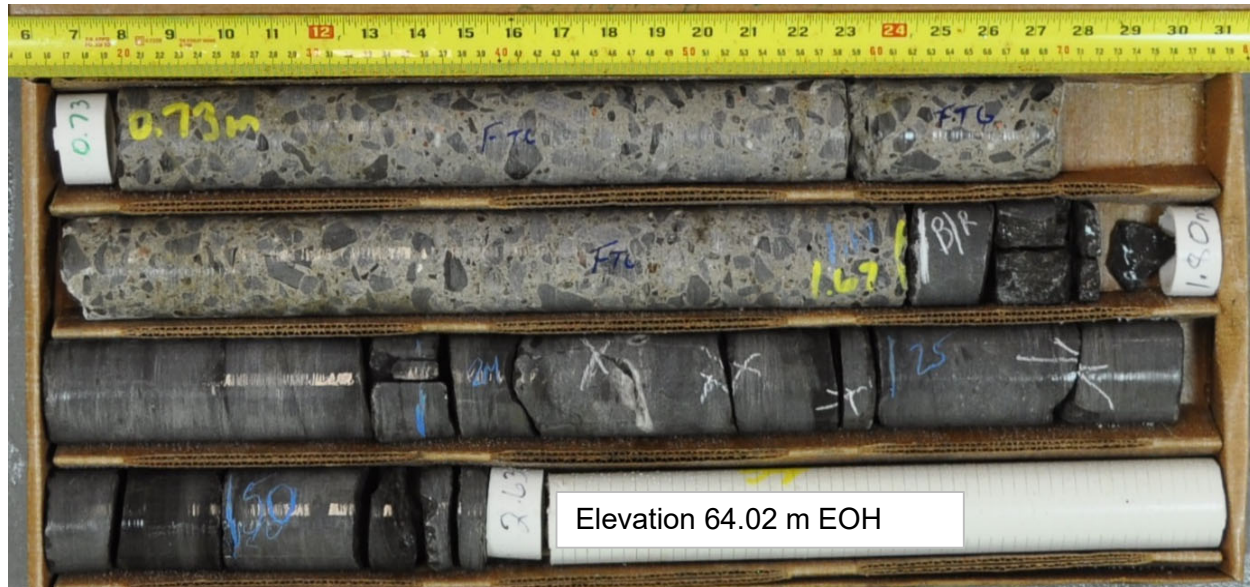

Foundation Investigation
Highway 417 Overpass Structures at Booth Street
Ottawa, Ontario

Project No.	1655214 / 1120
Drawn:	KS
Date:	2019-05-03
Checked:	KCP
Review:	FJH

Figure A8

CH 17-B13 (Dry)
Core Box 1 of 1

Elevation 65.87 m Top Footing

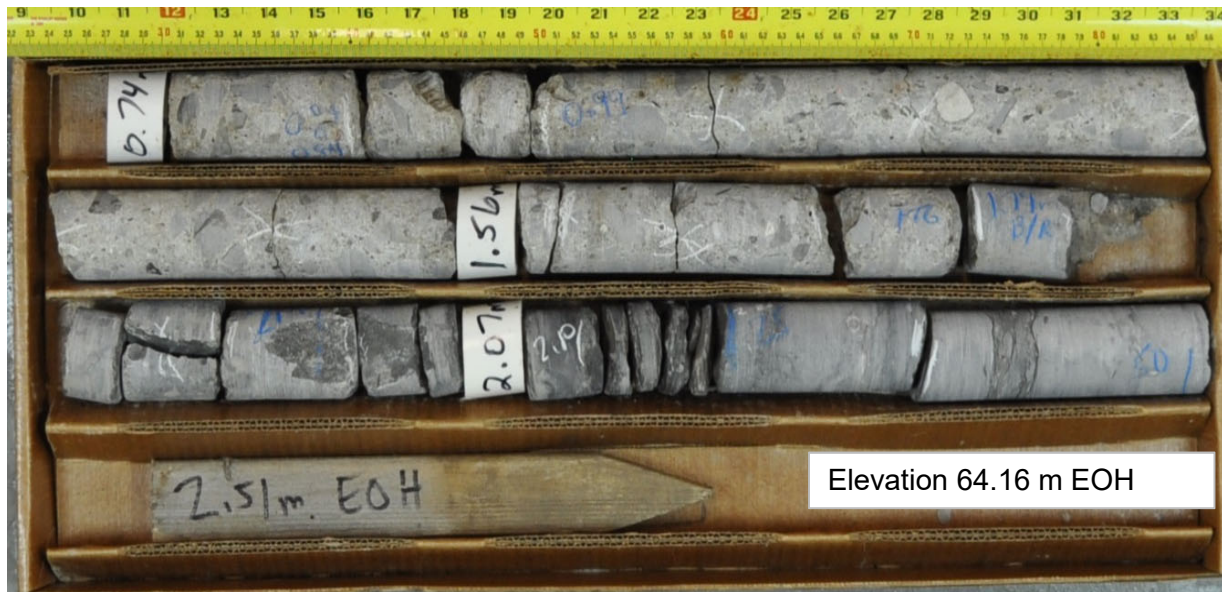

Elevation 64.16 m EOH



Foundation Investigation
Highway 417 Overpass Structures at Booth Street
Ottawa, Ontario

Project No.	1655214 / 1120
Drawn:	KS
Date:	2019-05-03
Checked:	KCP
Review:	FJH

Figure A9

CH 17-B13 (Wet)
Core Box 1 of 1

Elevation 65.87 m Top Footing

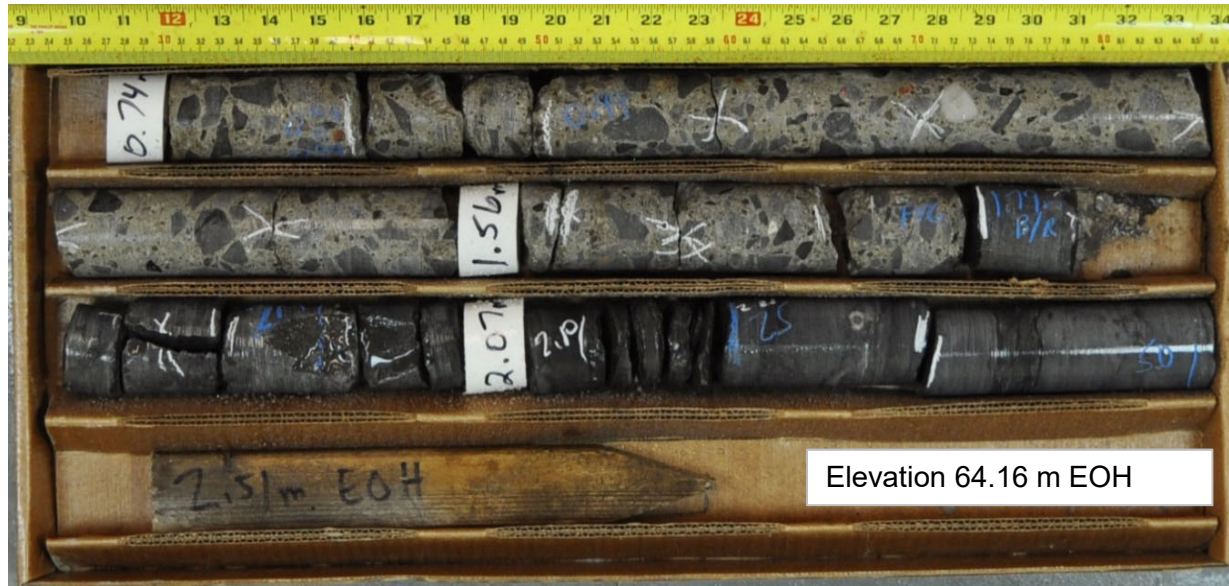

Foundation Investigation
Highway 417 Overpass Structures at Booth Street
Ottawa, Ontario

Project No.	1655214 / 1120
Drawn:	KS
Date:	2019-05-03
Checked:	KCP
Review:	FJH

Figure A10

CH 17-B16 (Dry)
Core Box 1 of 1

Elevation 65.84 m Top Footing



Elevation 64.33 m EOH



Foundation Investigation
Highway 417 Overpass Structures at Booth Street
Ottawa, Ontario

Project No.	1655214 / 1120
Drawn:	KS
Date:	2019-05-03
Checked:	KCP
Review:	FJH

Figure A11

CH 17-B16 (Wet)
Core Box 1 of 1

Elevation 65.84 m Top Footing



Foundation Investigation
Highway 417 Overpass Structures at Booth Street
Ottawa, Ontario

Project No.	1655214 / 1120
Drawn:	KS
Date:	2019-05-03
Checked:	KCP
Review:	FJH

Figure A12

CH 17-B20 (Dry)
Core Box 1 of 1

Elevation 65.72 m Top Footing

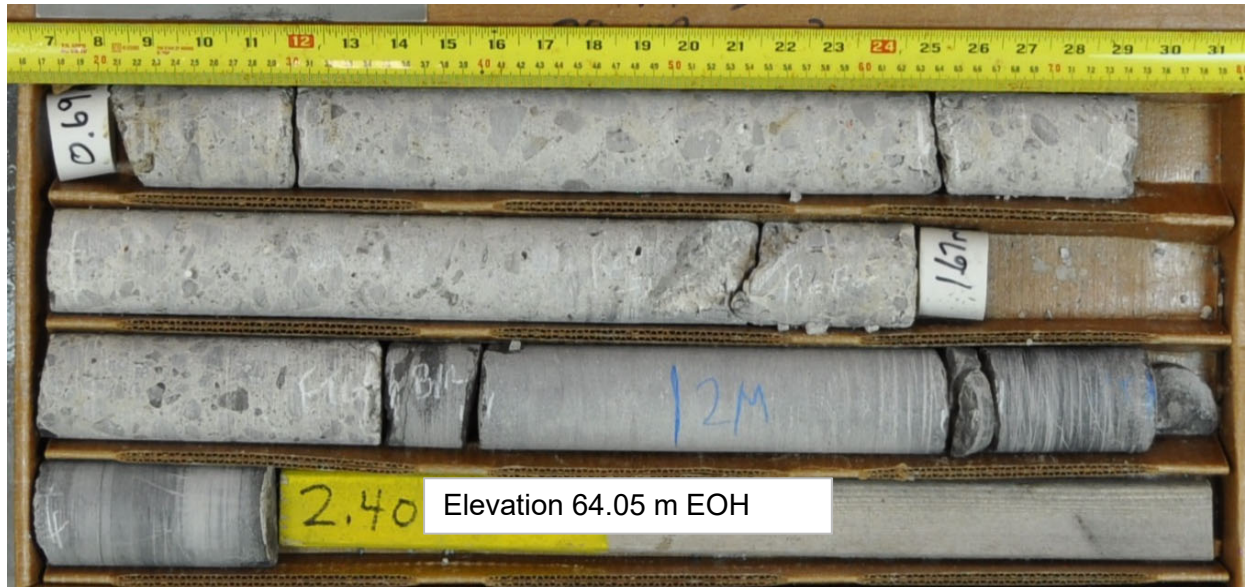

Foundation Investigation
Highway 417 Overpass Structures at Booth Street
Ottawa, Ontario

Project No.	1655214 / 1120
Drawn:	KS
Date:	2019-05-03
Checked:	KCP
Review:	FJH

Figure A13

CH 17-B20 (Wet)
Core Box 1 of 1

Elevation 65.72 m Top Footing



Foundation Investigation
Highway 417 Overpass Structures at Booth Street
Ottawa, Ontario

Project No.	1655214 / 1120
Drawn:	KS
Date:	2019-05-03
Checked:	KCP
Review:	FJH

Figure A14

CH 17-B24 (Dry)
Core Box 1 of 1

Elevation 65.73 m Top Footing



Elevation 64.14 m
EOH



Foundation Investigation
Highway 417 Overpass Structures at Booth Street
Ottawa, Ontario

Project No.	1655214 / 1120
Drawn:	KS
Date:	2019-05-03
Checked:	KCP
Review:	FJH

Figure A15

CH 17-B24 (Wet)
Core Box 1 of 1

Elevation 65.73 m Top Footing

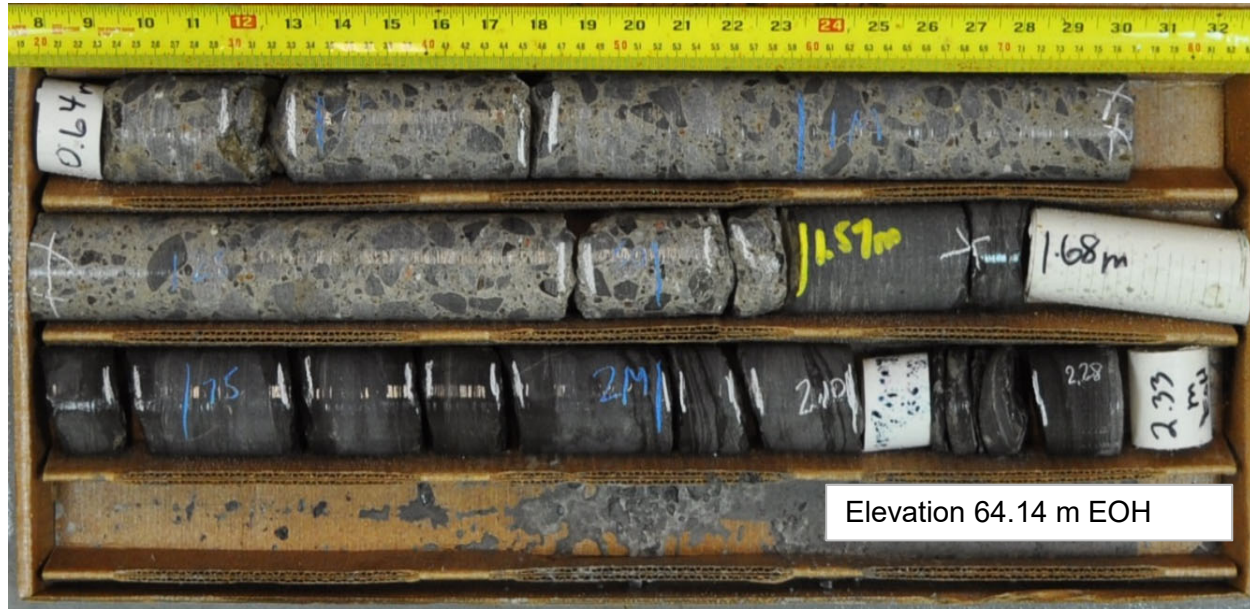

Foundation Investigation
Highway 417 Overpass Structures at Booth Street
Ottawa, Ontario

Project No.	1655214 / 1120
Drawn:	KS
Date:	2019-05-03
Checked:	KCP
Review:	FJH

Figure A16

BH 17-121 (Dry)
Core Box 1 and 2 of 2

Elevation 65.72 m Top of Bedrock

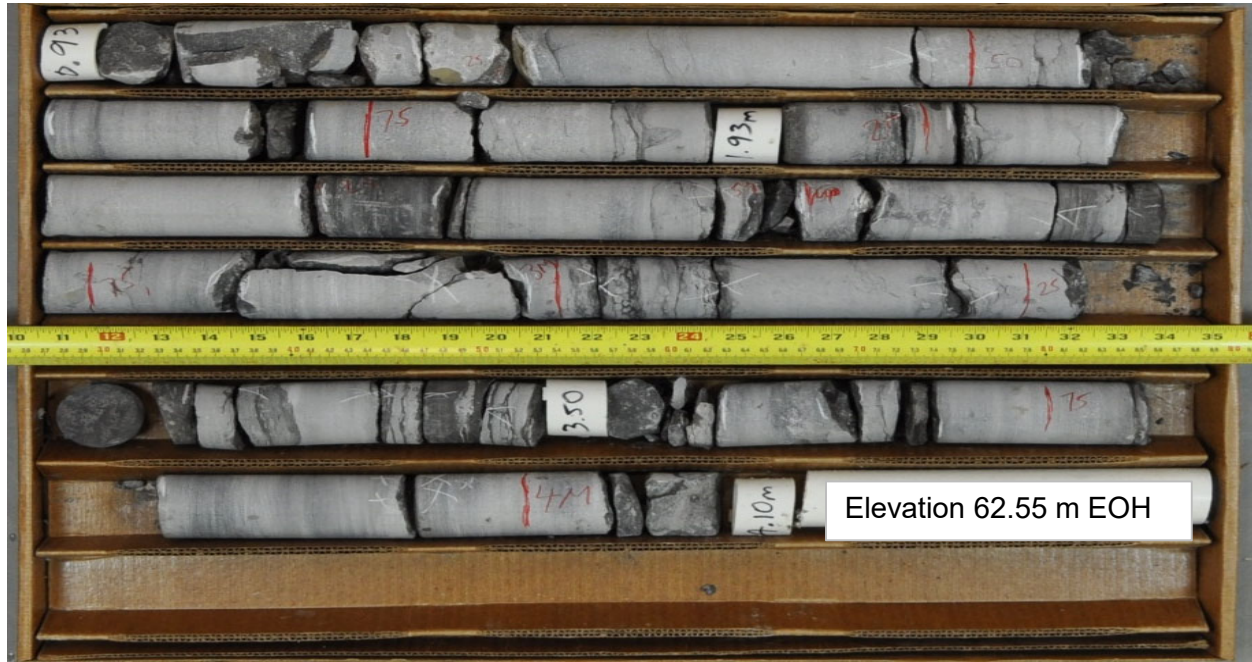

Foundation Investigation
Highway 417 Overpass Structures at Booth Street
Ottawa, Ontario

Project No.	1655214 / 1120
Drawn:	KS
Date:	2019-05-03
Checked:	KCP
Review:	FJH

Figure A17

**BH 17-121 (Wet)
Core Box 1 and 2 of 2**

Elevation 65.72 m Top of Bedrock

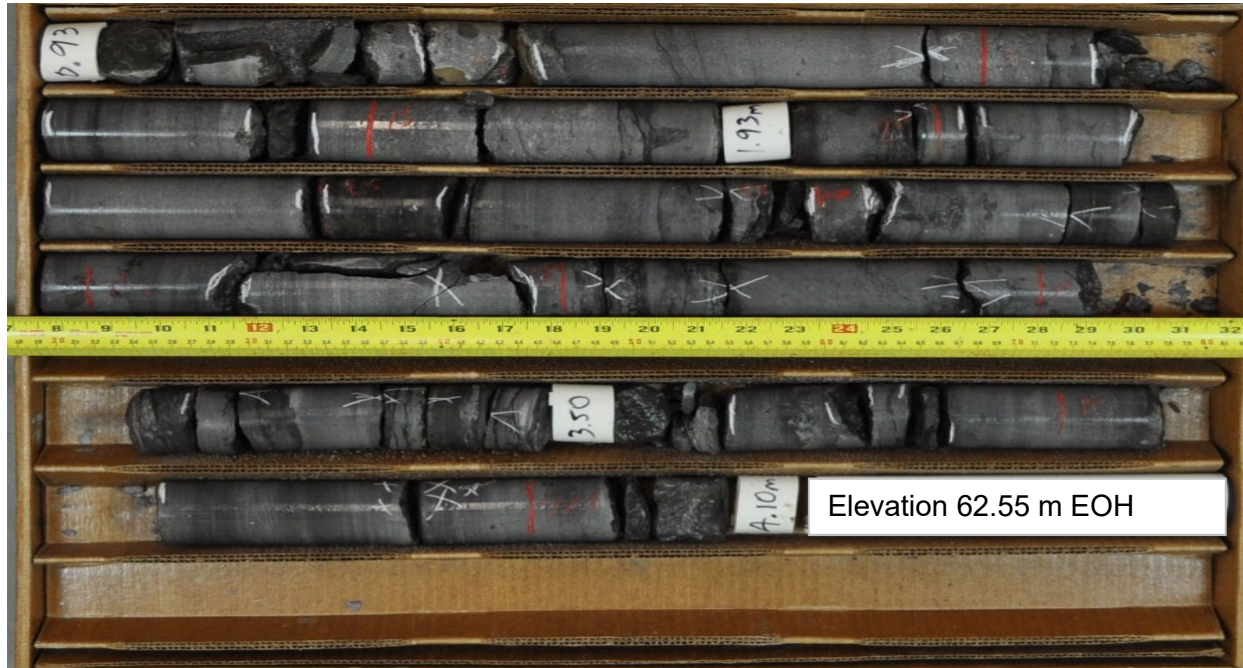

Elevation 62.55 m EOH



Foundation Investigation
Highway 417 Overpass Structures at Booth Street
Ottawa, Ontario

Project No.	1655214 / 1120
Drawn:	KS
Date:	2019-05-03
Checked:	KCP
Review:	FJH

Figure A18

BH 17-122 (Dry)
Core Box 1 and 2 of 2

Elevation 65.72 m Top of Bedrock

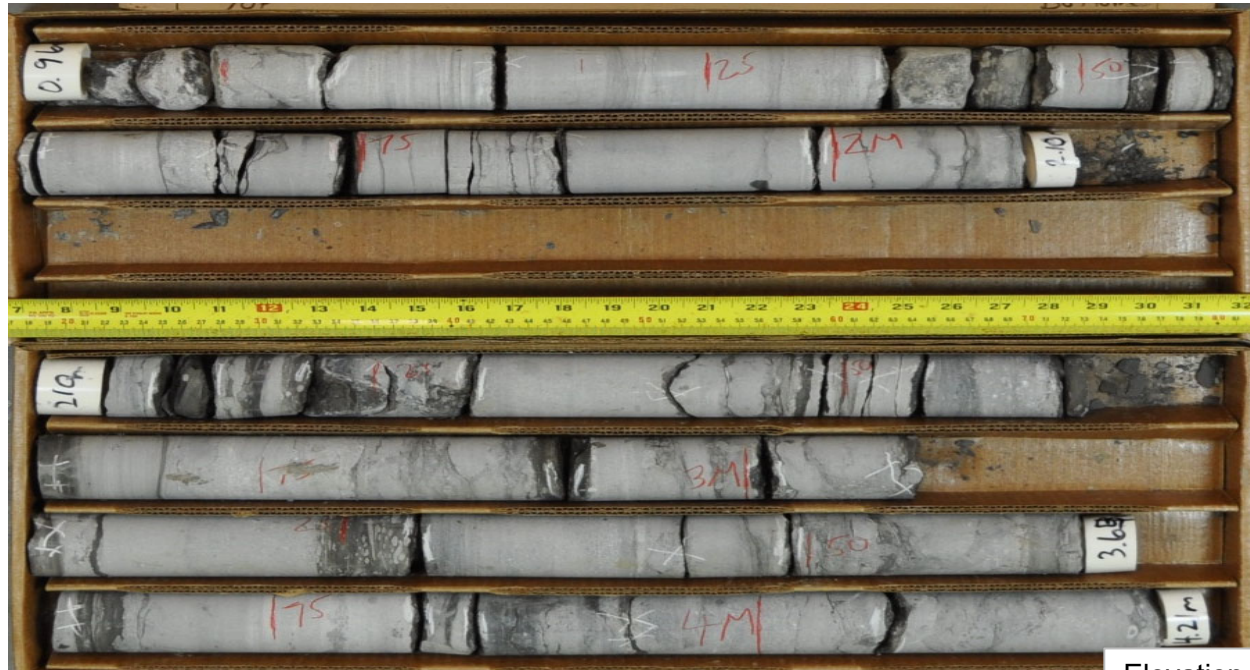

Elevation 62.47 m EOH



Foundation Investigation
Highway 417 Overpass Structures at Booth Street
Ottawa, Ontario

Project No.	1655214 / 1120
Drawn:	KS
Date:	2019-05-03
Checked:	KCP
Review:	FJH

Figure A19

BH 17-122 (Wet)
Core Box 1 and 2 of 2

Elevation 65.72 m Top of Bedrock

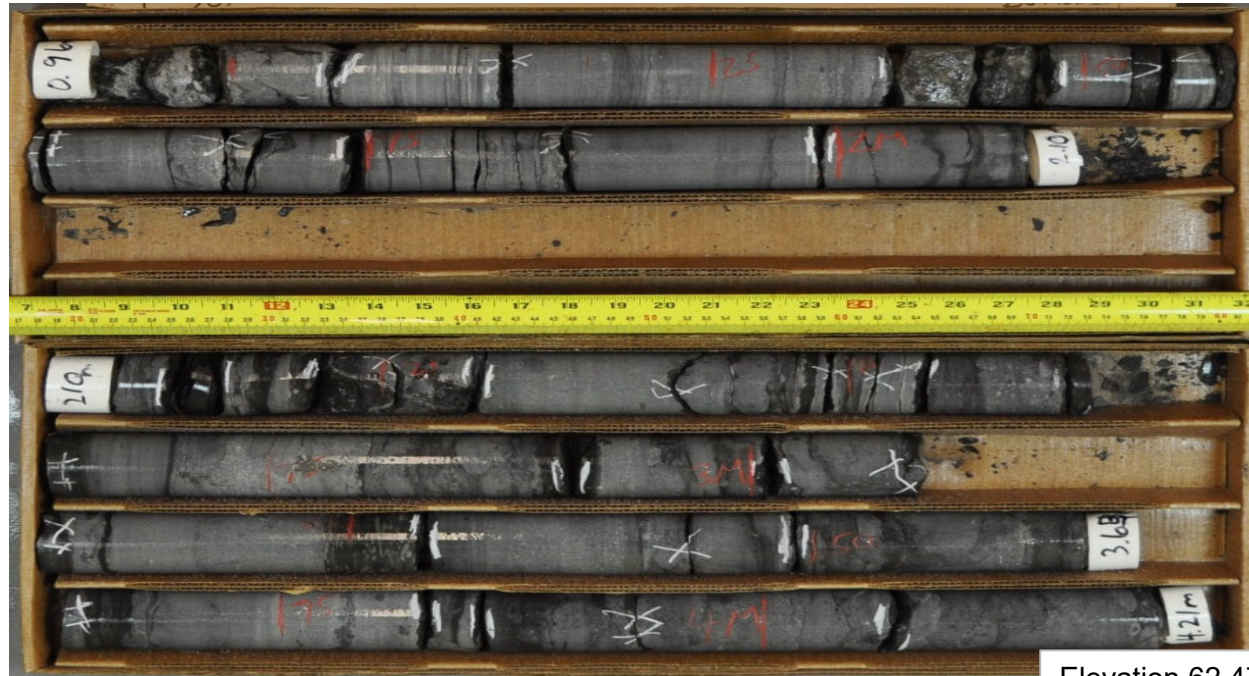

Elevation 62.47 m EOH



Foundation Investigation
Highway 417 Overpass Structures at Booth Street
Ottawa, Ontario

Project No.	1655214 / 1120
Drawn:	KS
Date:	2019-05-03
Checked:	KCP
Review:	FJH

Figure A20

BH 17-123 (Dry)
Core Box 1 and 2 of 2

Elevation 65.19 m Top of Bedrock

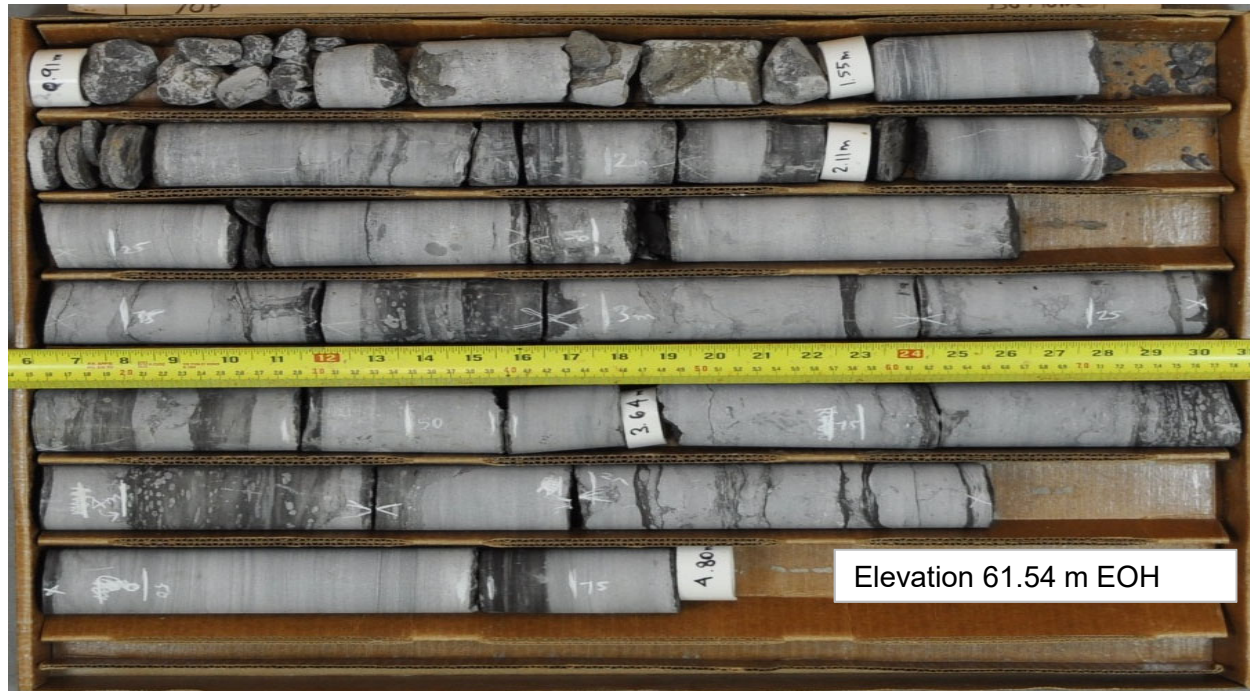

Elevation 61.54 m EOH



Foundation Investigation
Highway 417 Overpass Structures at Booth Street
Ottawa, Ontario

Project No.	1655214 / 1120
Drawn:	KS
Date:	2019-05-03
Checked:	KCP
Review:	FJH

Figure A21

**BH 17-123 (Wet)
Core Box 1 and 2 of 2**

Elevation 65.19 m Top of Bedrock

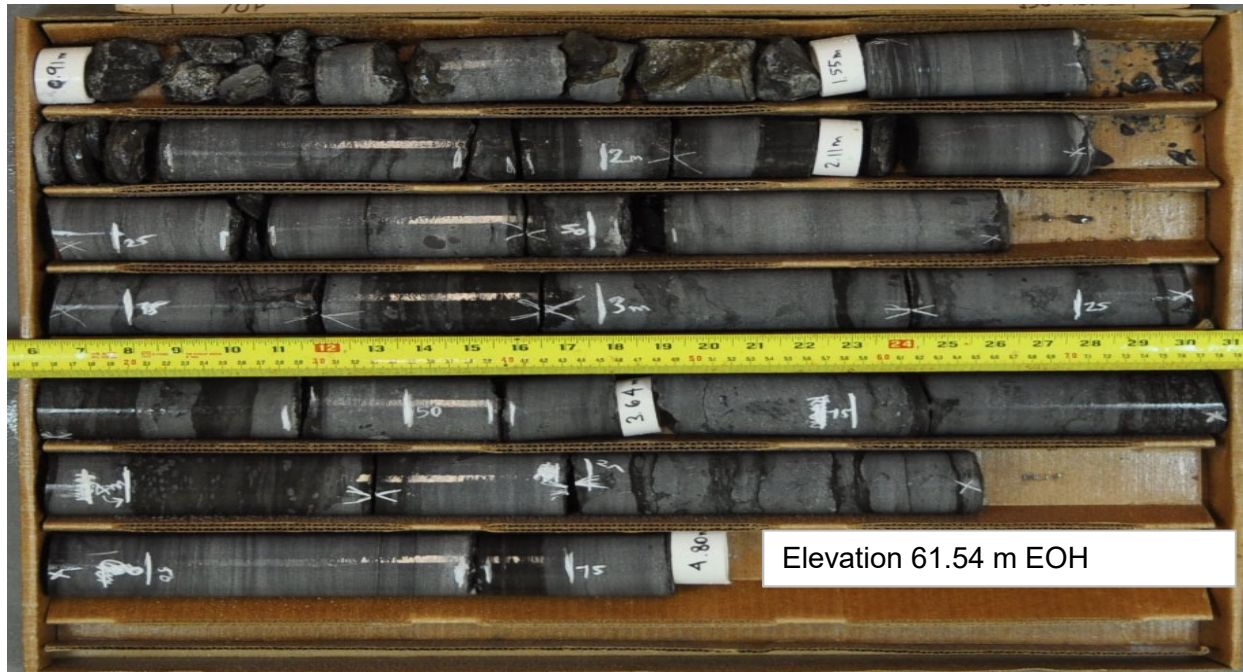

Elevation 61.54 m EOH



Foundation Investigation
Highway 417 Overpass Structures at Booth Street
Ottawa, Ontario

Project No.	1655214 / 1120
Drawn:	KS
Date:	2019-05-03
Checked:	KCP
Review:	FJH

Figure A22

BH 17-124 (Dry)
Core Box 1 and 2 of 2

Elevation 65.46 m Top of Bedrock



Elevation 61.91 m EOH



Foundation Investigation
Highway 417 Overpass Structures at Booth Street
Ottawa, Ontario

Project No.	1655214 / 1120
Drawn:	KS
Date:	2019-05-03
Checked:	KCP
Review:	FJH

Figure A23

**BH 17-124 (Wet)
Core Box 1 and 2 of 2**

Elevation 65.46 m Top of Bedrock



Elevation 61.91 m EOH



Foundation Investigation
Highway 417 Overpass Structures at Booth Street
Ottawa, Ontario

Project No.	1655214 / 1120
Drawn:	KS
Date:	2019-05-03
Checked:	KCP
Review:	FJH

Figure A24

CH 18-1201 (Dry)
Core Box 1 of 1

Elevation 65.40 m Top of Footing

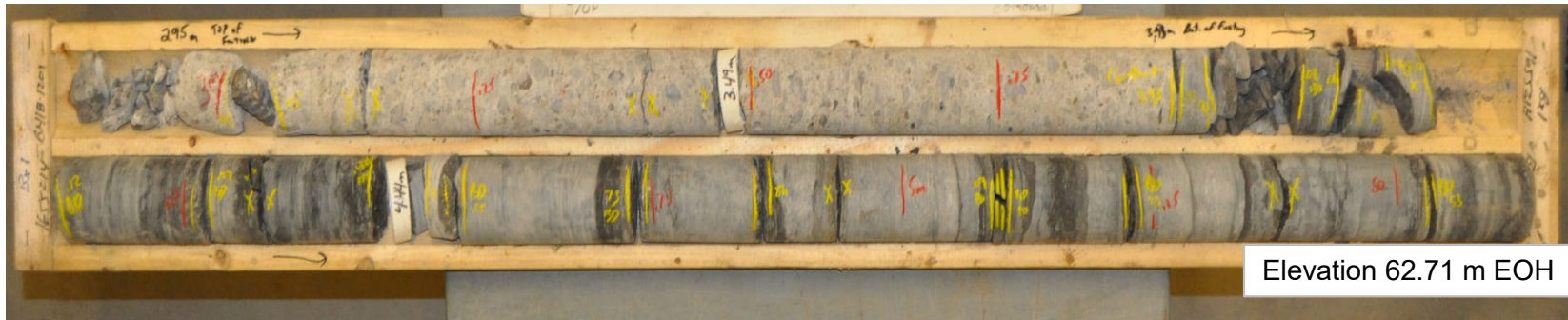

Elevation 62.71 m EOH



Foundation Investigation
Highway 417 Overpass Structures at Booth Street
Ottawa, Ontario

Project No.	1655214 / 1120
Drawn:	KS
Date:	2019-05-03
Checked:	KCP
Review:	FJH

Figure A25

CH 18-1201 (Wet)
Core Box 1 of 1

Elevation 65.40 m Top of Footing

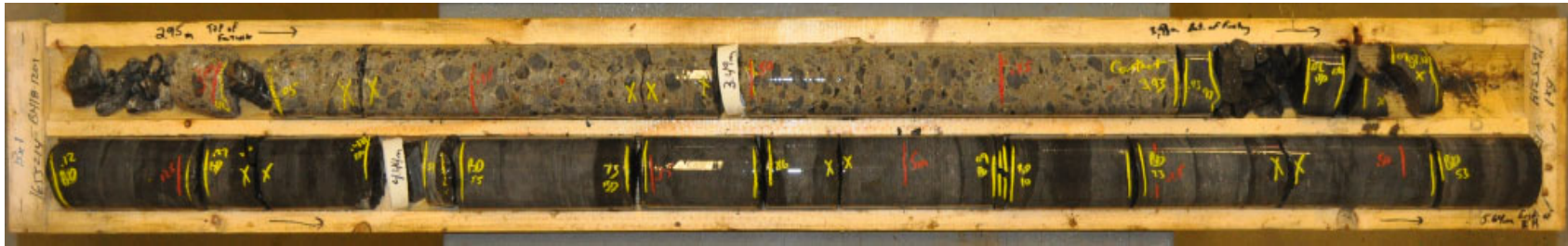

Elevation 62.71 m EOH



Foundation Investigation
Highway 417 Overpass Structures at Booth Street
Ottawa, Ontario

Project No.	1655214 / 1120
Drawn:	KS
Date:	2019-05-03
Checked:	KCP
Review:	FJH

Figure A26

CH 18-1202 (Dry)
Core Box 1 and 2 of 2

Elevation 66.73 m Top of Bedrock



Elevation 63.85 m EOH



Foundation Investigation
Highway 417 Overpass Structures at Booth Street
Ottawa, Ontario

Project No.	1655214 / 1120
Drawn:	KS
Date:	2019-05-03
Checked:	KCP
Review:	FJH

Figure A27

CH 18-1202 (Wet)
Core Box 1 and 2 of 2

Elevation 66.73 m Top of Footing

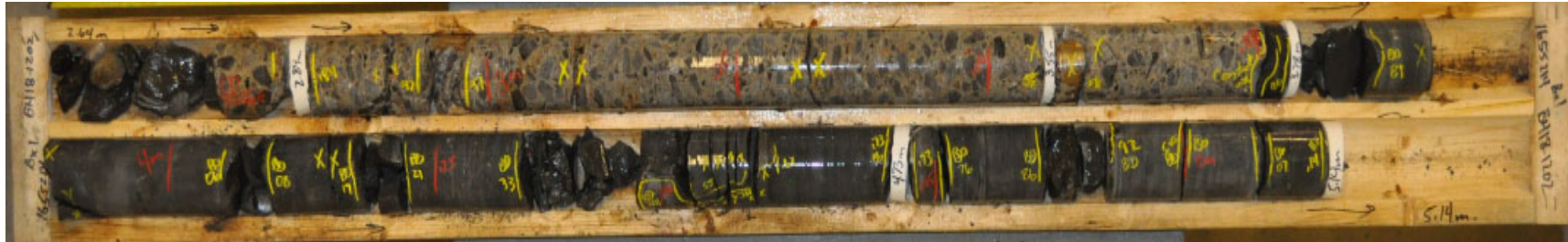

Elevation 63.85 m EOH



Foundation Investigation
Highway 417 Overpass Structures at Booth Street
Ottawa, Ontario

Project No.	165214 / 1120
Drawn:	KS
Date:	2019-05-03
Checked:	KCP
Review:	FJH

Figure A27

CH 18-1203 (Dry)
Core Box 1 of 1

Elevation 66.10 m Top of Footing

Boulder above Footing



Elevation 63.20 m EOH



Foundation Investigation
Highway 417 Overpass Structures at Booth Street
Ottawa, Ontario

Project No.	1655214 / 1120
Drawn:	KS
Date:	2019-05-03
Checked:	KCP
Review:	FJH

Figure A28

CH 18-1203 (Wet)
Core Box 1 of 1

Elevation 66.10 m Top of Footing

Boulder above Footing



Elevation 63.20 m EOH



Foundation Investigation
Highway 417 Overpass Structures at Booth Street
Ottawa, Ontario

Project No.	1655214 / 1120
Drawn:	KS
Date:	2019-05-03
Checked:	KCP
Review:	FJH

Figure A29

CH 18-1204 (Dry)
Core Box 1 of 1

Elevation 66.15 m Top of Footing

Boulder above footing

Elevation 63.43 m EOH

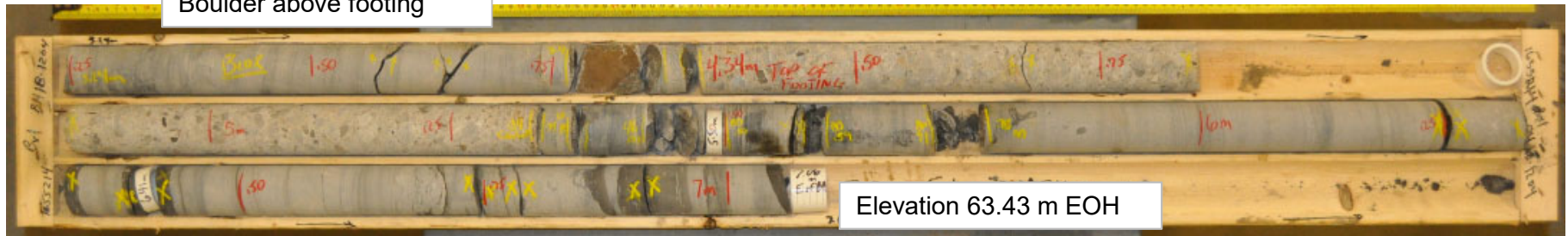

Foundation Investigation
Highway 417 Overpass Structures at Booth Street
Ottawa, Ontario

Project No.	1655214 / 1120
Drawn:	KS
Date:	2019-05-03
Checked:	KCP
Review:	FJH

Figure A30

CH 18-1204 (Wet)
Core Box 1 of 1

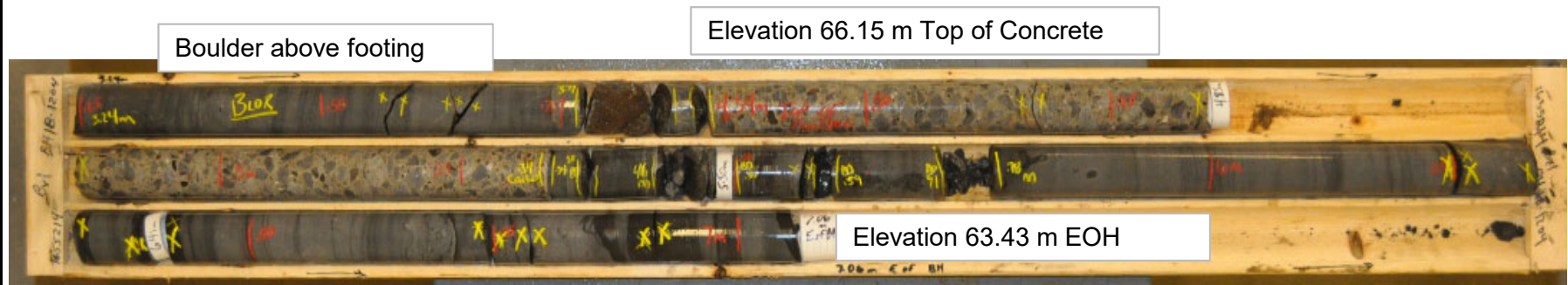

Foundation Investigation
Highway 417 Overpass Structures at Booth Street
Ottawa, Ontario

Project No.	1655214 / 1120
Drawn:	KS
Date:	2019-05-03
Checked:	KCP
Review:	FJH

Figure A31

**TABLE A1: Concrete Core Condition Assessment
Existing Concrete Footing - Booth Street**

Project No. 1655214 - 1120

2017-10-20 / 2019-05-30

CNM / KM

Booth Street**17-B01 : 0.61 - 1.54**

- Top surface ± intact.
- Wood (formwork?) along edge from 0.61 to 1.03m.
- Good condition, with only mechanical breaks to 1.47m.
- 1.47-1.54 : Washed-out muddy appearance. Loose aggregate pieces.
Likely poured in water.
- No bond to rock.

17-B04 : - 0.69 - 1.68

- Top surface ± intact.
- Good condition, with only mechanical breaks only.
- Partial bond to rock (rock surface broken up in coring).

17-B08 : 0.64 - 1.54

- Top surface ± intact.
- Drilled through 2 vertical re-bars (splice) and 2 horizontal bar.
- Concrete paste in good condition, but many voids present, including at aggregate interfaces; Likely insufficiently vibrated during placement.
- Mechanical breaks only.
- 1.53-1.55 : Heavily voided at rock interface; Voids heavily rust-stained.
No bond to rock; rock surface broken up in coring.

17-B12 : - 0.73 - 1.67

- Top surface broken up.
- Open cold joint at 1.23m with signs of dirt between lifts.
- Otherwise good condition, with only mechanical breaks only.
- Formed to rock surface at bottom, but not bonded (some of shaley rock surface lost in coring).

17-B13 : - 0.74 - 1.79

- Top surface ± intact.
- Small diameter core; much mechanical breakage.
- Otherwise good condition.
- No bond to rock. Bottom surface missing/lost in coring.
Lower 1cm shows signs of being placed in water.

17-B16 : - 0.69 - 1.79

- Top surface ± intact.
- Possible cold joint at 1.33m, but too much drilling damage (spun) to confirm.
- Otherwise good condition, with only mechanical breaks only.
- Formed to rock surface at bottom, but not bonded.

17-B20 : - 0.69 - 1.85

- Top surface ± intact, but very rough.
- Cold joint at 1.67m.
- Otherwise good condition, with only mechanical breaks only.
- Shaley rock surface lost in coring. Bottom of concrete partially formed to rock.



- 17-B24:** - 0.64 - 1.57
- Top surface broken up, missing.
- 0.70-0.73 : Heavily voided break.
- Otherwise good condition, with only mechanical breaks only.
- Formed to rock surface at bottom, but not bonded.
- 18-1201** 2.95 to 3.93
Top of surface of concrete broken up, possibly due to coring (approx 3" of cover)
Rebar at 3.03, 32 m of Ø bar
Well consolidated, mechanical breaks only
Good bond to rock, broken during coring
- 18-1202** 2.77 to 3.75
Plastic at surface
Good condition, mechanical breaks
Core broken at shallow depth/Top of surface broken
Core broken at 3.55 due to rebar
Well formed but unbonded to rock
- 18-1203** 2.60 to 3.67
Rebar at 2.74 - 2.75 m (~ 140 mm cover)
Broken at 2.73 to 2.78 m (due to rebar and spinning during coring)
Occasional air entrainment
Well consolidated, mechanical breaks only
Good bond to rock
- 18-1204** 4.34 to 5.34
Well consolidated, occasional air void entrainment
Good condition, mechanical breaks only
Unbonded to rock, presence of "fibrous", "paperlike" material between the concrete and rock

Laboratory Test Results, Current Investigation

Figure B1 – Grain Size Distribution Test Results – Sand to Silty Sand - Fill

Figure B2 – Grain Size Distribution Test Results – Sand - Fill

Figure B3 – Grain Size Distribution Test Results – Sandy Clayey Silt - Fill Gravel and Sand - Fill

Figure B4 – Grain Size Distribution Test Results – Gravelly Silty Sand Trace Clay - Till

Figure B5 – Grain Size Distribution Test Results – Sand, Gravelly Sand, and Sand and Gravel - Fill

Figure B6 – Grain Size Distribution Test Results – Sand and Gravel - Fill

Figure B7 – Summary of Laboratory Compressive Strength Unconfined Compression Tests

SAND TO SILTY SAND (FILL)

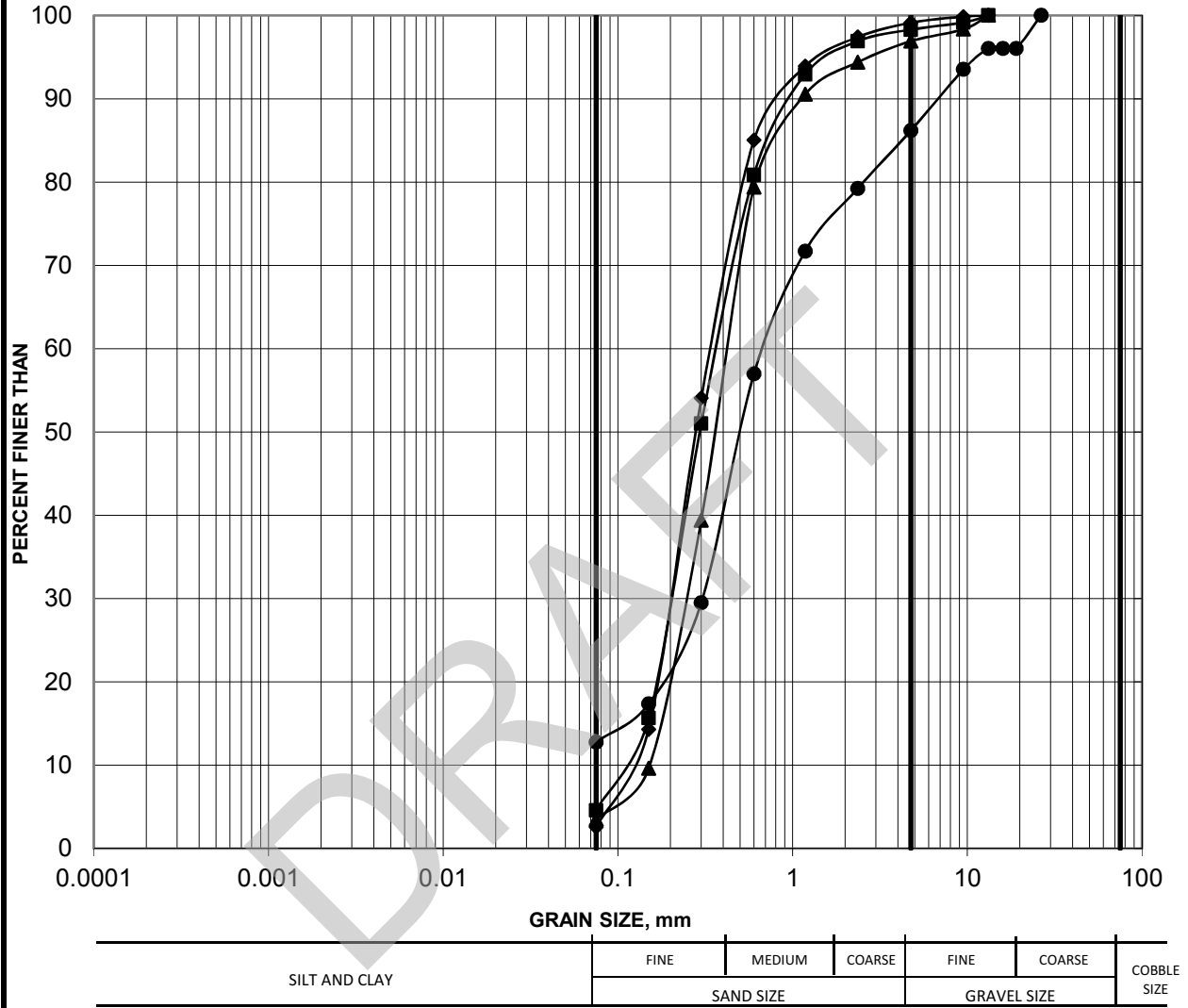

Borehole	Sample	Depth (m)
18-1201	1	0.00-0.61
18-1203	2	0.61-1.22
18-1204	3	2.59-3.20
18-1206	5B	3.81-4.37

GRAIN SIZE DISTRIBUTION

FIGURE B2

SAND (FILL)

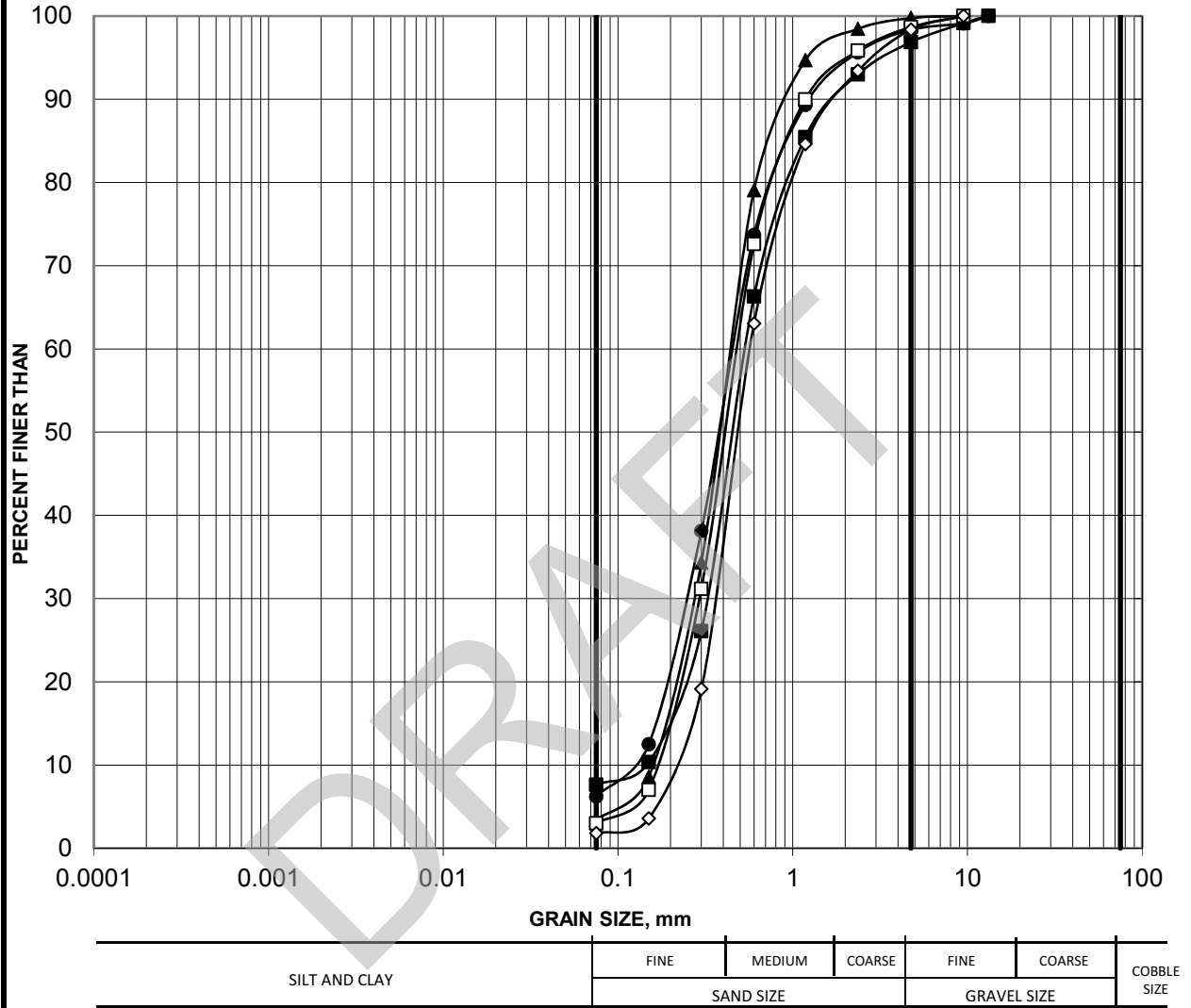

Borehole	Sample	Depth (m)
18-1205	7	4.57-5.18
18-1206	7	5.34-5.95
18-1207	4	2.28-2.89
18-1207	7	4.57-5.18
18-1208	7	4.57-5.18

SANDY CLAYEY SILT (FILL)

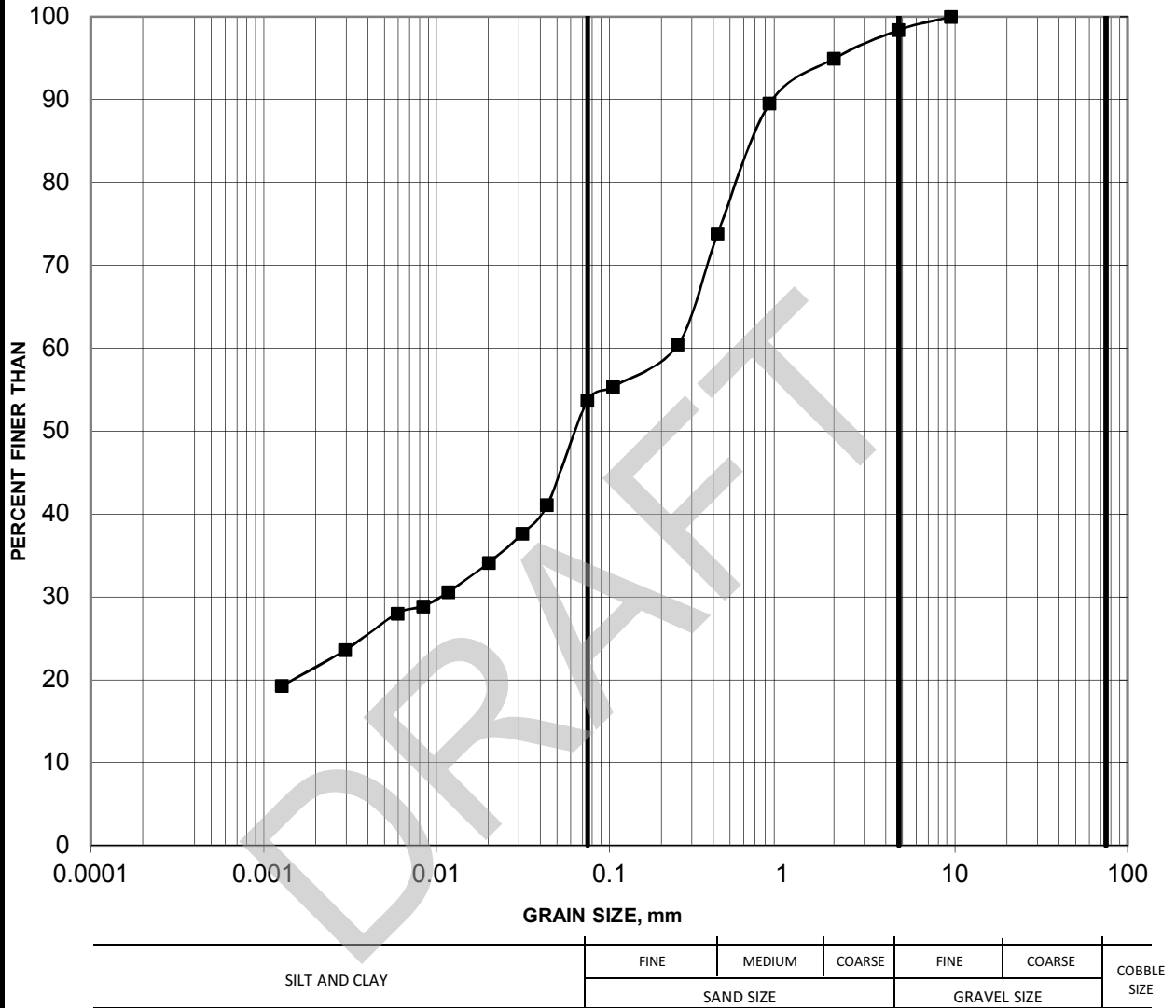

Borehole	Sample	Depth (m)
—■— 18-1208	8	5.33-5.94

GRAVELLY SILTY SAND TRACE CLAY (TILL)

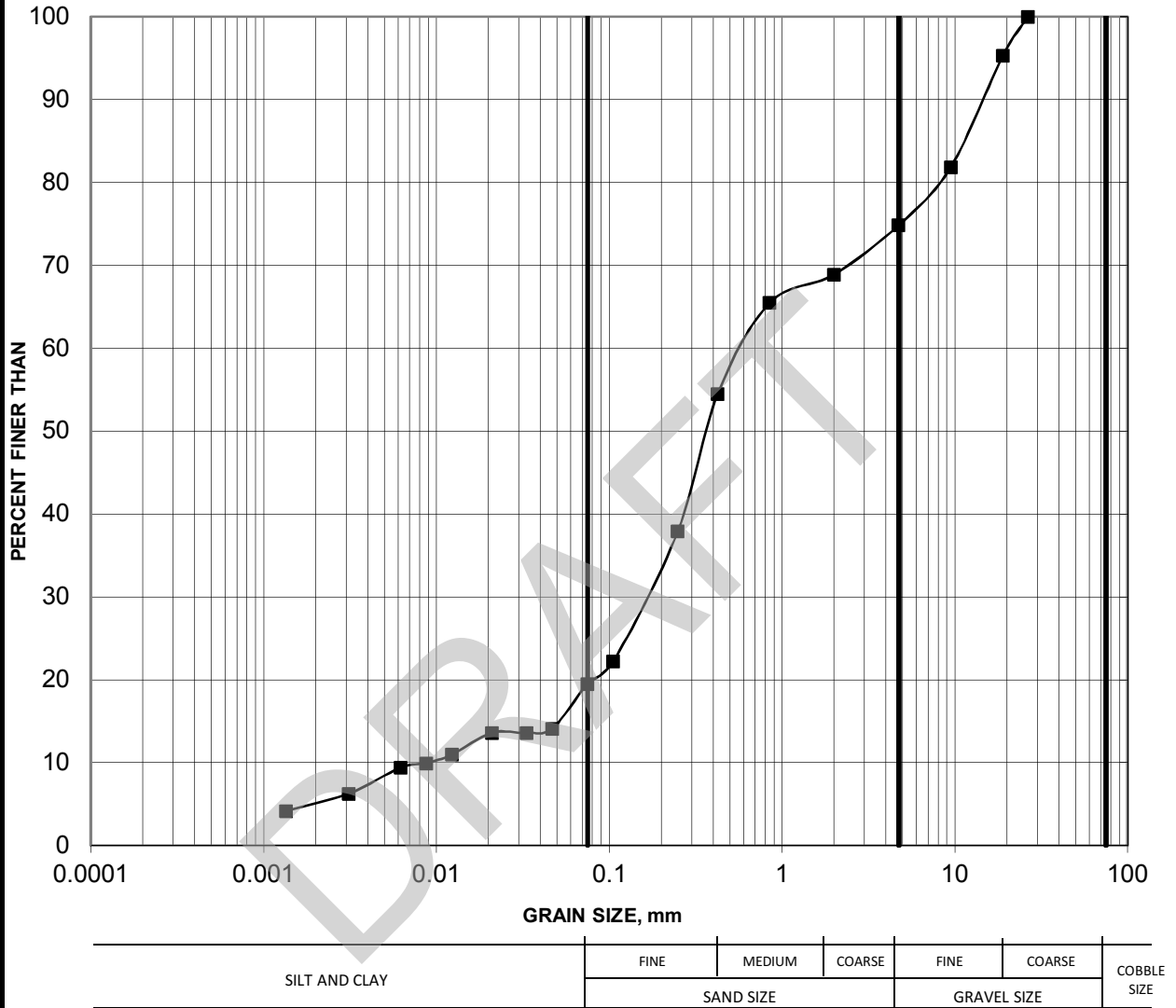

Borehole	Sample	Depth (m)
—■— 18-1207	9	6.09-6.70

SAND, GRAVELLY SAND, AND SAND AND GRAVEL (FILL)

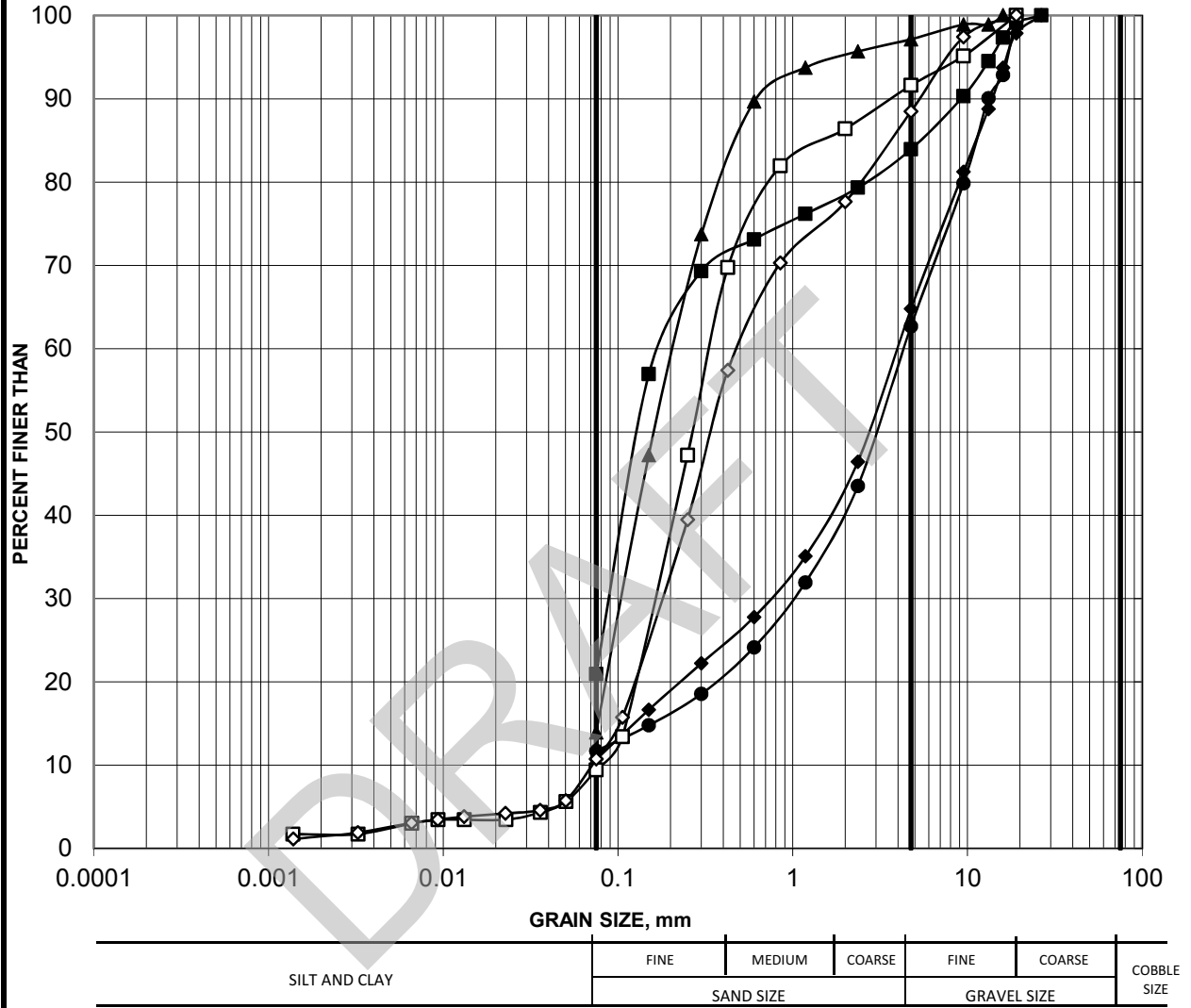

Borehole	Sample	Depth (m)
17-B05	1	0.31-0.69
17-B12	1	0.17-0.30
17-B13	2	0.22-0.60
17-B19	1	0.17-0.30
17-121	1	0.27-0.88
17-124	1	0.30-0.71

GRAVEL AND SAND (FILL)

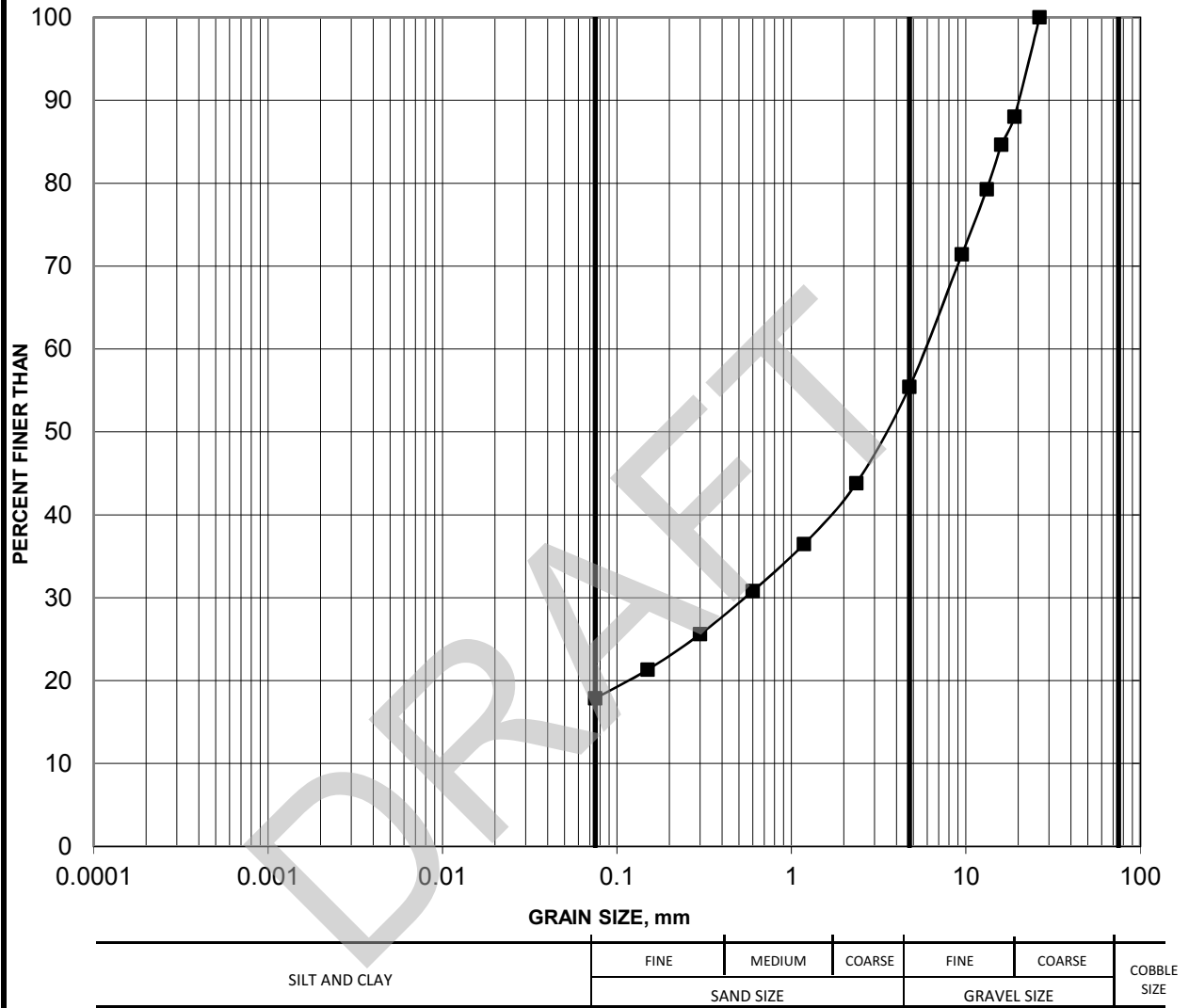

Borehole	Sample	Depth (m)
■ 18-1212	2	0.76-1.37

SUMMARY OF LABORATORY COMPRESSIVE STRENGTH
UNCONFINED COMPRESSION TESTS

FIGURE B7

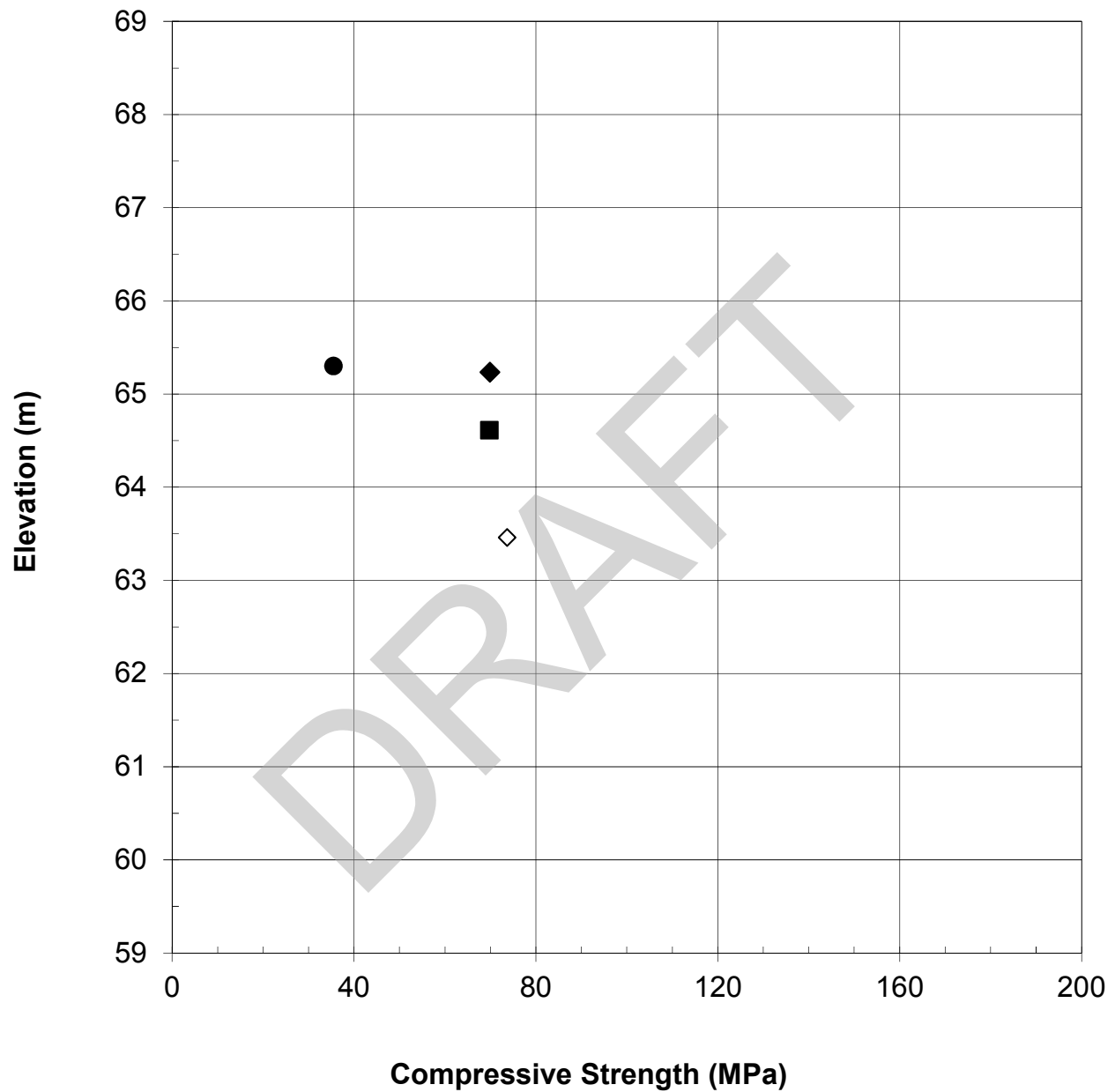

APPENDIX C

Previous Investigations, GEOCREG 31G05-030 (1959)
Soil Profile & Laboratory Tests Sheets
No. 1 to 7
Test Boring Plan

JOHN D. PATERSON
CONSULTING ENGINEER
OTTAWA CANADA

SOIL PROFILE
&
LABORATORY TESTS

Location: Bridge No. 17 - Beeth Street,
The Queensway.

ELEVATION (Zero Depth): 218.7
Remarks: Test Borings

Sheet No.
3 of 7

Hole No.
3

Borings by: F.E. Johnston Drilling Co., Ltd. Date: Nov. 25, 1959.

BLOWS PER FOOT	SOIL DESCRIPTION	Samples Type No.	Unsat. Comp. Strength Ton/Sq. Ft.	Depth in Feet	ELEV.	MOISTURE CONTENT PER CENT.				
						30	40	50	60	70
0	Ground Surface			0	218.7					
1	Black Top Soil			1						
	Fill - Boulders & Clay			2	216.2					
				3	215.8					
	Bedrock Limestone with minor shale. One band 1 inch thick. Minor carbonate replacement and mineralization.	Core	96% Recovery	4						
		Core	97% Recovery	6						
				7						
				8						
				9	210					

Ground Water
Level 215'

(Rock)

Footing Elevation

JOHN D. PATERSON
CONSULTING ENGINEER
OTTAWA CANADA

SOIL PROFILE
&
LABORATORY TESTS

Location: Bridge No. 17 - Booth Street,
The Queensway.

ELEVATION (Zero Depth): 217.5
Remarks: Test Borings

Sheet No.
4 of 7

Hole No.
4.

Borings by: F. E. Johnston Drilling Co., Ltd. Date: Nov. 24, 1959.

BLOWS PER FOOT	SOIL DESCRIPTION	Samples Taken		Depth in Feet	ELEV.	MOISTURE CONTENT PER CENT.				
		Type	No.			Comp. Strength Ton/Sq. Ft.	30	40	50	60
	Ground Surface		0		0 - 217.5					
	Black Clayey Top Soil		1'		1 -					
	Fill Material (Clayey-Sand)		2' 6"		2 - 215.0					(Rock)
	Bedrock	Core			3 - 214.0					Ground Water Level 3' 6"
	Limestone to 7 feet followed by limestone interbedded with shale layers up to 2 inches thick. Minor carbonate and minor mineralization.				4 -					96% Recovery
					5 -					
					6 -					
					7 -					
					8 - 210.0					Footing Elevation
					9 -					
		Core			10 -					98% Recovery
					11 -					
					12 -					
					13 - 205.0					
			13' 1"		14 -					
					15 -					

JOHN D. PATERSON
CONSULTING ENGINEER
OTTAWA CANADA

SOIL PROFILE
&
LABORATORY TESTS

Location: Bridge No. 17 - Beeth Street,
The Queensway.

ELEVATION (Zero Depth): 219.3
Remarks: Test Borings

Sheet No.
7 of 7.

Hole No.
7.

Borings by: F.S. Johnston Drilling Co., Ltd. Date: Nov. 26, 1959.

BLOWS PER FOOT	SOIL DESCRIPTION	Samples		Unsat. Comp. Strength Ton/Sq Ft.	Depth in Feet	ELEV.	MOISTURE CONTENT PER CENT.							
		Type	No.				30	40	50	60	70			
	Ground Surface		0		0	219.3								
	Black Top Soil		1		1									
	Boulder Till		2 1/4"		2	217.0								
	Bedrock Limestones with thin layers of interbedded shale with decreasing shale content with depth. Minor carbonate replacement and very minor mineralization.	Core		100% Recovery	3									
		Core		99% Recovery	4	215.								
		Core		100% Recovery	5									
		Core		100% Recovery	6									
		Core		94% Recovery	7									
		Core		95% Recovery	8									
		Core		95% Recovery	9	210								
		Core		94% Recovery	10									
		Core		95% Recovery	11									
		Core		95% Recovery	12									
		Core		95% Recovery	13									
		Core		95% Recovery	14	205								
		Core		95% Recovery	15									
			14' 10 1/2"											

Footing Elevation

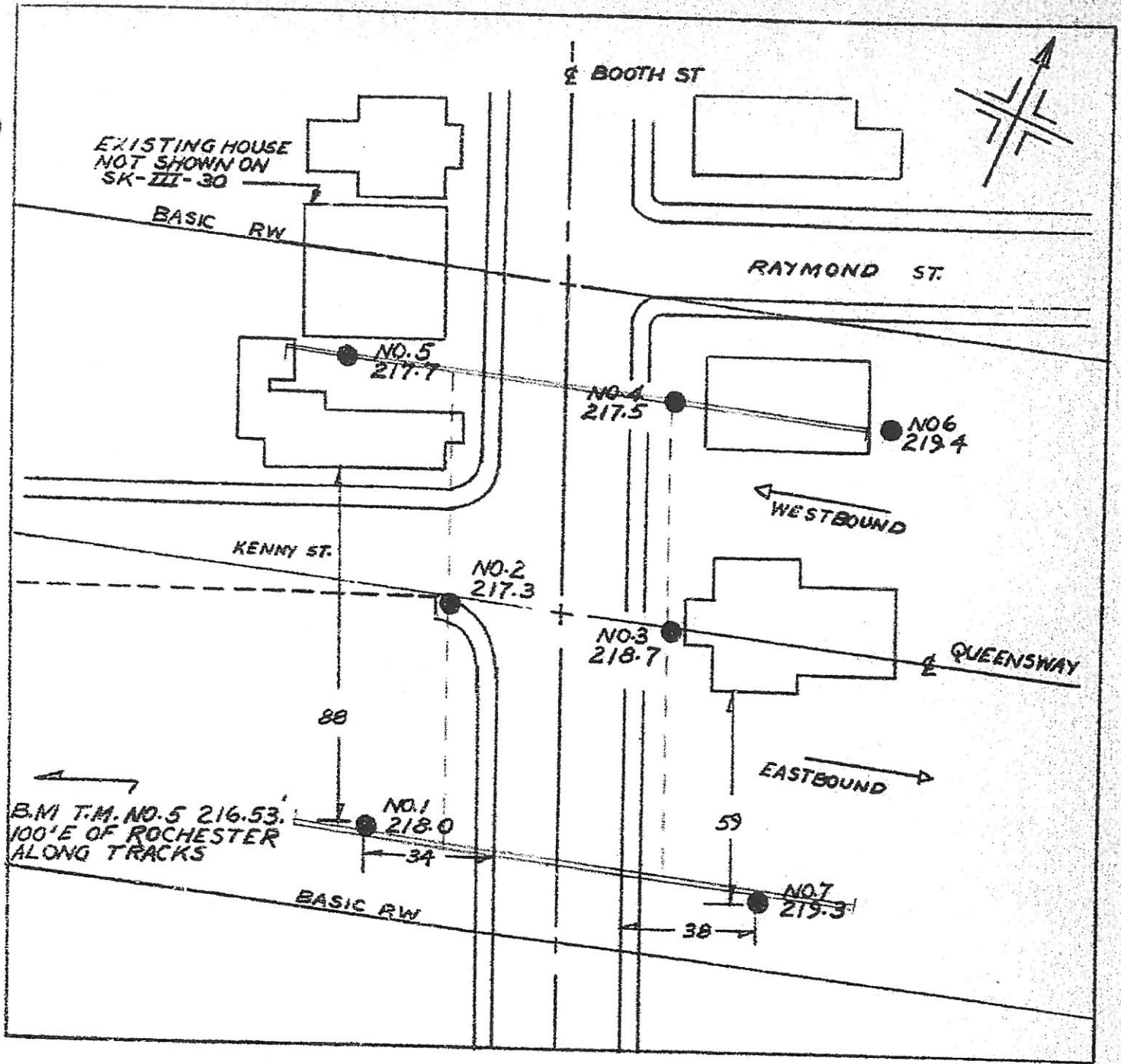

TEST BORING PLAN
 QUEENSWAY
 BRIDGE NO. 17 AT BOOTH ST.
 OTTAWA, ONT.

SCALE 1"=40'

NOV. 1959

JOB NO C-44-M

STAGE III

PLAN TAKEN FROM SK-III-30

APPENDIX D

Results of Chemical Analysis
Eurofins Environment Testing Report No. 1706532

Certificate of Analysis

Client: Golder Associates Ltd. (Ottawa)
 1931 Robertson Road
 Ottawa, ON
 K2H 5B7
 Attention: Ms. Susan Trickey
 PO#:
 Invoice to: Golder Associates Ltd. (Ottawa)

Report Number: 1706532
 Date Submitted: 2017-05-02
 Date Reported: 2017-05-09
 Project: 1655214.1120
 COC #: 817720

Lab I.D.	1290760
Sample Matrix	Soil
Sample Type	
Sampling Date	2017-04-26
Sample I.D.	17-122 SA1

Group	Analyte	MRL	Units	Guideline	
Agri. - Soil	pH	2.0			8.8
General Chemistry	Electrical Conductivity	0.05	mS/cm		0.63
	Resistivity	1	ohm-cm		1590
	SO4	0.01	%		<0.01
Subcontract	Cl	0.002	%		0.028

Guideline = * = Guideline Exceedence

All analysis completed in Ottawa, Ontario (unless otherwise indicated by ** which indicates analysis was completed in Mississauga, Ontario).
 Results relate only to the parameters tested on the samples submitted.
 Methods references and/or additional QA/QC information available on request.

MRL = Method Reporting Limit, AO = Aesthetic Objective, OG = Operational Guideline, MAC = Maximum Acceptable Concentration, IMAC = Interim Maximum Acceptable Concentration, STD = Standard, PWQO = Provincial Water Quality Guideline, IPWQO = Interim Provincial Water Quality Objective, TDR = Typical Desired Range

APPENDIX E

MASW Test Results and Report
Sites 3-56/1 and 3-56/2 Highway 417 Overpass at Rochester Street

DATE December 8, 2017

PROJECT No. 1655214/1500

TO Susan Trickey
Golder Associates Ltd.

FROM Stephane Sol
Christopher Phillips

EMAIL ssol@golder.com
cphillips@golder.com

CHBDC SEISMIC SITE CLASS TESTING RESULTS – HWY417 (ROCHESTER ST EXIT) OTTAWA, ONTARIO

This technical memorandum presents the results of one Multichannel Analysis of Surface Waves (MASW) test performed for the purpose of the Canadian Highway Bridge Design Code (CHBDC 2014) Seismic Site Classification for a site located near the HWY417 off ramp to Rochester Street just east of Preston Street in Ottawa, Ontario (Figure 1). The MASW line was located on a grassy area on north of the off ramp. The geophysical testing was performed by Golder personnel on October 18, 2017.

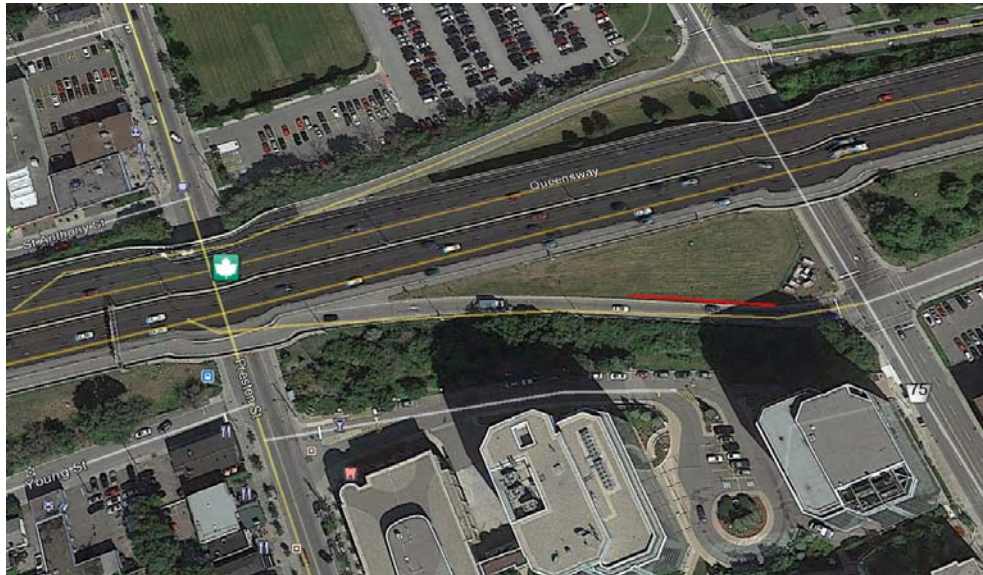

Figure 1: MASW Location Site Map (MASW Line in red)

Golder Associates Ltd.

6925 Century Avenue, Suite #100, Mississauga, Ontario, Canada L5N 7K2
Tel: +1 (905) 567 4444 Fax: +1 (905) 567 6561 www.golder.com

Golder Associates: Operations in Africa, Asia, Australasia, Europe, North America and South America

Golder, Golder Associates and the GA globe design are trademarks of Golder Associates Corporation.



Methodology

The MASW method measures variations in surface-wave velocity with increasing distance and wavelength and can be used to infer the rock/soil types, stratigraphy and soil conditions.

A typical MASW survey requires a seismic source, to generate surface waves, and a minimum of two geophone receivers, to measure the ground response at some distance from the source. Surface waves are a special type of seismic wave whose propagation is confined to the near surface medium.

The depth of penetration of a surface wave into a medium is directly proportional to its wavelength. In a non-homogeneous medium, surface waves are dispersive, i.e., each wavelength has a characteristic velocity owing to the subsurface heterogeneities within the depth interval that particular wavelength of surface wave propagates through. The relationship between surface-wave velocity and wavelength is used to obtain the shear-wave velocity and attenuation profile of the medium with increasing depth.

The seismic source used can be either active or passive, depending on the application and location of the survey. Examples of active sources include explosives, weight-drops, sledge hammer and vibrating pads. Examples of passive sources are road traffic, micro-tremors, and water-wave action (in near-shore environments).

The geophone receivers measure the wave-train associated with the surface wave travelling from a seismic source at different distances from the source.

The participation of surface waves with different wavelengths can be determined from the wave-train by transforming the wave-train results into the frequency domain. The surface-wave velocity profile with respect to wavelength (called the 'dispersion curve') is determined by the delay in wave propagation measured between the geophone receivers. The dispersion curve is then matched to a theoretical dispersion curve using an iterative forward-modelling procedure. The result is a shear-wave velocity profile of the tested medium with depth, which can be used to estimate the dynamic shear-modulus of the medium as a function of depth.

Field Work

The MASW field work was conducted on October 18, 2017, by personnel from the Golder Mississauga and Ottawa offices. For the MASW line, a series of 24 low frequency (4.5 Hz) geophones were laid out at 2 metre intervals. Both active and passive readings were recorded along the MASW line. For the active investigation, a seismic drop of 34 kg and a 9.9 kg sledge hammer were used as seismic sources. Active seismic records were collected with seismic sources located 5, 10, 15, and 20 metres from and collinear to the geophone array. An example of active seismic records collected is shown in Figure 2 below.

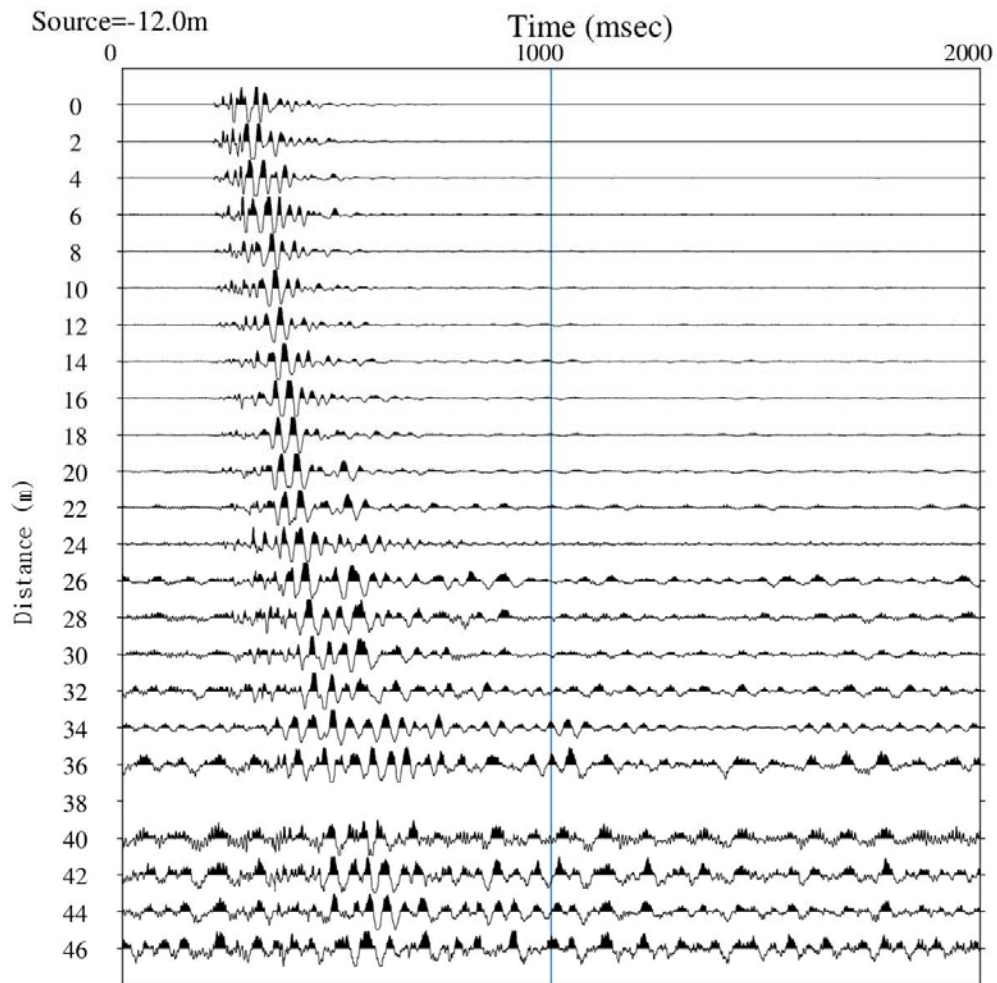

Figure 2: Typical seismic record collected along MASW Line 1

Data Processing

Processing of the MASW test results consisted of the following main steps:

- 1) Transformation of the time domain data into the frequency domain using a Fast-Fourier Transform (FFT) for each source location;
- 2) Calculation of the phase for each frequency component;
- 3) Linear regression to calculate phase velocity for each frequency component;
- 4) Filtering of the calculated phase velocities based on the Pearson correlation coefficient (r^2) between the data and the linear regression best fit line used to calculate phase velocity;
- 5) Generation of the dispersion curve by combining calculated phase velocities for each shot location of a single MASW test; and,
- 6) Generation of the stiffness profile, through forward iterative modelling and matching of model data to the field collected dispersion curve.

Processing of the MASW data was completed using the SeisImager/SW software package (Geometrics Inc.). The calculated phase velocities for a seismic shot point were combined and the dispersion curve generated by choosing the minimum phase velocity calculated for each frequency component as shown on Figure 3 and 4. Shear wave velocity profiles were generated through inverse modelling to best fit the calculated dispersion curves. The active survey provided a dispersion curve with a suitable frequency range (14 -33 Hz). The minimum measured surface wave frequency with sufficient signal-to-noise ratio to accurately measure phase velocity was approximately 14 Hz.

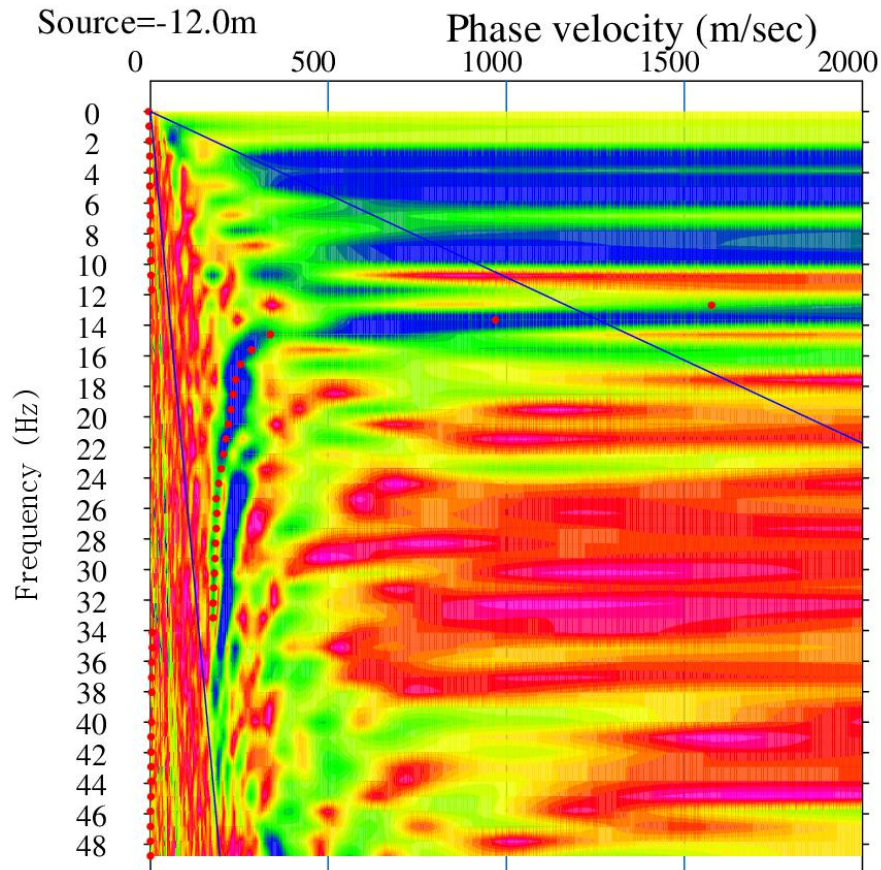

Figure 3: Active MASW Dispersion Curve Picks (red dots) along MASW Line 1

Results

The MASW test results are presented in Figure 4, which presents the calculated shear wave velocity profile derived from the field testing. The results along MASW Line 1 have been calculated using a weight-drop located at 15 m from the last geophone. The field collected dispersion curves are compared with the model generated dispersion curves on Figure 5. There is a satisfactory correlation between the field collected and model calculated dispersion curves, with a root mean squared error of less than 11%.

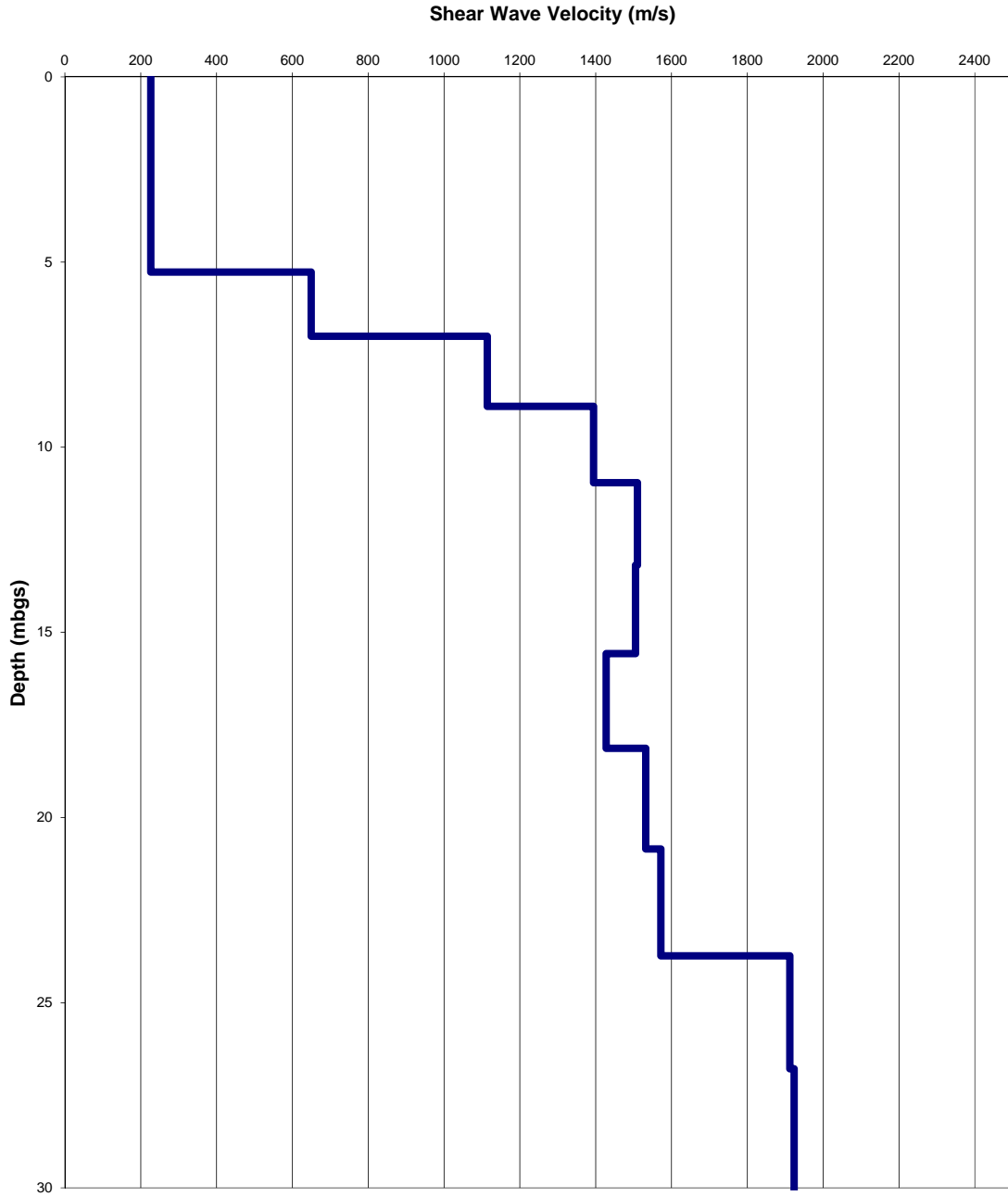

Figure 4: MASW Modelled Shear-Wave Velocity Depth profile along MASW Line 1

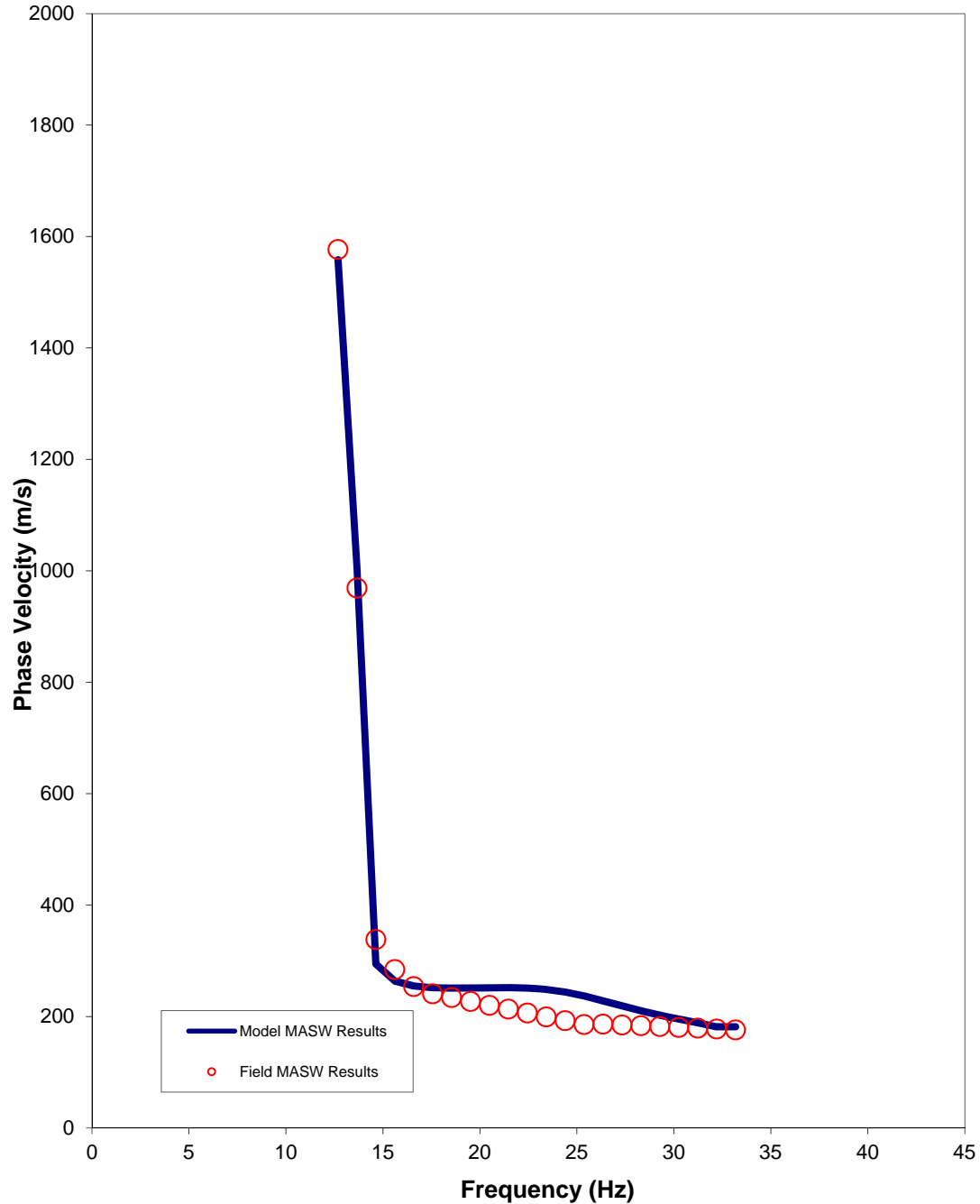

Figure 5: Comparison of Field (red dots) vs. Modelled Data (blue line) along MASW Line 1

To calculate the average shear-wave velocity as required by the Canadian Highway Bridge Design Code (CHBDC, 2014), the results were modelled to 30 metres below ground surface. The average shear-wave velocity along MASW Line 1 was found to be 734 m/s (Table 1).

The Canadian Highway Bridge Design Code (CHBDC, 2014) requires special site-specific evaluation if certain soil types are encountered on the site, so the site classification stated here should be reviewed, and modified if necessary, according to borehole stratigraphy, standard penetration resistance results, and undrained shear strength measurements, if available for this site.

Table 1: Shear-Wave Velocity Profile along MASW Line 1

Model Layer (mbgs)		Layer Thickness (m)	Shear Wave Velocity (m/s)	Shear Wave Travel Time Through Layer (s)
Top	Bottom			
0.00	1.07	1.07	226	0.004732
1.07	2.31	1.24	226	0.005460
2.31	3.71	1.40	226	0.006188
3.71	5.27	1.57	226	0.006916
5.27	7.01	1.73	650	0.002664
7.01	8.90	1.90	1114	0.001701
8.90	10.96	2.06	1395	0.001478
10.96	13.19	2.23	1510	0.001473
13.19	15.58	2.39	1505	0.001588
15.58	18.13	2.55	1428	0.001789
18.13	20.85	2.72	1532	0.001775
20.85	23.74	2.88	1572	0.001835
23.74	26.79	3.05	1912	0.001595
26.79	30.00	3.21	1924	0.001671
Vs Average to 30 mbgs (m/s)				734

Limitations

This technical memorandum, which specifically includes all tables, figures and attachments, is based on data and information collected by Golder Associates Ltd. and is based solely on the conditions of the properties at the time of the work, supplemented by historical information and data obtained by Golder Associates Ltd. as described in this memo.

Golder Associates Ltd. has relied in good faith on all information provided and does not accept responsibility for any deficiency, misstatements, or inaccuracies contained in the reports as a result of omissions, misinterpretation, or fraudulent acts of the persons contacted or errors or omissions in the reviewed documentation.

The services performed, as described in this memo, were conducted in a manner consistent with that level of care and skill normally exercised by other members of the engineering and science professions currently practicing under similar conditions, subject to the time limits and financial and physical constraints applicable to the services.

Any use which a third party makes of this memo, or any reliance on, or decisions to be made based on it, are the responsibilities of such third parties. Golder Associates Ltd. accepts no responsibility for damages, if any, suffered by any third party as a result of decisions made or actions based on this memo.

The findings and conclusions of this memo are valid only as of the date of this memo. If new information is discovered in future work, including excavations, borings, or other studies, Golder Associates Ltd. should be requested to re-evaluate the conclusions of this memo, and to provide amendments as required.

Closure

We trust that this technical memorandum meets your needs at the present time. If you have any questions or require clarification, please contact the undersigned at your convenience.

GOLDER ASSOCIATES LTD.

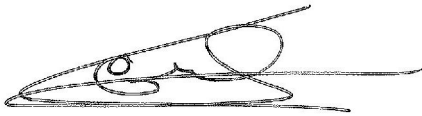

Stephane Sol, Ph.D, P. Geo.
Senior Geophysicist



Christopher Phillips, M. Sc., P. Geo.
Senior Geophysicist, Principal

SS/CRP/mvrd

n:\active\2016\3 proj\1655214 mto 4016-e-0001hwy 417 ottawa\foundations\3 - field work\geophysics\1655214_1500 mto\preston\report\1655214_1500 masw tech memo preston2017_8dec2017.docx

APPENDIX F

Site Photographs



**Photograph 1: Looking north along Booth Street towards the Highway 417 Overpass at Booth Street;
2019-03-13**



**Photograph 2: Looking south along Booth Street towards the Highway 417 Overpass at Booth Street;
2019-03-13**



Photograph 3: Looking southeast towards the northeast embankment; 2019-03-13



Photograph 4: Looking southwest towards the northwest embankment; 2019-03-13



Photograph 5: Looking northeast towards the southeast embankment; 2019-03-13



Photograph 6: Looking northwest towards the southwest embankment; 2019-03-13



golder.com